

Il grano consente di pre-posizionare l'incontro e di regolarne la posizione.
The grub screw allows pre-positioning of the striker and adjusting its position.
Der Gewindestift gestattet die Vorpositionierung der Schließplatte und die Einstellung ihrer Position.
El prisionero permite pre-posicionar y regular la posición de la platina.
La vis sans tête permet de pré-positionner la gâche et d'en régler la position.

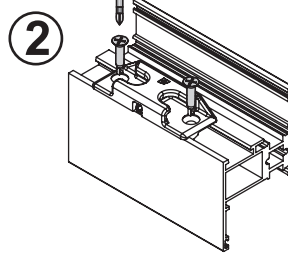
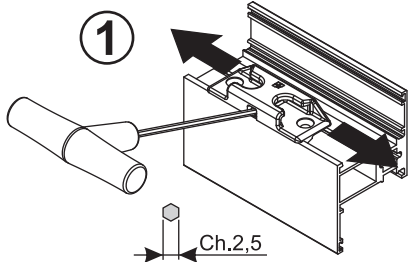

Una volta certi della posizione dell'incontro fissarlo con le due viti in dotazione.
After establishing the position of the striker, secure it with the two screws supplied.
Nach der Festlegung der Position der Schließplatte dieselbe mit den beiden mitgelieferten Schrauben befestigen.
Una vez ajustada la posición definitiva de la platina, fijarla con los dos tornillos en dotación.
Après avoir déterminé la position de la gâche, la fixer avec les deux vis fournis.

ANTA
Wing - Fensterflügel - Hoja - Vantail

H ≥ 660 L ≥ 220 Hc ≥ 330	H ≥ 660 L ≥ 220 Hc ≥ 330

ANTA(con microventilazione)
Wing(with microventilation) - Fensterflügel(mit Mikrobelflüftung)
Hoja(con microventilación) - Vantail(avec microventilation)

	02229 		02229
H ≥ 750 L ≥ 220 Hc ≥ 330		H ≥ 750 L ≥ 220 Hc ≥ 330	

ANTA RIBALTA
Tilt-and-turn - Drehkipplügel
Hoja abatible - Oscillo-battant

H ≥ 660 L ≥ 500 Hc ≥ 330	H ≥ 660 L ≥ 500 Hc ≥ 330

ANTA RIBALTA(con microventilazione)
Tilt-and-turn(with microventilation) - Drehkipplügel(mit Mikrobelflüftung)
Hoja abatible(con microventilación) - Oscillo-battant(avec microventilation)

	02234 		02234
H ≥ 840 L ≥ 500 Hc ≥ 330		H ≥ 840 L ≥ 500 Hc ≥ 330	

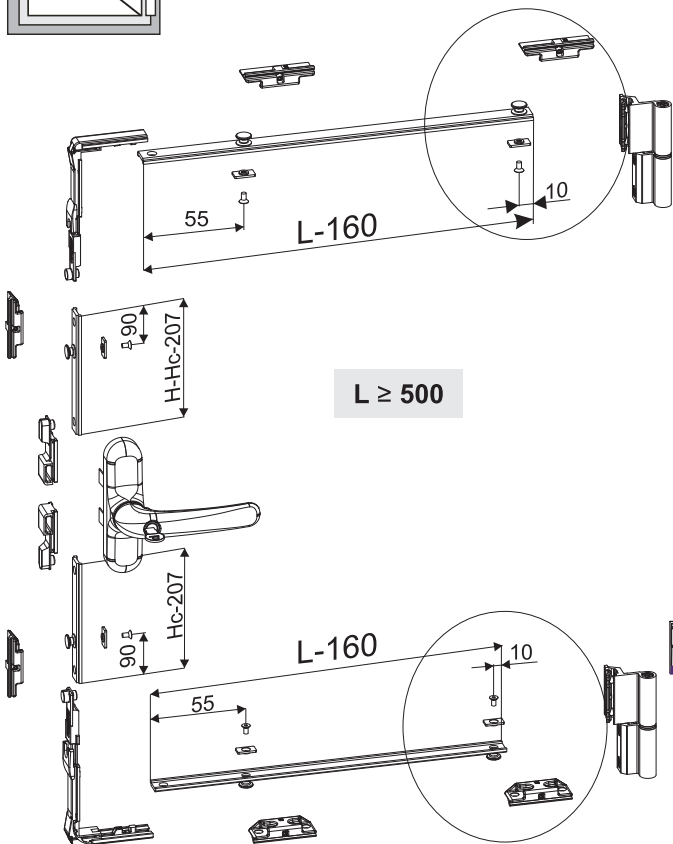
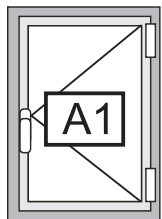

L ≥ 500

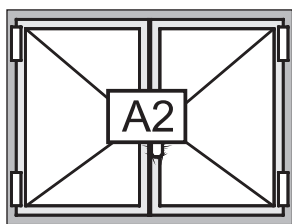

L ≥ 500

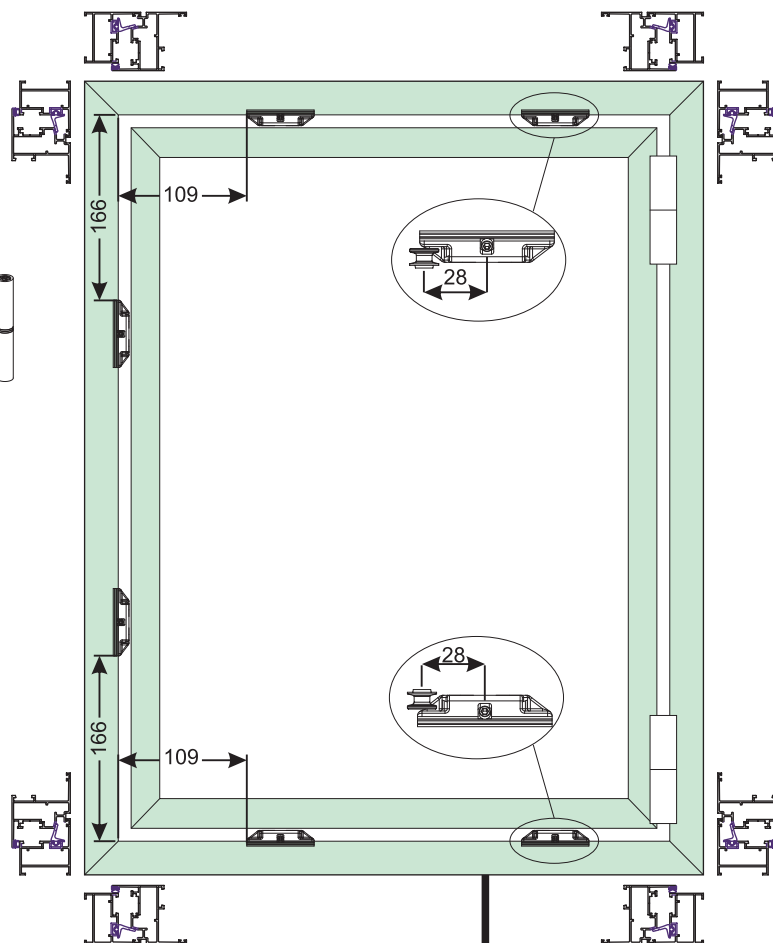
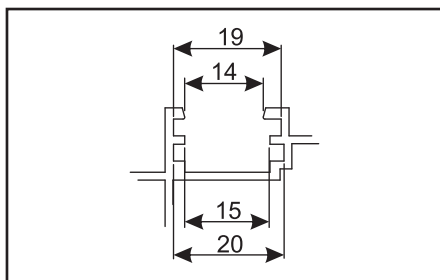

A1

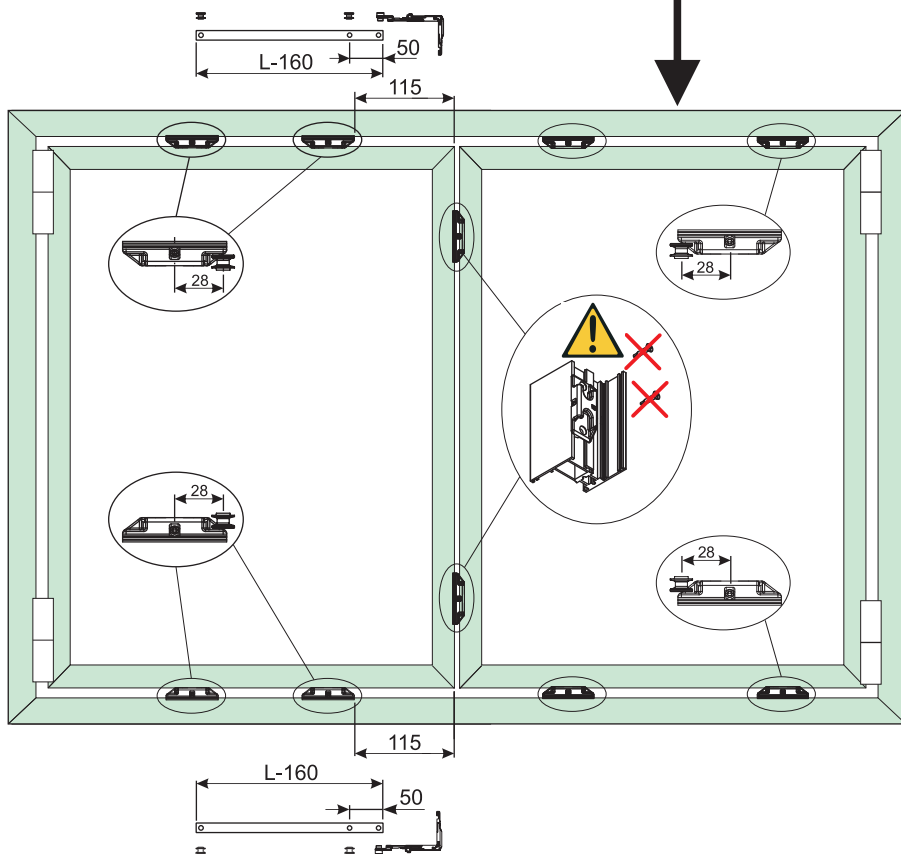

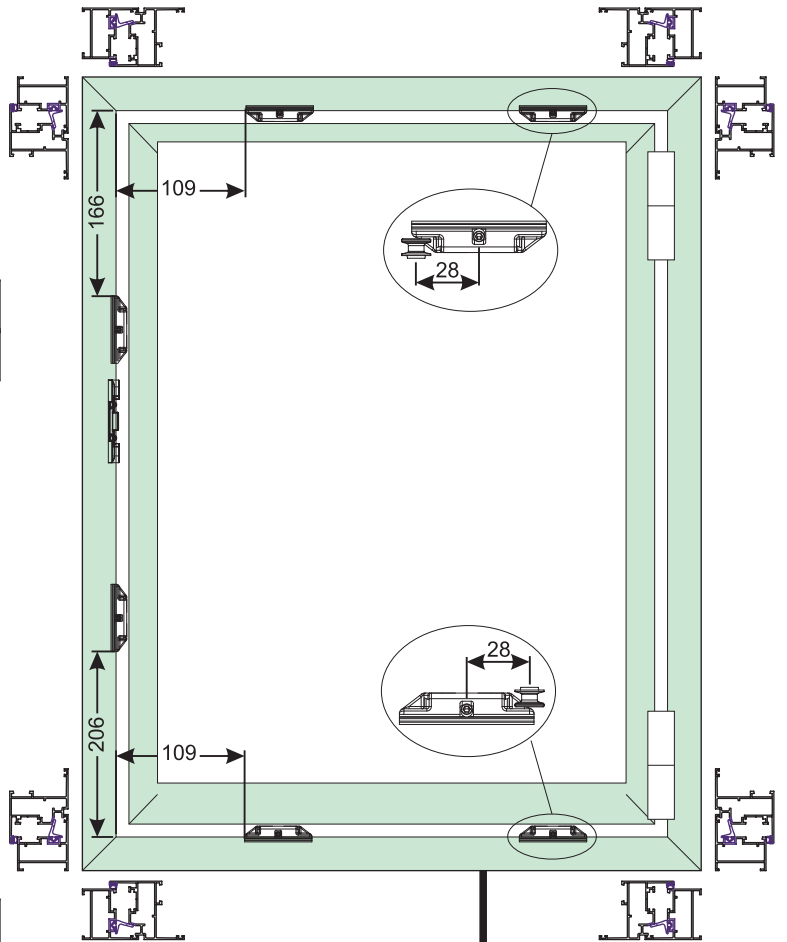
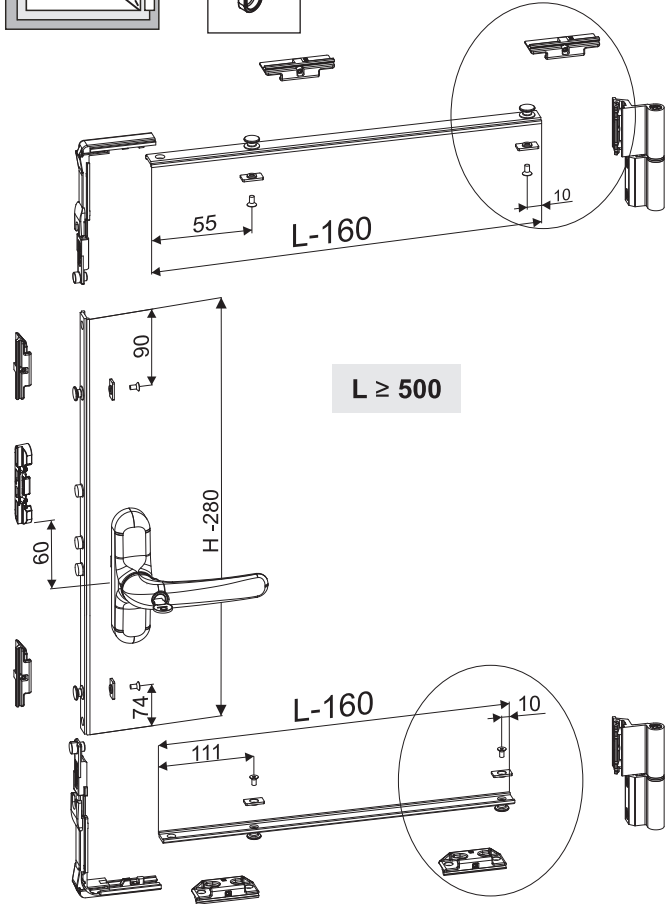
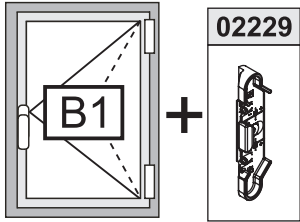

B1

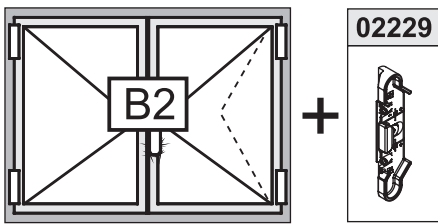

L ≥ 500

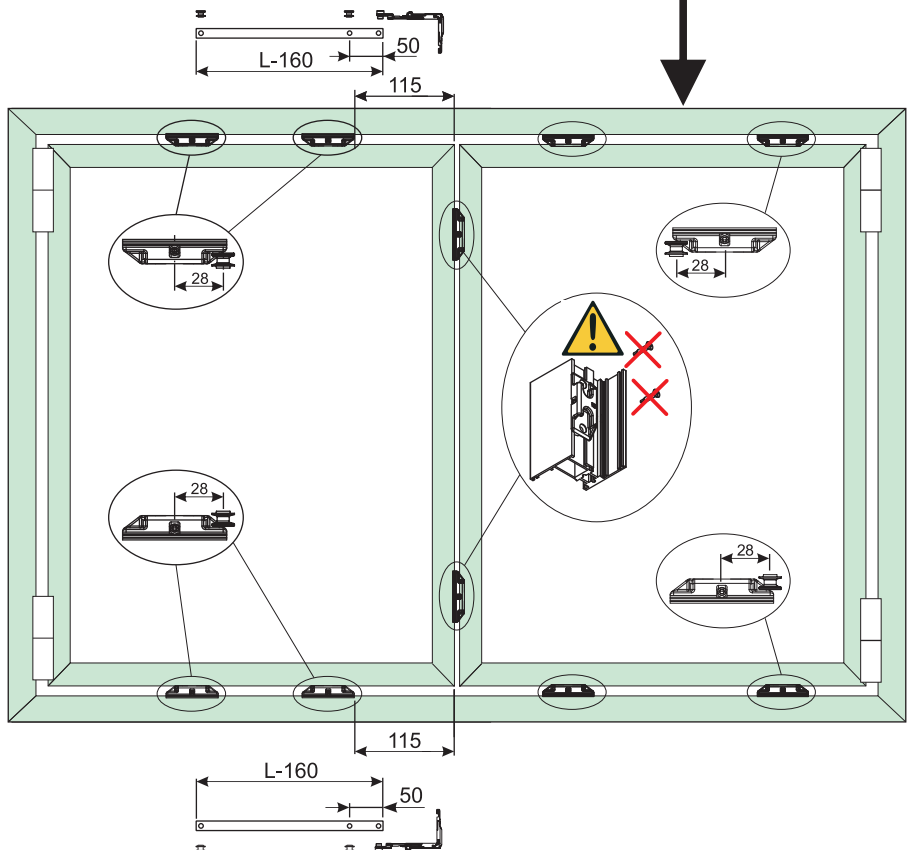
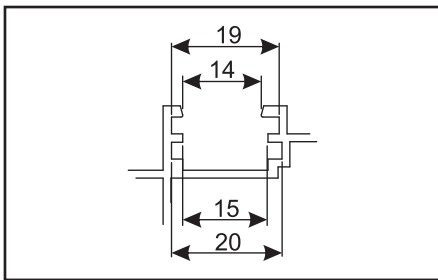

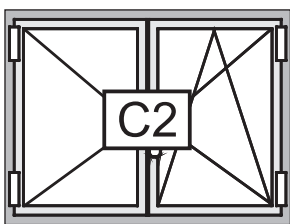
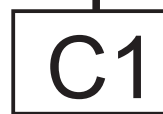
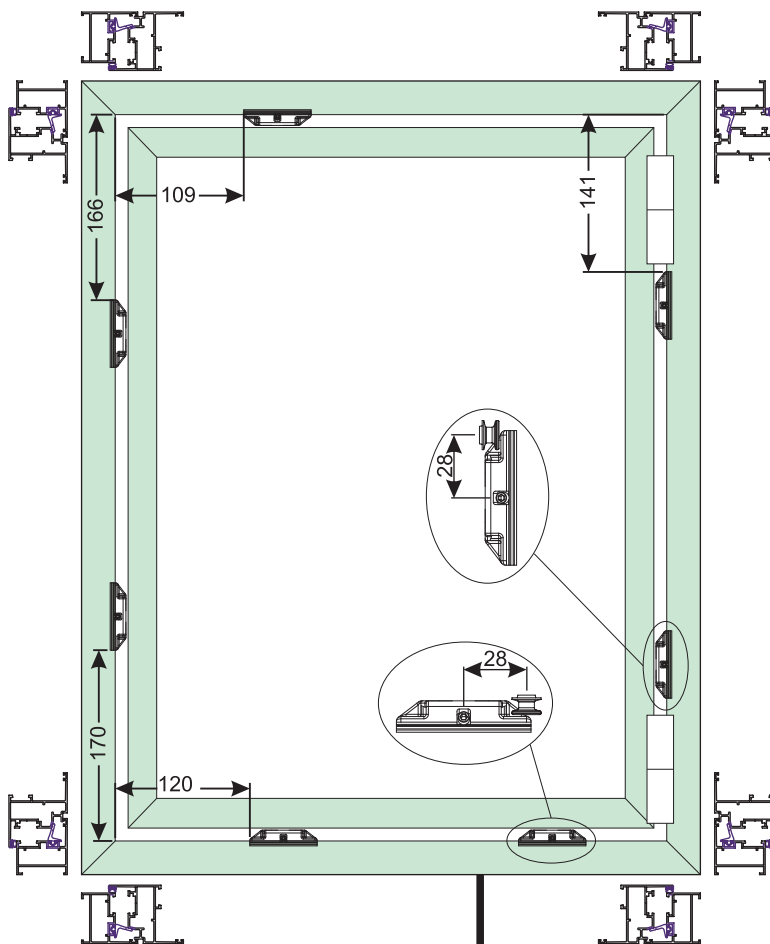
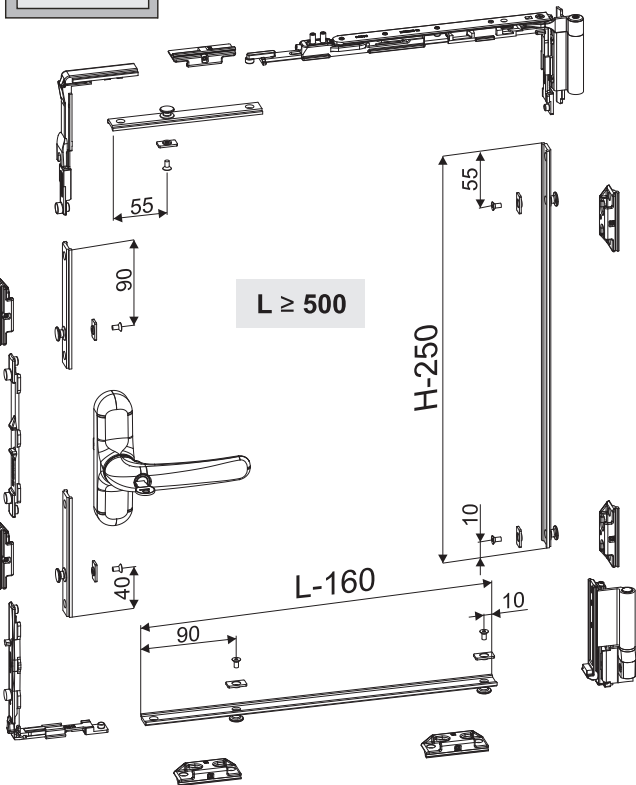
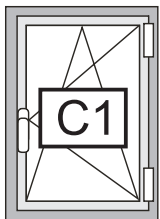

$L \geq 500$

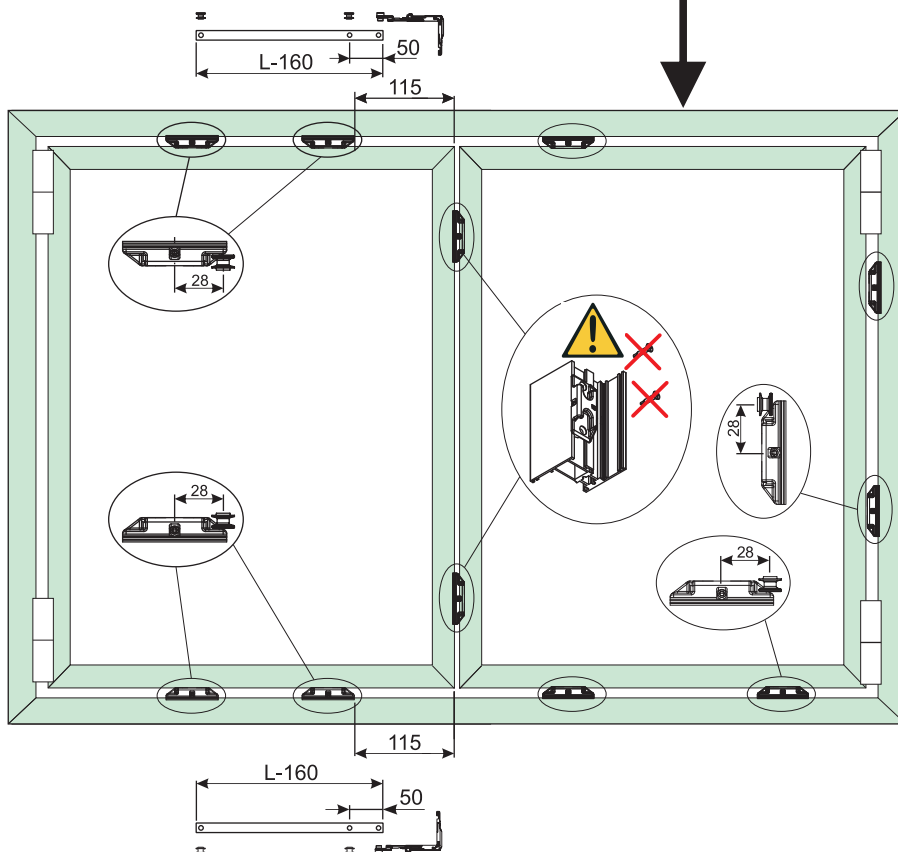
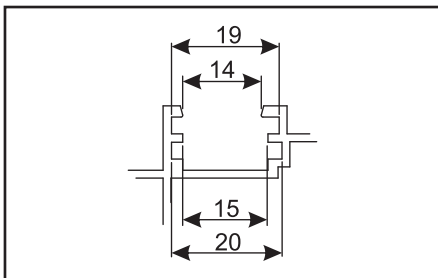

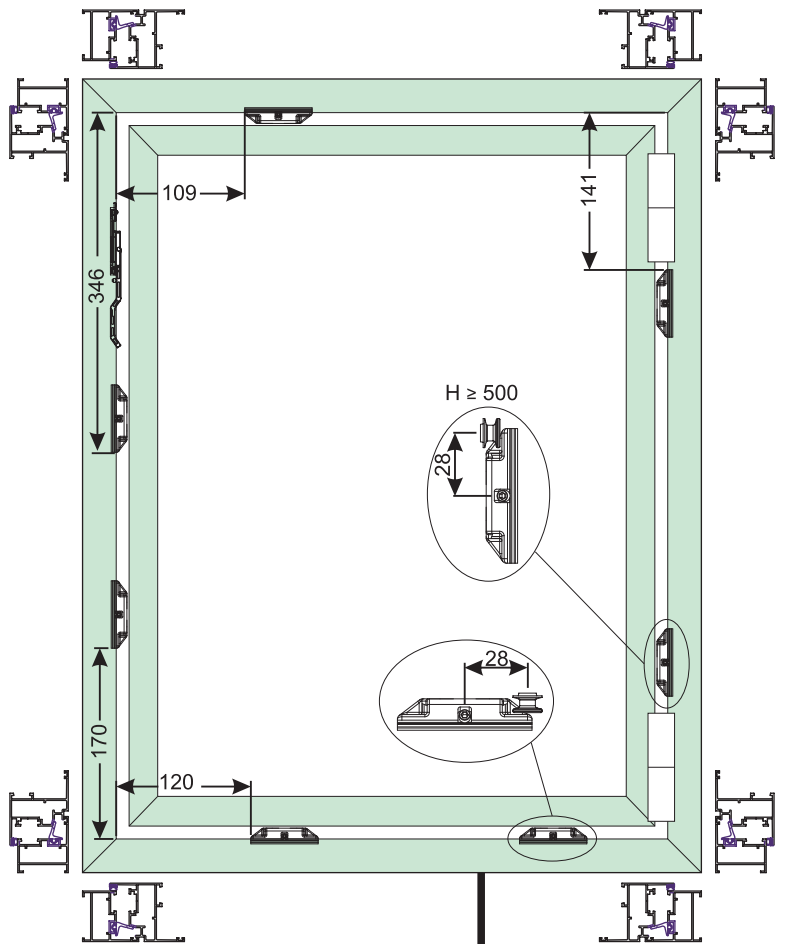
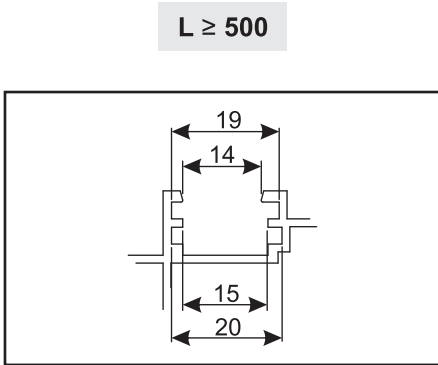
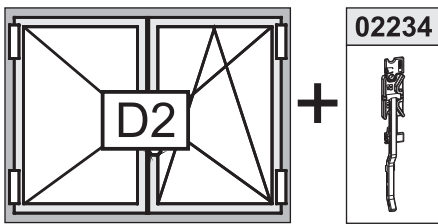
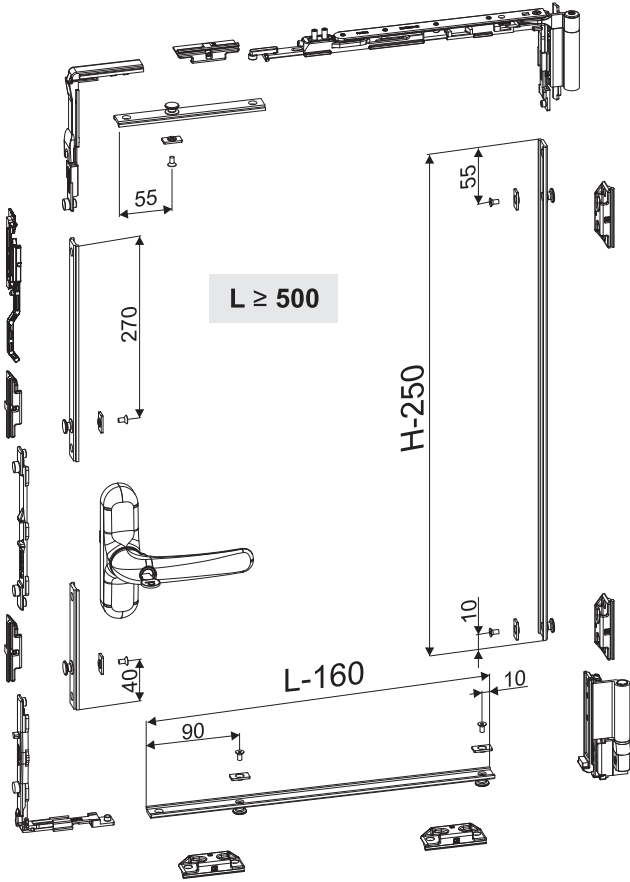
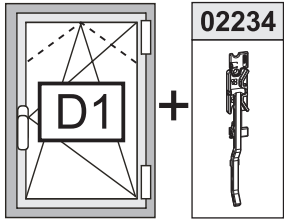

D1

