

ATTENZIONE: il foro di preparazione per la vite di fissaggio deve avere diametro di 3,25 mm.

WARNING: the hole for the fixing screw must have diameter of 3,25 mm.

**VITE CONSIGLIATA:
RECOMMENDED SCREWS:**

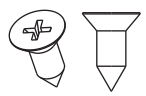

Vite autofilettante Ø4,2
Self-tapping screw Ø4,2

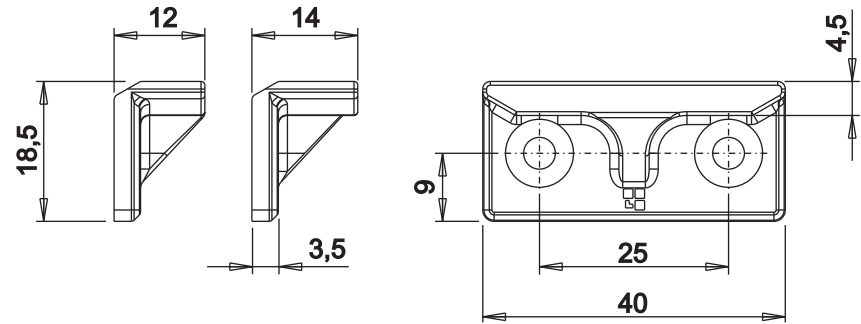
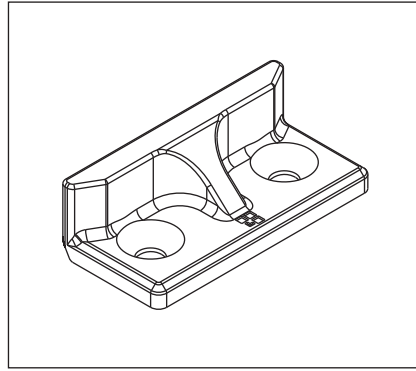
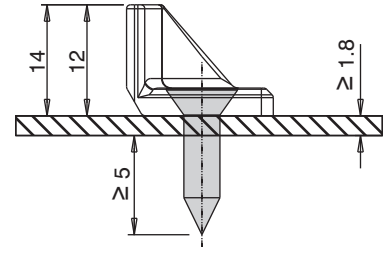

ATTENZIONE: il foro di preparazione per la vite di fissaggio deve avere diametro di 3,25 mm.

WARNING: the hole for the fixing screw must have diameter of 3,25 mm.

**VITE CONSIGLIATA:
RECOMMENDED SCREWS:**

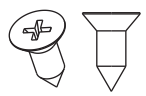

Vite autofilettante Ø4,2
Self-tapping screw Ø4,2

