



Dimensioni e Portate realizzabili - Dimensiones y Capacidades admitidas
Διαστάσεις και Βάρη πραγματοποιήσιμα - Possible Dimensions and Capacities
Zulässige Abmessungen und Gewichte - Dimensions et charges possibles

ATTENZIONE: Le portate e il perfetto funzionamento dell'accessorio vengono garantiti solo se non vi sono impedimenti nella movimentazione dell'anta che forzino in modo anomalo le cerniere (ad esempio spillature, tappi od altri elementi di arresto). In questo caso è obbligatorio l'utilizzo di un braccio limitatore FRIZ.

ΠΡΟΣΟΧΗ: Εγγυόμαστε για το βάρος του κουφώματος όταν δεν υπάρχουν εμπόδια κατά το άνοιγμα που εμποδίζουν τη σωστή λειτουργία των μεντεσέδων. Σ' αυτή την περίπτωση είναι υποχρεωτική η χρήση του κουμπάσου φρένο.

ACHTUNG: Die Tragfähigkeit und einwandfreie Funktion des Beschlages sind nur dann gewährleistet, wenn die Flügelbewegung ungehindert, d.h. ohne übermäßige Beanspruchung der Bänder, erfolgt (z.B. durch Absätze, Kappen oder andere Hindernisse). In diesem Fall muss die Begrenzungsschere FRIZ verwendet werden.

ATENCIÓN: Las capacidades y el perfecto funcionamiento del accesorio están garantizados si no hay obstáculos en el movimiento de la hoja que fuercen de modo anómalo las bisagras (por ejemplo elementos de apoyo, capuchones u otros elementos de parada). En este caso es obligatorio utilizar el brazo limitador FRIZ.

CAUTION: The capacities and correct functioning of the accessory are only guaranteed if there are no obstacles preventing movement of the wing which force the hinges excessively (such as protrusions, stoppers or other stop elements). In such cases, you MUST use a FRIZ limiter arm.

ATTENTION : Les charges et le fonctionnement sont garantis si rien n'entrave le mouvement du vantail en soumettant les charnières à un effort anormal (par exemple, saillies, tampons ou autres dispositifs d'arrêt). Dans ce cas, il est obligatoire d'utiliser le bras limiteur FRIZ.

Spessore massimo del vetro impiegabile (senza camera d'aria) (mm) - Espesor máximo del cristal que se puede utilizar (sin cámara de aire) (mm) - Μέγιστη απόσταση τζαμιών (χωρίς το κενό) (mm) - Maximum possible thickness of glass (without air space) (mm) - Max. zulässige Glasstärke (ohne Luftzwischenraum) (mm) - Épaisseur maximale utilisable pour le vitrage (sans lame d'air) (mm)

| | | | | | | | | | |
|------|----|----|----|----|----|----|----|----|----|
| 2500 | 25 | 21 | 18 | 16 | 14 | 13 | 11 | 10 | 10 |
| 2400 | 26 | 22 | 19 | 16 | 15 | 13 | 12 | 11 | 10 |
| 2300 | 27 | 23 | 19 | 17 | 15 | 14 | 12 | 11 | 10 |
| 2200 | 27 | 23 | 19 | 17 | 15 | 14 | 12 | 11 | 10 |
| 2100 | 29 | 24 | 20 | 18 | 16 | 14 | 13 | 12 | 11 |
| 2000 | 30 | 25 | 21 | 19 | 17 | 15 | 14 | 12 | 11 |
| 1900 | 31 | 26 | 22 | 20 | 17 | 16 | 14 | 13 | 12 |
| 1800 | 33 | 28 | 24 | 21 | 18 | 17 | 15 | 14 | 13 |
| 1700 | 35 | 29 | 25 | 22 | 19 | 17 | 16 | 15 | 13 |
| 1600 | 37 | 31 | 26 | 23 | 21 | 18 | 17 | 15 | 14 |
| 1500 | 39 | 33 | 28 | 25 | 22 | 20 | 18 | 16 | 15 |
| 1400 | 42 | 35 | 30 | 26 | 23 | 21 | 19 | 17 | 16 |
| 1300 | 45 | 37 | 32 | 28 | 25 | 22 | 20 | 19 | 17 |
| 1200 | 48 | 40 | 34 | 30 | 27 | 24 | 22 | 20 | 17 |
| 1100 | 50 | 44 | 37 | 33 | 29 | 26 | 24 | 20 | 17 |
| 1000 | 50 | 48 | 41 | 36 | 32 | 29 | 24 | 20 | 17 |
| 900 | 50 | 50 | 45 | 39 | 35 | 29 | 24 | | |
| 800 | 50 | 50 | 50 | 44 | 35 | 29 | | | |
| 700 | 50 | 50 | 50 | 45 | 35 | | | | |
| 600 | 50 | 50 | 50 | 45 | | | | | |

Non realizzabile
 No puede realizarse
 Μη πραγματοποιήσιμα
 Not possible
 Nicht möglich
 Irréalizable

Larghezza anta (mm) - Anchura hoja (mm) - Πλάτος Φύλλου (mm) - Wing width (mm) - Flügelbreite (mm) - Largeur vantail (mm)

Peso massimo dell'anta (alluminio e vetro) - Peso máximo de la hoja (aluminio y cristal) - Μέγιστο βάρος Φύλλου (Αλουμίνιο & Τζάμι) - Maximum wing weight (aluminium and glass) - Max. Flügengewicht (Aluminium und Glas) - Poids maximum du vantail (aluminium et vitrage)

| | | | | | | | | | |
|------|----|----|----|----|----|----|----|----|----|
| 2500 | 80 | 80 | 80 | 80 | 80 | 80 | 80 | 80 | 80 |
| 2400 | 80 | 80 | 80 | 80 | 80 | 80 | 80 | 80 | 80 |
| 2300 | 80 | 80 | 80 | 80 | 80 | 80 | 80 | 80 | 80 |
| 2200 | 80 | 80 | 80 | 80 | 80 | 80 | 80 | 80 | 80 |
| 2100 | 80 | 80 | 80 | 80 | 80 | 80 | 80 | 80 | 80 |
| 2000 | 80 | 80 | 80 | 80 | 80 | 80 | 80 | 80 | 80 |
| 1900 | 80 | 80 | 80 | 80 | 80 | 80 | 80 | 80 | 80 |
| 1800 | 80 | 80 | 80 | 80 | 80 | 80 | 80 | 80 | 80 |
| 1700 | 80 | 80 | 80 | 80 | 80 | 80 | 80 | 80 | 80 |
| 1600 | 80 | 80 | 80 | 80 | 80 | 80 | 80 | 80 | 80 |
| 1500 | 80 | 80 | 80 | 80 | 80 | 80 | 80 | 80 | 80 |
| 1400 | 80 | 80 | 80 | 80 | 80 | 80 | 80 | 80 | 80 |
| 1300 | 80 | 80 | 80 | 80 | 80 | 80 | 80 | 80 | 78 |
| 1200 | 80 | 80 | 80 | 80 | 80 | 80 | 79 | 73 | 67 |
| 1100 | 80 | 80 | 80 | 80 | 80 | 80 | 73 | 67 | |
| 1000 | 80 | 80 | 80 | 80 | 80 | 73 | 66 | | |
| 900 | 80 | 80 | 80 | 80 | 73 | 66 | | | |
| 800 | 80 | 80 | 80 | 73 | 65 | | | | |
| 700 | 80 | 80 | 73 | 64 | | | | | |
| 600 | 80 | 80 | 73 | 64 | | | | | |

Non realizzabile
 No puede realizarse
 Μη πραγματοποιήσιμα
 Not possible
 Nicht möglich
 Irréalizable

Larghezza anta (mm) - Anchura hoja (mm) - Πλάτος Φύλλου (mm) - Wing width (mm) - Flügelbreite (mm) - Largeur vantail (mm)

ANTA RIBALTA GIESSE - HOJA OSCILO BATIENTE GIESSE - ΜΗΧΑΝΙΣΜΟΣ ΑΝΑΚΛΙΣΗΣ GIESSE GIESSE TILT-AND-TURN - GIESSE DREHKIPPBESCHLAG - OSCILLO-BATTANT GIESSE

Lubrificare con prodotti a base di vaselina sia le guide che tutti i meccanismi prima del loro inserimento.

Impiegare astine di collegamento in poliammide GIESSE o in alternativa in alluminio con trattamento di ossidazione e non di verniciatura.

Eseguire sull'anta mobile le lavorazioni indicate su questo documento.

Si garantisce il funzionamento dell'accessorio descritto in queste istruzioni solo se l'infisso è stato installato a regola d'arte, quindi in squadra e senza impedimenti nell'apertura totale (a 180°) dell'anta. Qualora questo non sia possibile è d'obbligo l'utilizzo di elementi limitatori d'apertura quali il Braccio FRIZ GIESSE.

Λαβάνετε με προϊόντα που έχουν βάση τη βαζελίνη τους οδηγούς και όλους τους μηχανισμούς πριν την τοποθέτησή τους.

Κόψτε και τρυπήστε λαμάκια από πολυαμίδιο GIESSE ή εναλλακτικά λαμάκια αλουμινίου ανοδιωμένο και όχι βαμμένο ηλεκτροστατικά.

Συνεχίστε με το φύλλο όπως βλέπετε στις οδηγίες.

Εγγυόμαστε τη λειτουργία των εξαρτημάτων που περιγράφονται στις οδηγίες μόνο αν το κούφωμα είναι κατασκευασμένο με τις προδιαγραφές του κατασκευαστή και τοποθετημένο σωστά, και χωρίς να υπάρχουν εμπόδια κατά το άνοιγμά του στις 180°. Αν αυτό δεν είναι εφικτό υποχρεωτικά θα πρέπει να χρησιμοποιήσετε εξαρτήματα που σταματάνε το κούφωμα όπως το Φρένο-Stop της GIESSE.

Lubricar con productos a base de vaselina tanto las guías como todos los mecanismos antes de introducirlos.

Utilizar varillas de conexión de poliamida GIESSE o en alternativa de aluminio con tratamiento de oxidación y sin pintura.

Realizar en la hoja móvil las preparaciones indicadas en este documento.

Se garantiza el funcionamiento del accesorio descrito en estas instrucciones sólo si el bastidor se ha instalado correctamente, es decir, en escuadra y sin obstáculos en la apertura total (a 180°) de la hoja.

En caso de que esto no sea posible, es obligatorio utilizar elementos limitadores de la apertura, como el Brazo FRIZ GIESSE.

Use vaseline-based products to lubricate both the guides and all the mechanisms before inserting them.

Use GIESSE polyamide connecting rods or aluminium connecting rods which have been subject to oxidation treatment and not painted.

Carry out all the machining operations on the mobile wing indicated in this document. Correct functioning of the accessory described in these instructions is only guaranteed if the window has been installed correctly, that is, flush and without obstacles preventing total wing opening (at 180°).

If this is not possible, you MUST use opening limiter elements such as the GIESSE FRIZ arm.

Die Führungen und alle Getriebeteile vor dem Einbau mit Vaseline einfetten. Polyamid-Verbindungsstangen von GIESSE oder Verbindungsstangen aus eloxiertem und unlackiertem Aluminium verwenden.

Am Flügel die in dieser Anleitung angegebenen Bearbeitungen ausführen.

Die einwandfreie Funktion des in dieser Anleitung beschriebenen Beschlags ist nur dann gewährleistet, wenn das Fenster sachgerecht montiert wurde, d.h. lotrecht und ohne Hindernisse bei der vollständigen Öffnung (180°) des Flügels.

Sollte dies nicht möglich sein, müssen Öffnungsbegrenzer, wie beispielsweise die Schere FRIZ GIESSE eingesetzt werden.

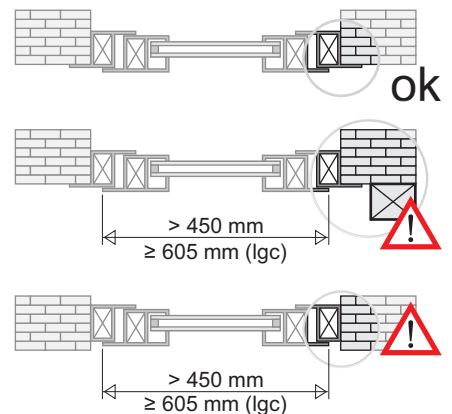

Avant tout montage, lubrifier les guides et tous les mécanismes avec des produits à base de vaseline.

Utiliser des triangles en polyamide GIESSE ou en aluminium ayant subi un traitement contre l'oxydation et non un vernissage.

Effectuer sur l'ouvrant les usinages indiqués dans le présent document.

Le bon fonctionnement de l'accessoire qui est décrit dans les présentes instructions est garanti uniquement si la fenêtre est montée dans les règles de l'art, c'est-à-dire à angle droit et sans que l'ouverture totale (à 180°) du vantail soit entravée.

Si cela est impossible, il est obligatoire d'utiliser des éléments limitant l'ouverture comme le bras FRIZ GIESSE.

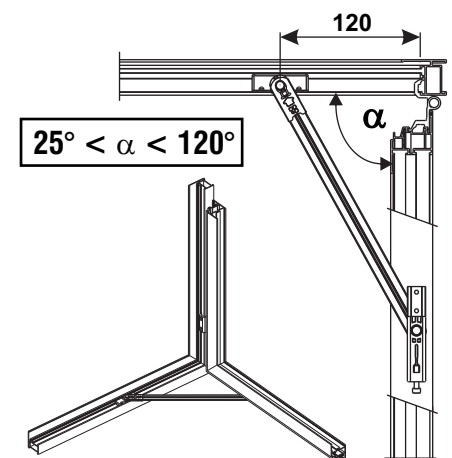

LAVORAZIONI PRELIMINARI SU ANTA MOBILE - OPERACIONES PRELIMINARES EN LA HOJA MÓVIL ΠΡΟΕΡΓΑΣΙΕΣ ΣΤΟ ΦΥΛΛΟ - PRELIMINARY MOBILE WING MACHINING OPERATIONS BEARBEITUNGEN AM FLÜGEL - USINAGES PRELIMINAIRES A PRATIQUER SUR L'OUVRANT

Detailed technical drawings of the window wing. The drawings show various views and dimensions:

- Top left: Detail of the wing edge with a dimension of $\geq 4,5$.
- Top middle: Detail of a hole with dimensions $10_{-0,5}$ and $\varnothing 8$.
- Bottom left: Overall view of the window frame with dimensions 107, 84, 8, and 11.
- Bottom middle: Detailed view of the wing with dimensions 104, 86, 9, 0,65, 0,55, 9, 7,2, and $\varnothing 5,5$.
- Bottom right: Detailed view of the wing with dimensions H_m , 21,5, 21,5, $\varnothing 10,5 / \varnothing 13$, $\varnothing 5,5 / \varnothing 10$, $\varnothing 5,5 / \varnothing 10$, H_m , 15 $\pm 0,2$, 11,1, and $A \pm 0,2$.

| X | A | B |
|--------------------|----|----|
| $X \leq 19$ | 15 | 60 |
| $19 < X \leq 22,5$ | 13 | 35 |
| $X > 22,5$ | - | - |

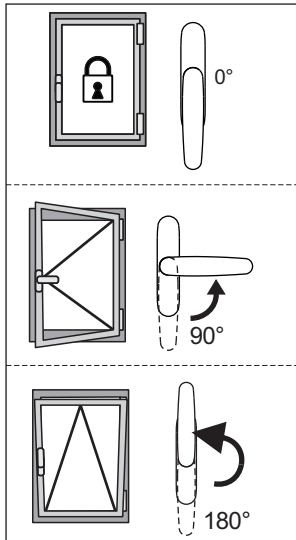
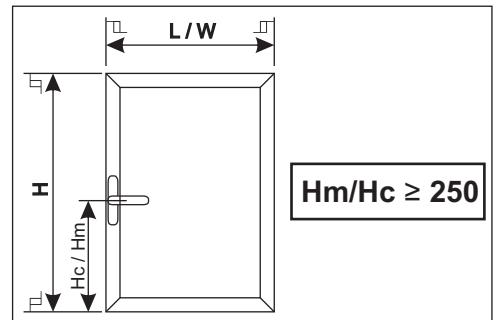
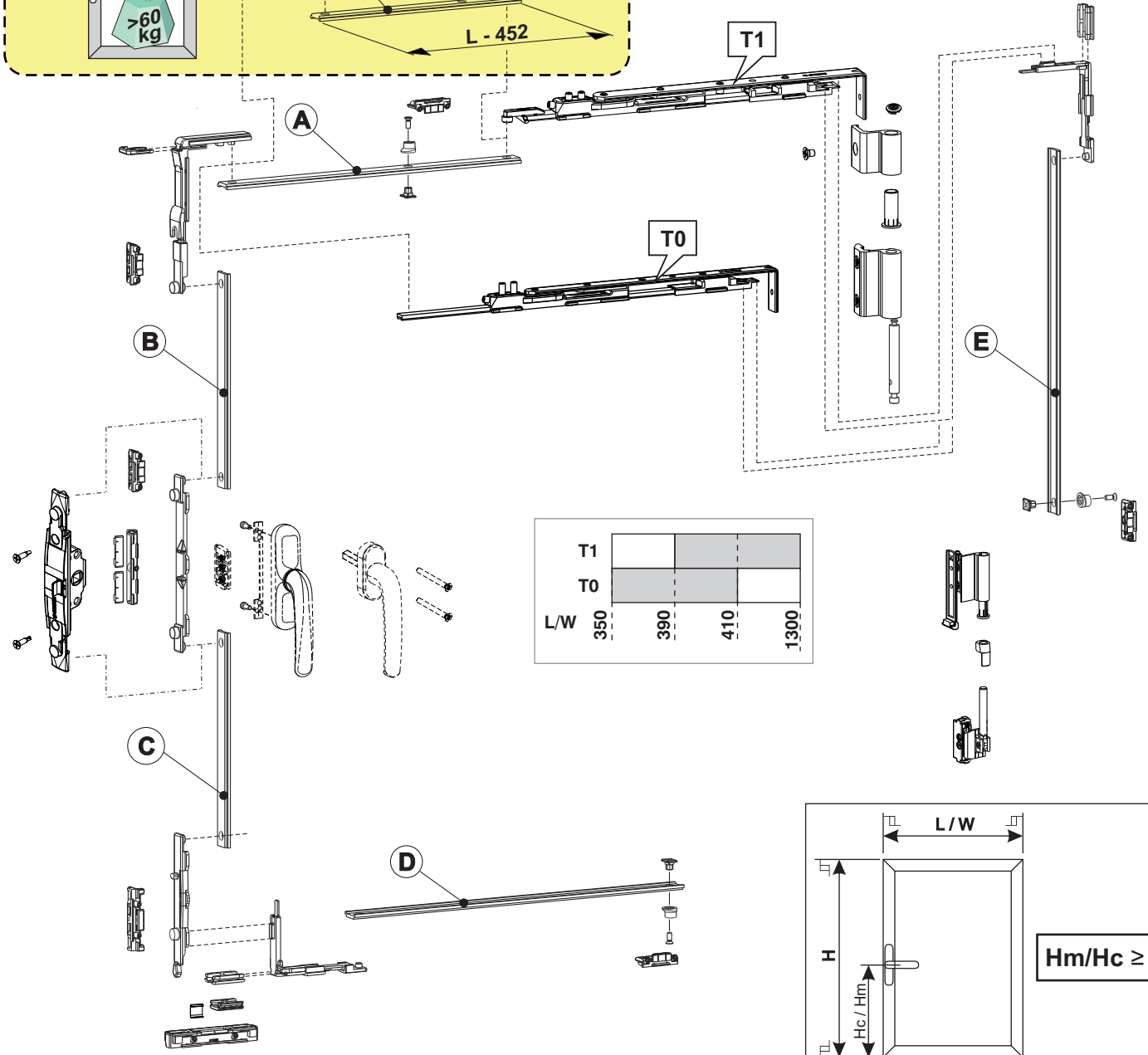
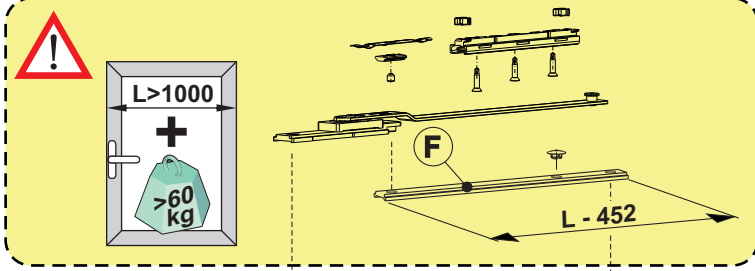

| | | | | | | | | | |
|------|-------|------------------------------------|-------|---|-------|--|------|----|------|
| 2500 | B E | B=H-Hc-207 C=Hc-207 E=H/2-69 | A E | A=L-355 B=H-Hc-207 C=Hc-207 E=H/2-69 | A E | A= L-355 B= H-Hc-207 C= Hc-207 D= L/2-69 E= H/2-69 | | | |
| | C | | C | | C | | | | |
| 1200 | B | B=H-Hc-207 C=Hc-207 | A | A=L-355 B=H-Hc-207 C=Hc-207 | D | A= L-355 B= H-Hc-207 C= H c-207 D= L/2-69 | | | |
| 600 | C | | C | | C | | | | |
| | 350 | T0 | 410 | 390 | T1 | 1000 | 1001 | T1 | 1300 |

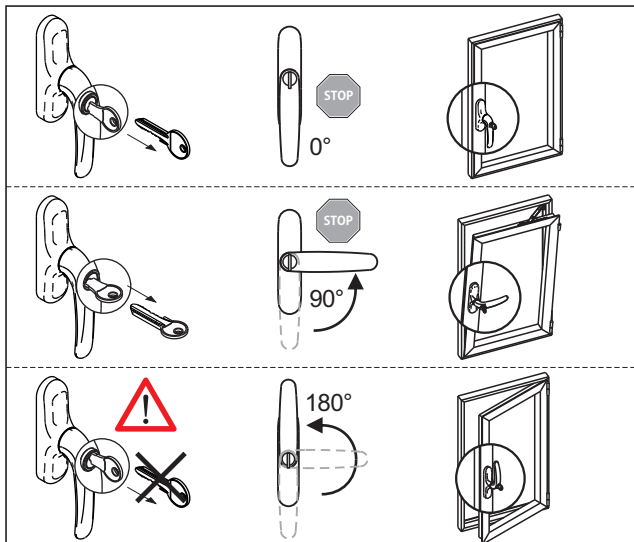
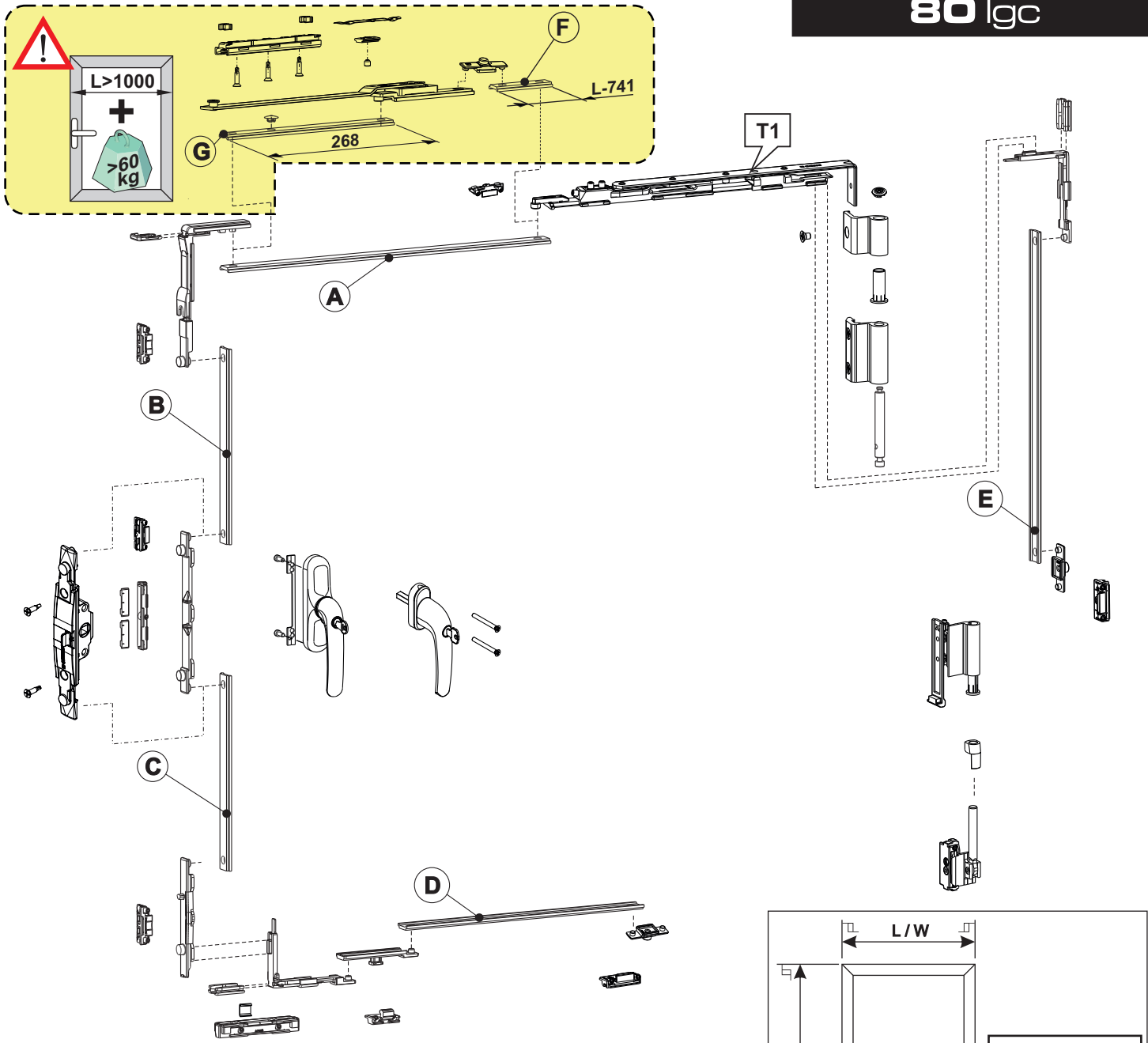

| | | | | | |
|------|------|---|---|--|--|
| 2500 | | <p>A= L-355 B= H-Hc-207 C= Hc-207 E= H/2-69</p> | | <p>A= L-355 B= H-Hc-207 C= Hc-207 D= L/2-139 E= H/2-69</p> | |
| | 1200 | | <p>A= L-355 B= H-Hc-207 C= Hc-207</p> | | <p>A= L-355 B= H-Hc-207 C= Hc-207 D= L/2-139</p> |
| 600 | | <p>A= L-355 B= H-Hc-207 C= Hc-207</p> | | <p>A= L-355 B= H-Hc-207 C= Hc-207 D= L/2-139</p> | |
| | 390 | T1 | 1000 | T1 | 1300 |

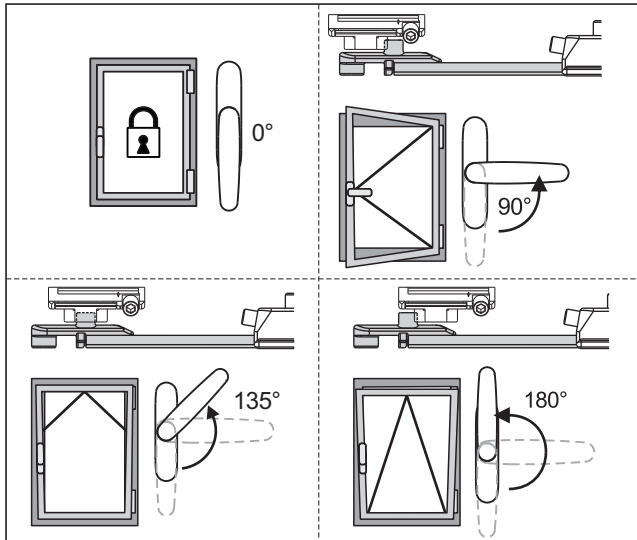
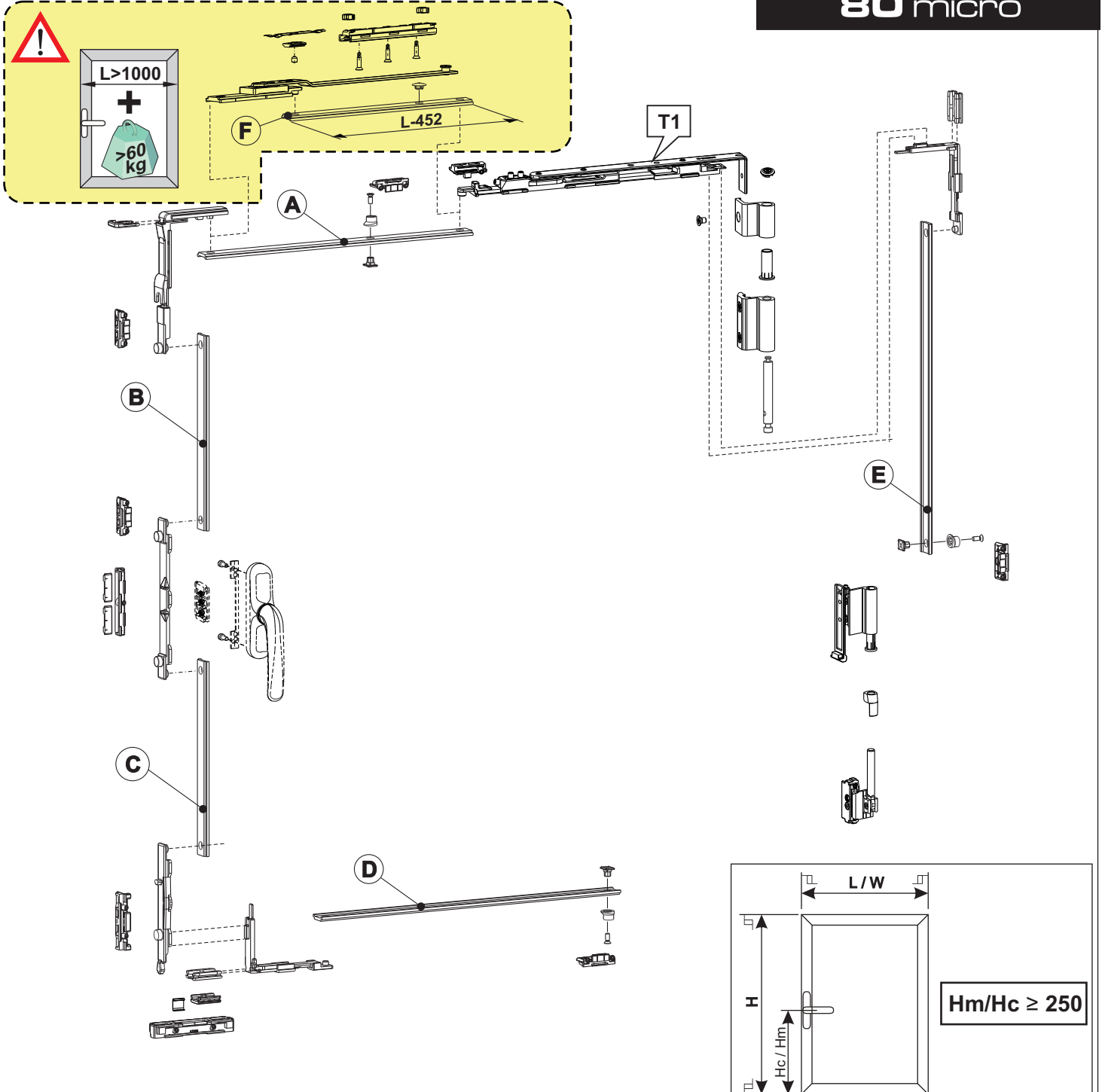

| | | | | |
|------|-----|---|------|---|
| 2500 | A | A = L-355 B = H-Hc-207 C = Hc-207 E = H/2-69 | A | A = L-355 B = H-Hc-207 C = Hc-207 D = L/2-69 E = H/2-69 |
| | B | | C | |
| 1200 | A | A = L-355 B = H-Hc-207 C = Hc-207 | A | A = L-355 B = H-Hc-207 C = H c-207 D = L/2-69 |
| 600 | B | | C | |
| | 410 | T1 | 1000 | T1 1300 |

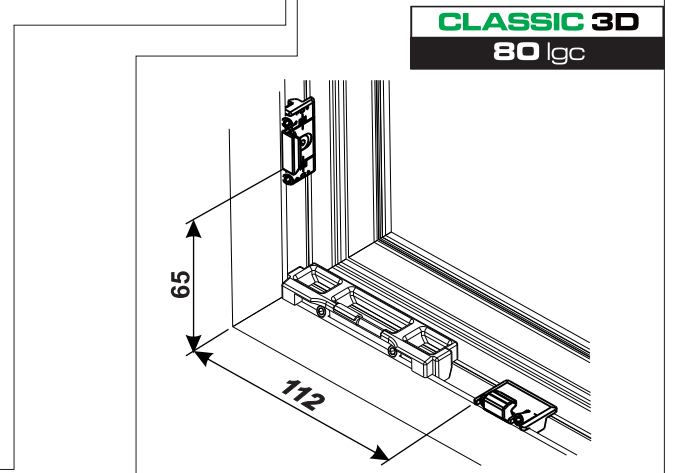
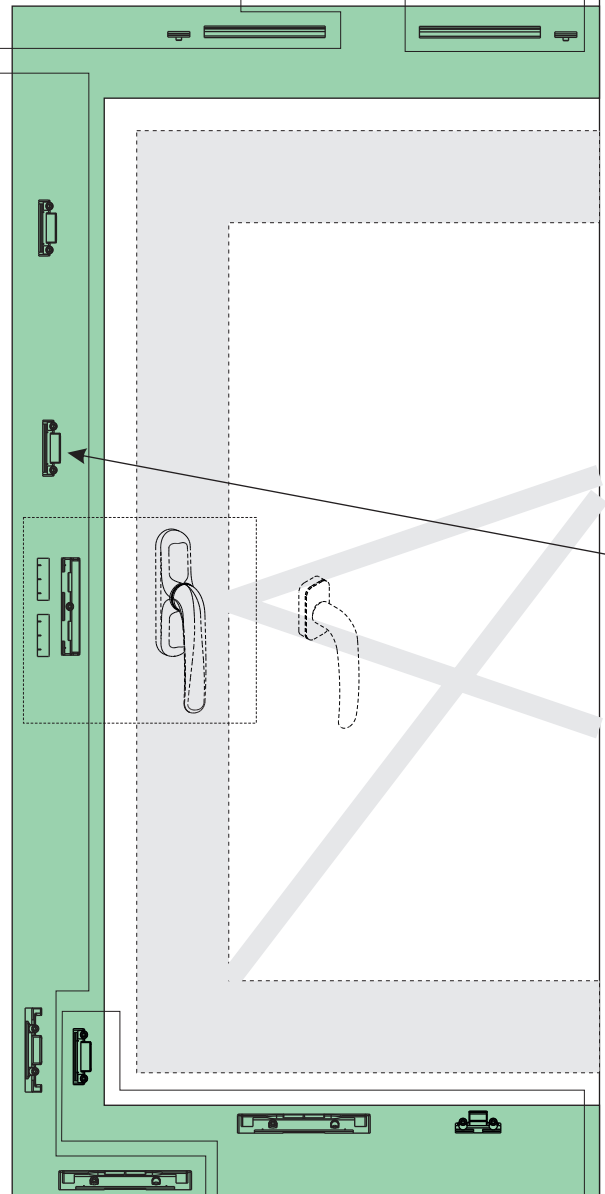
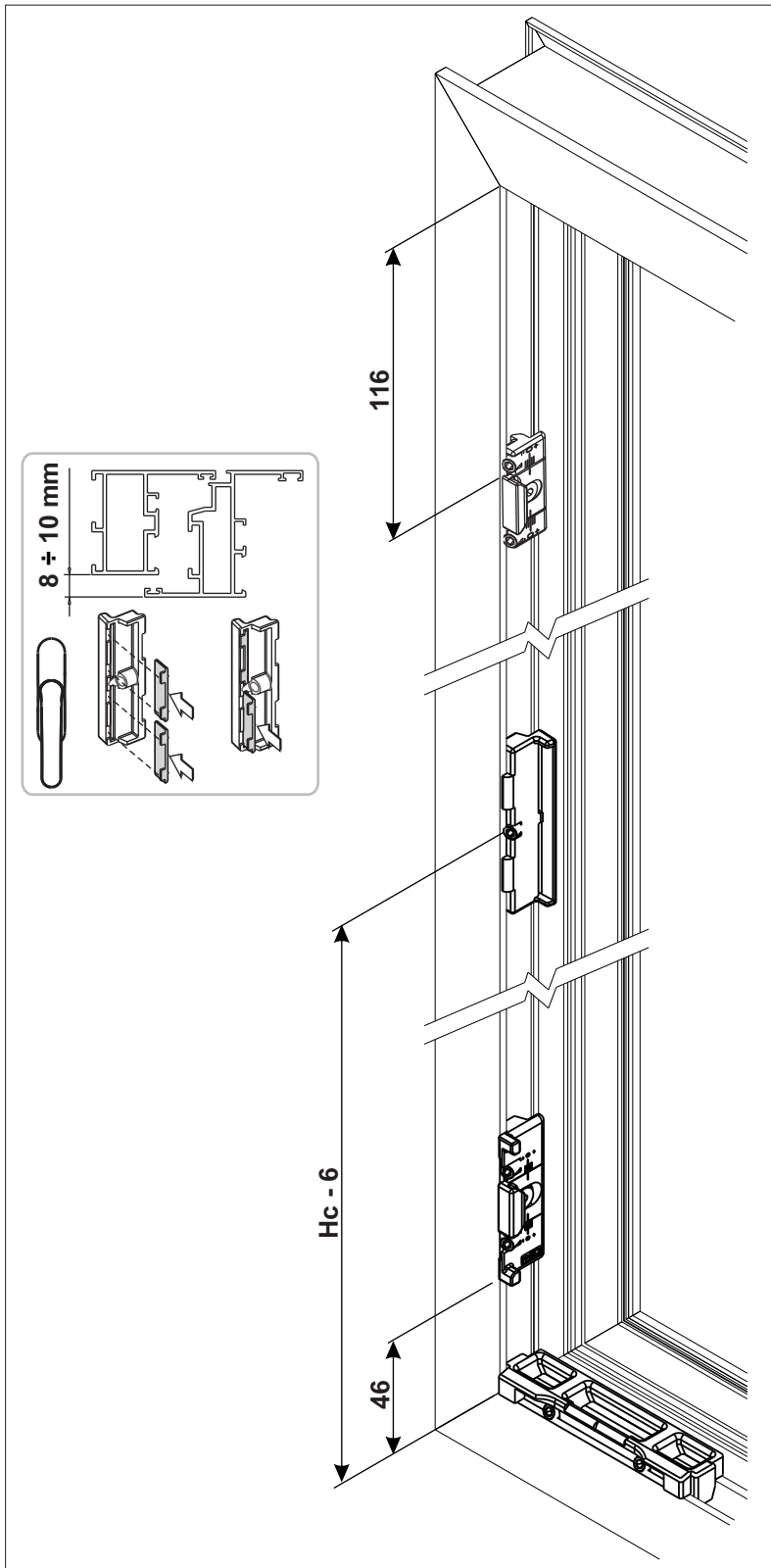
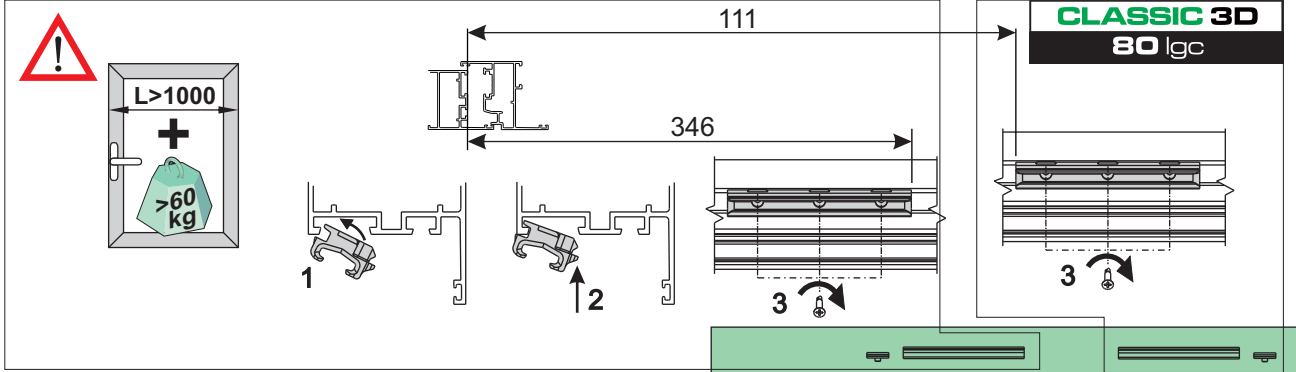

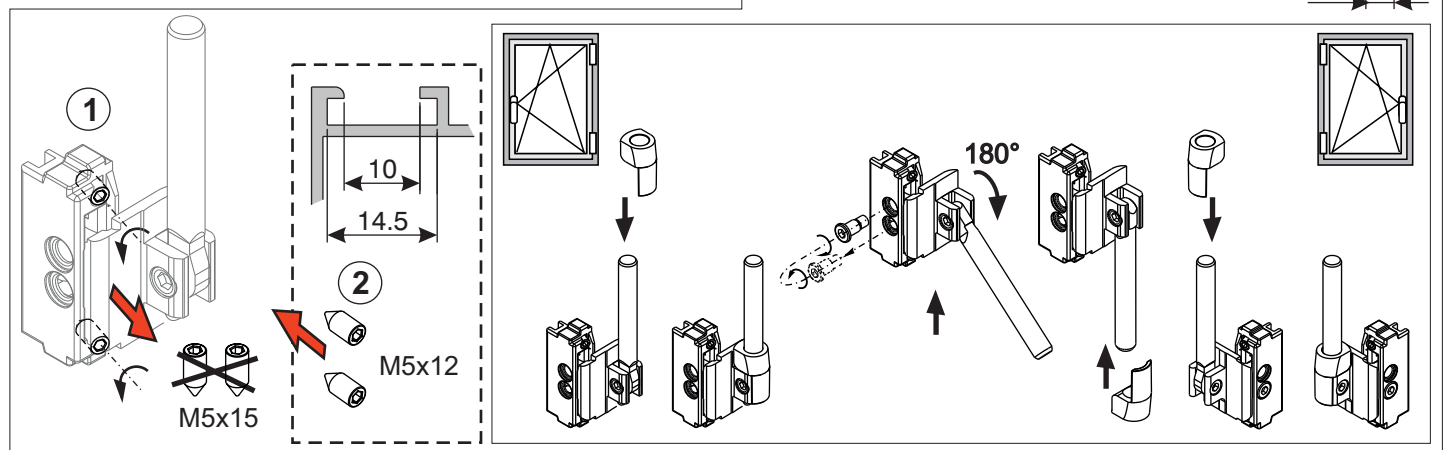
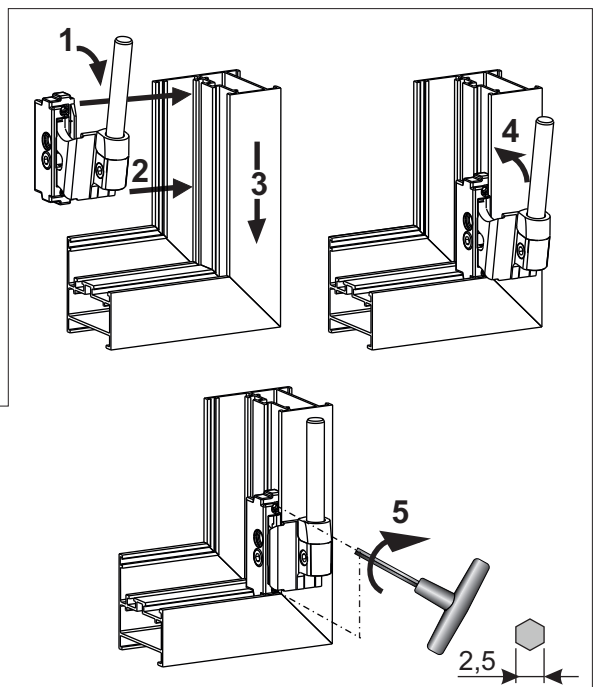
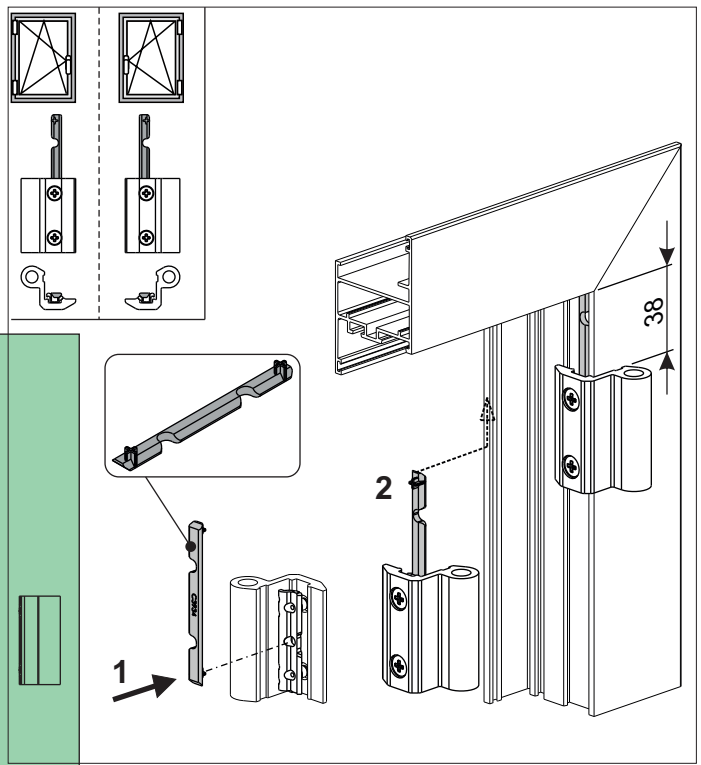
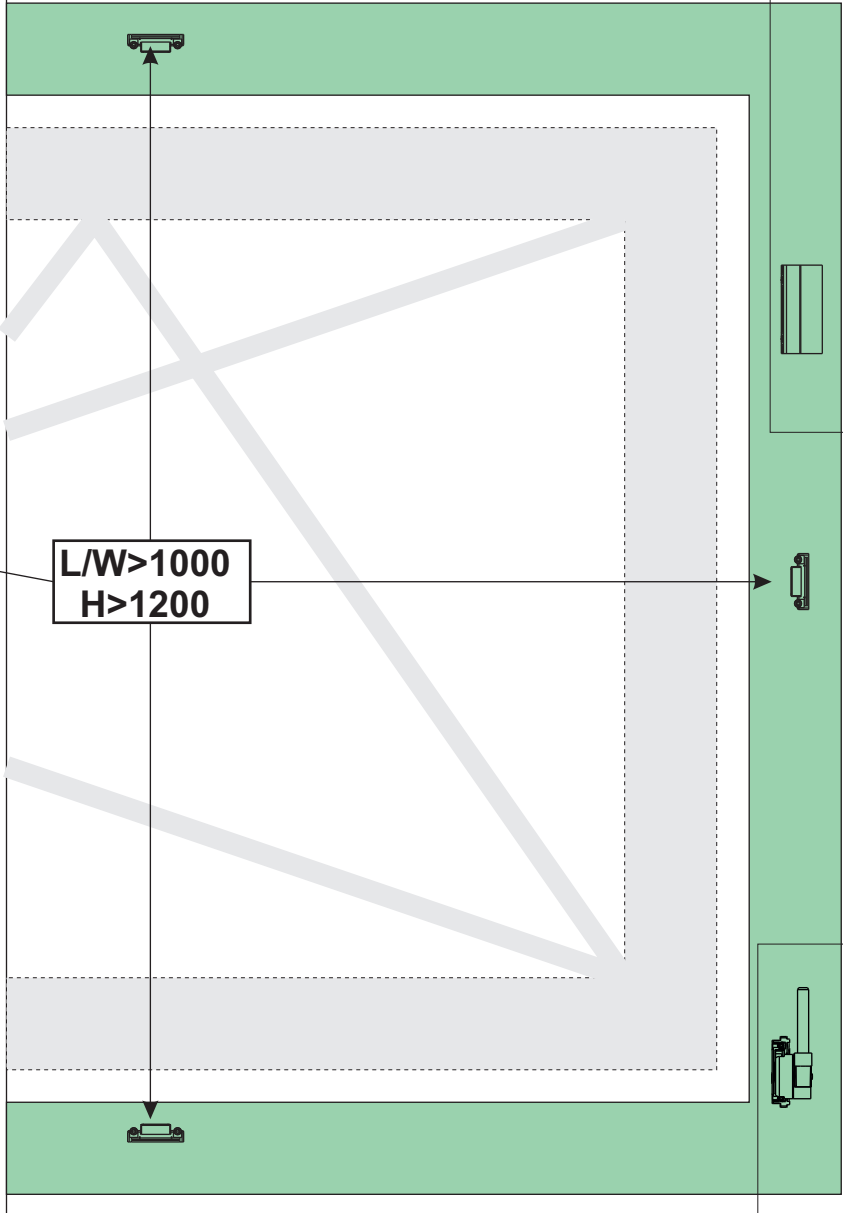

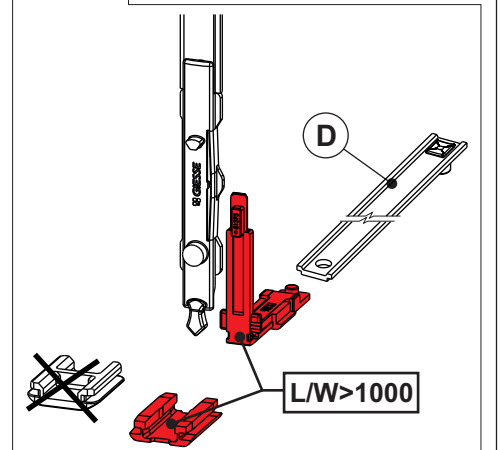
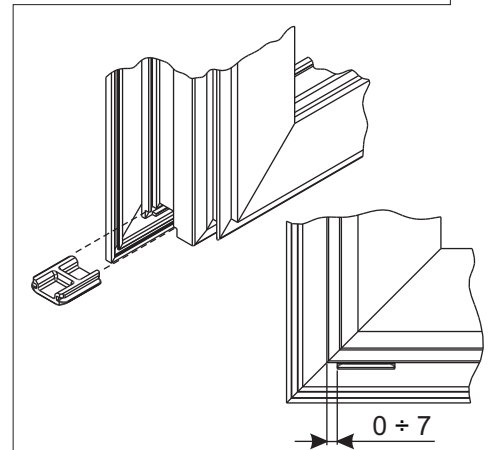
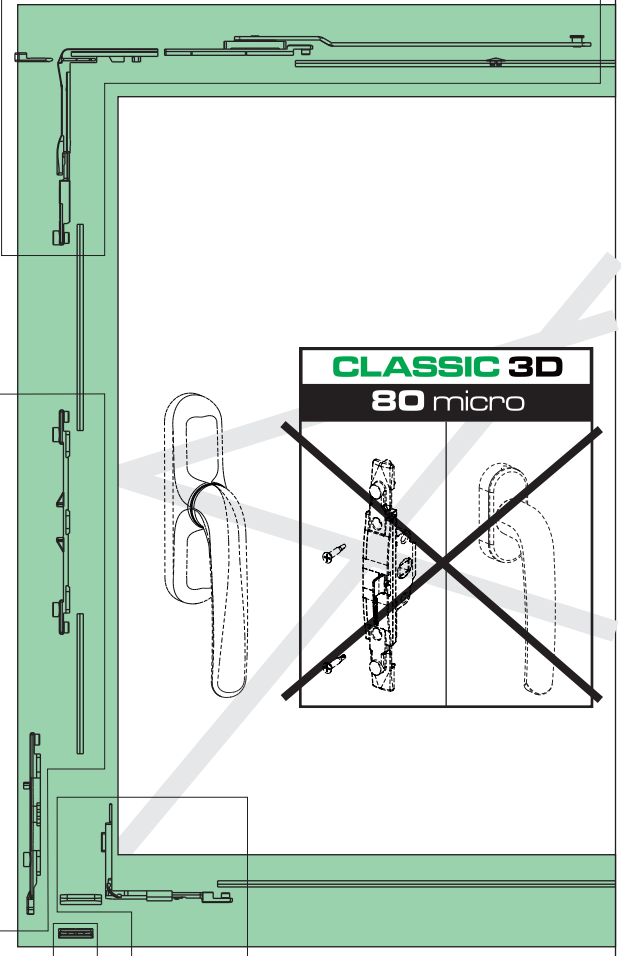
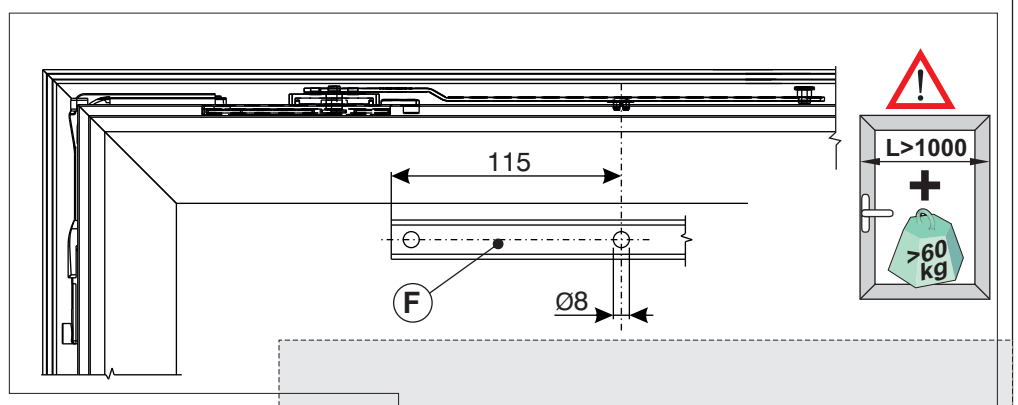
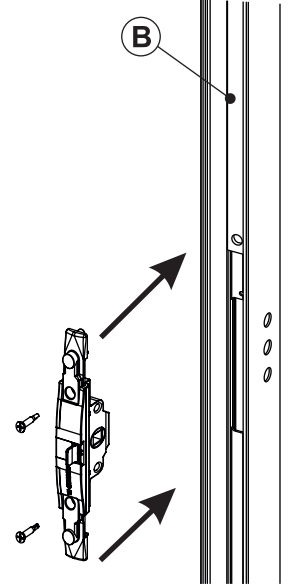
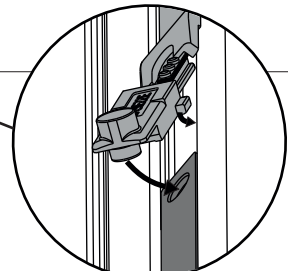
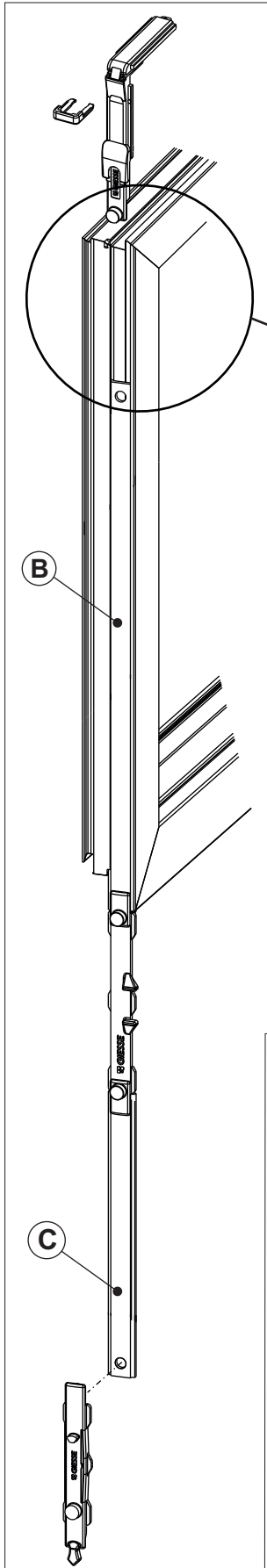

CLASSIC 3D

80 lgc

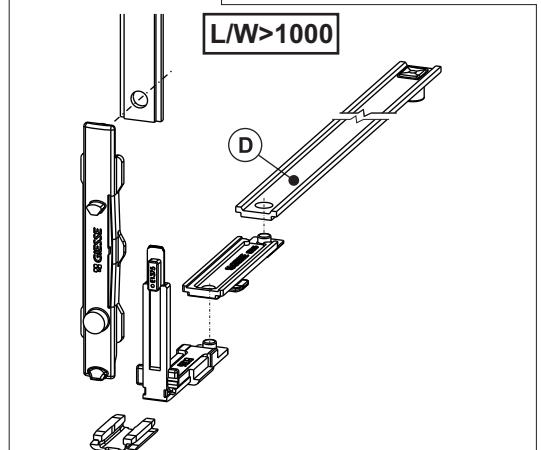
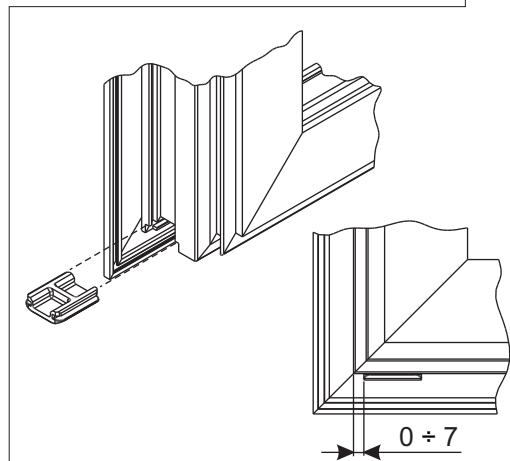
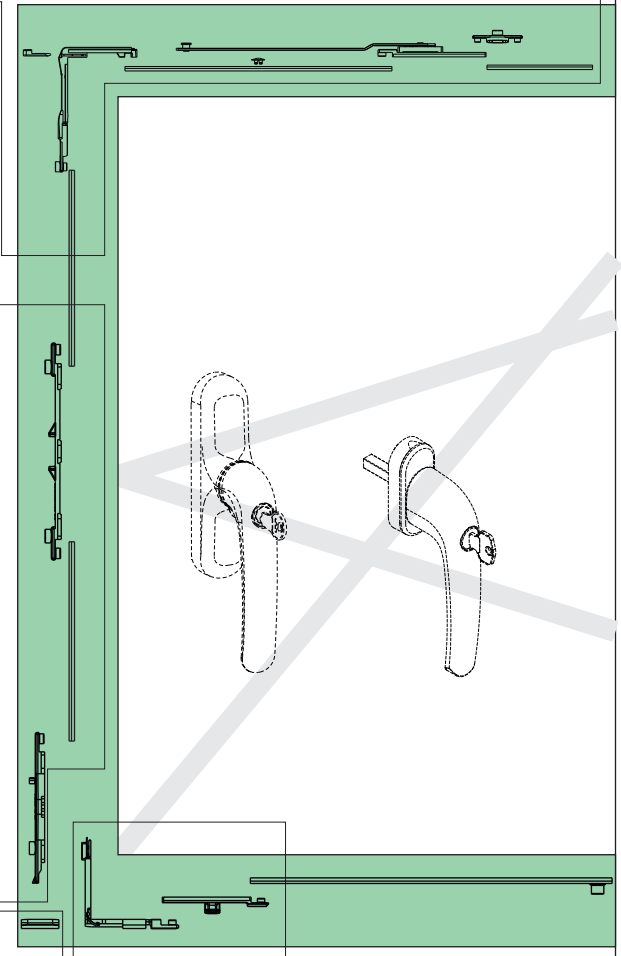
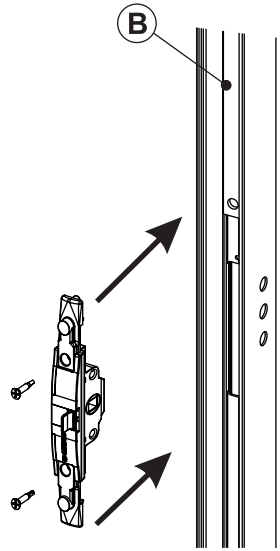
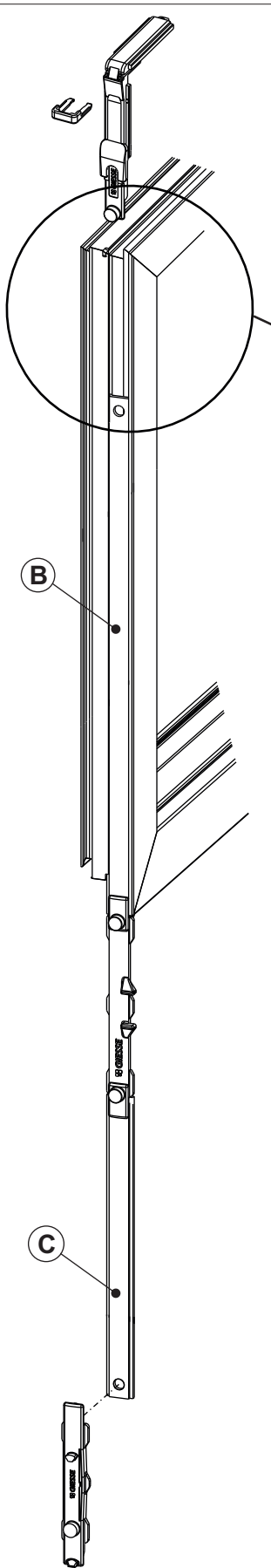
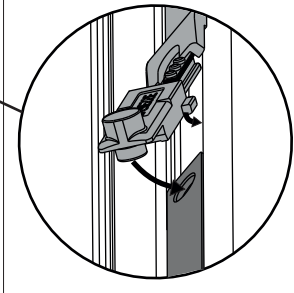
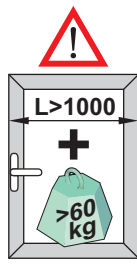
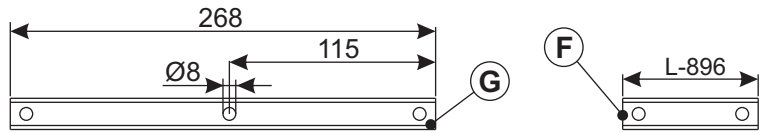

T0

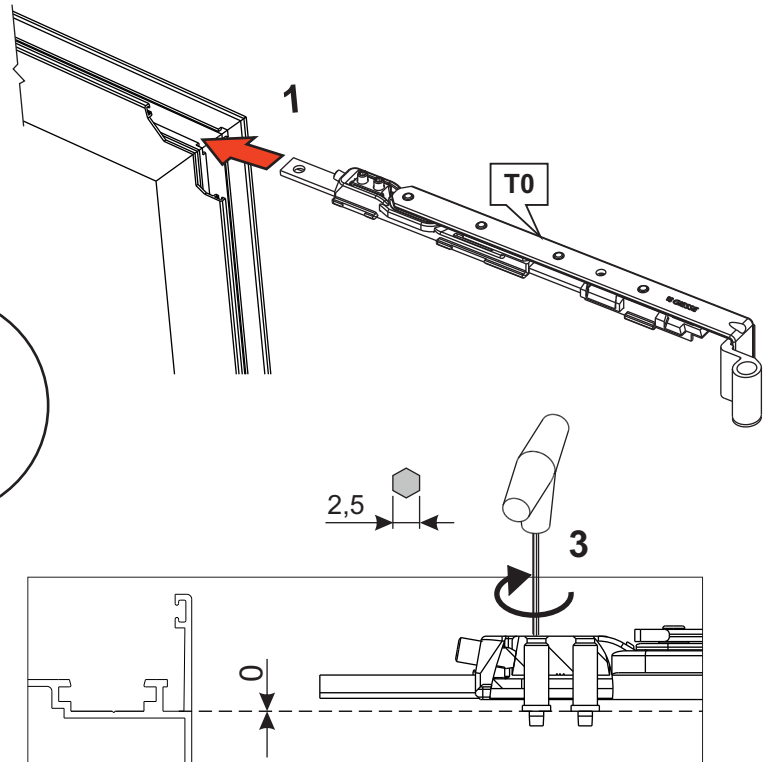
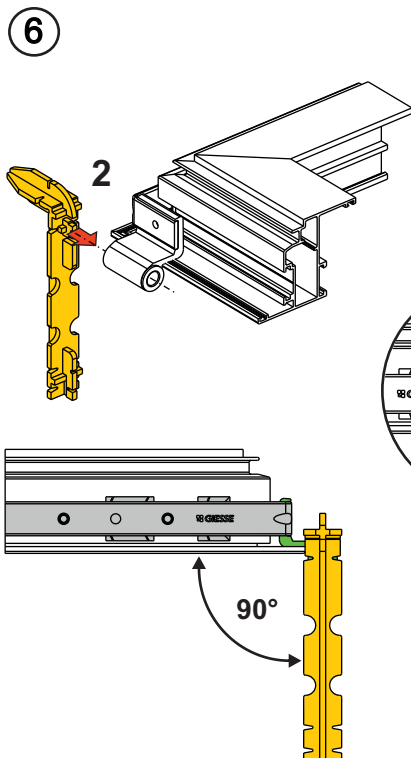
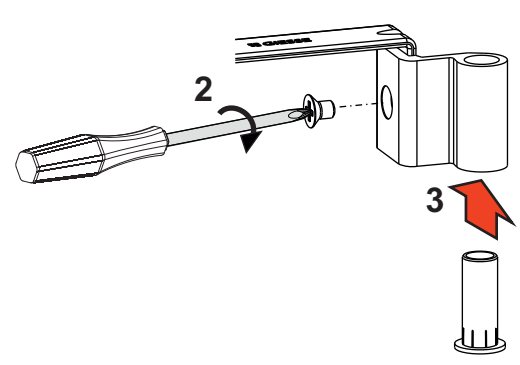
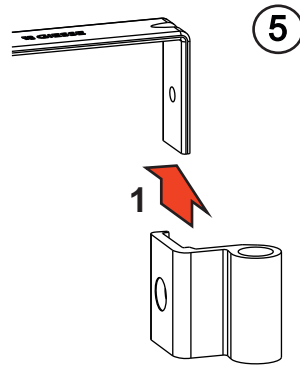
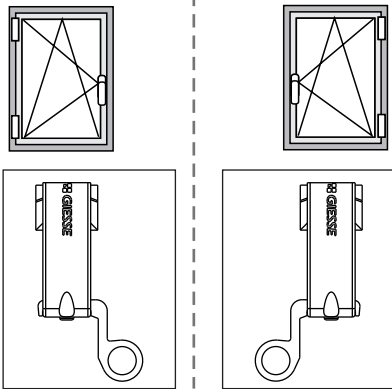
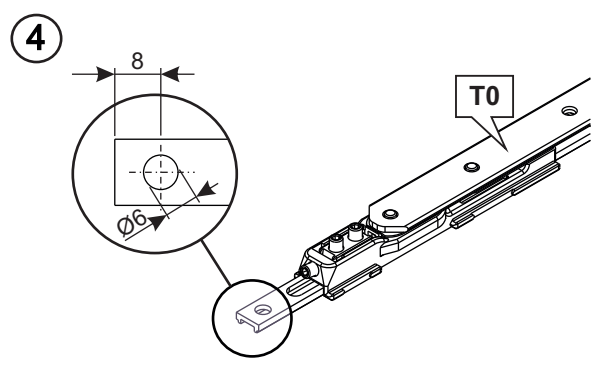
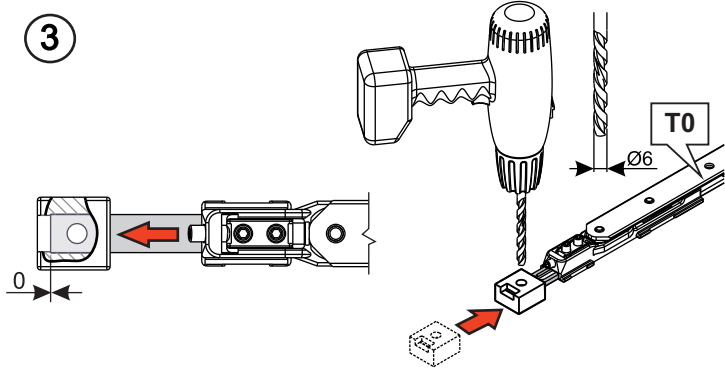
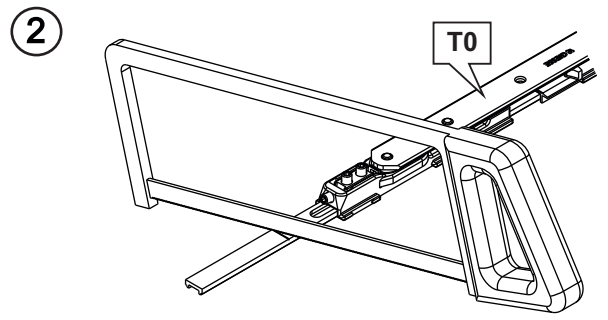
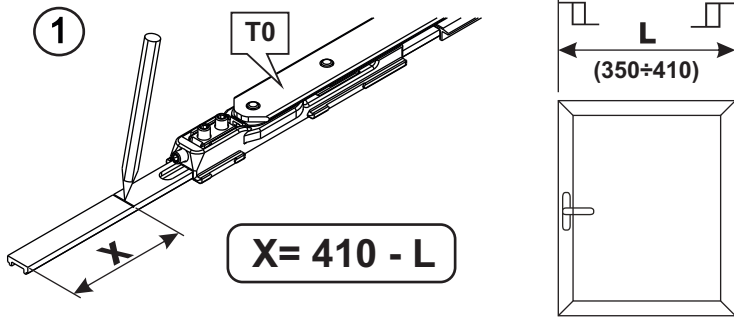

T1

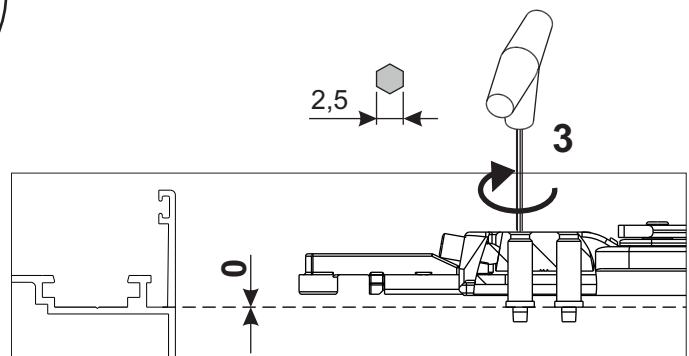
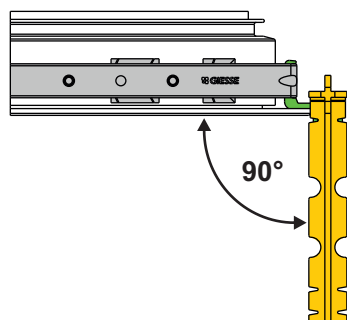
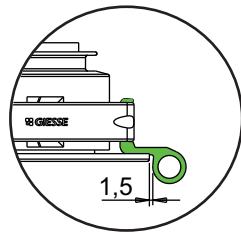
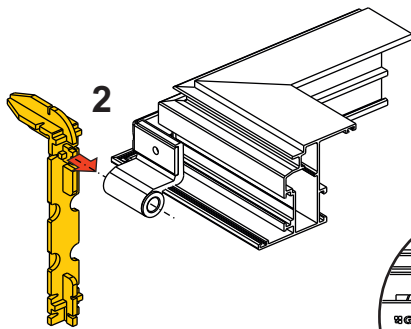
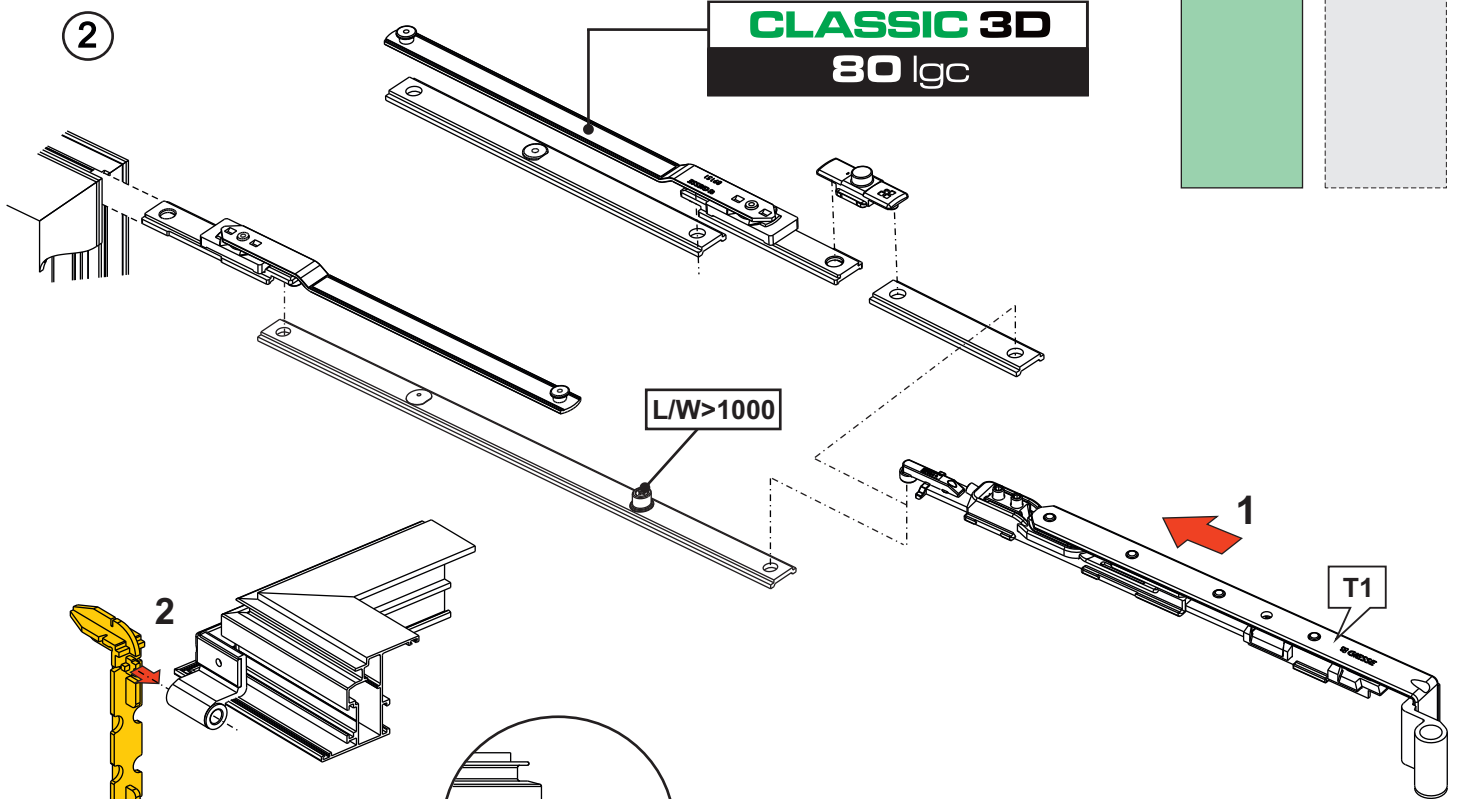
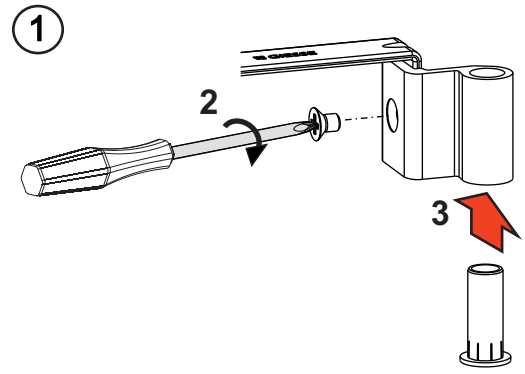
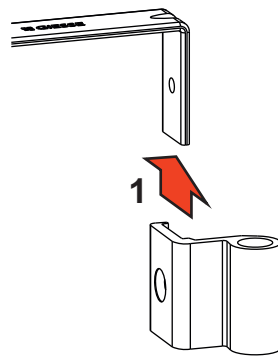
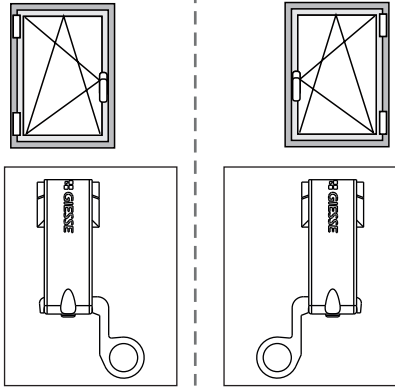

H > 1200

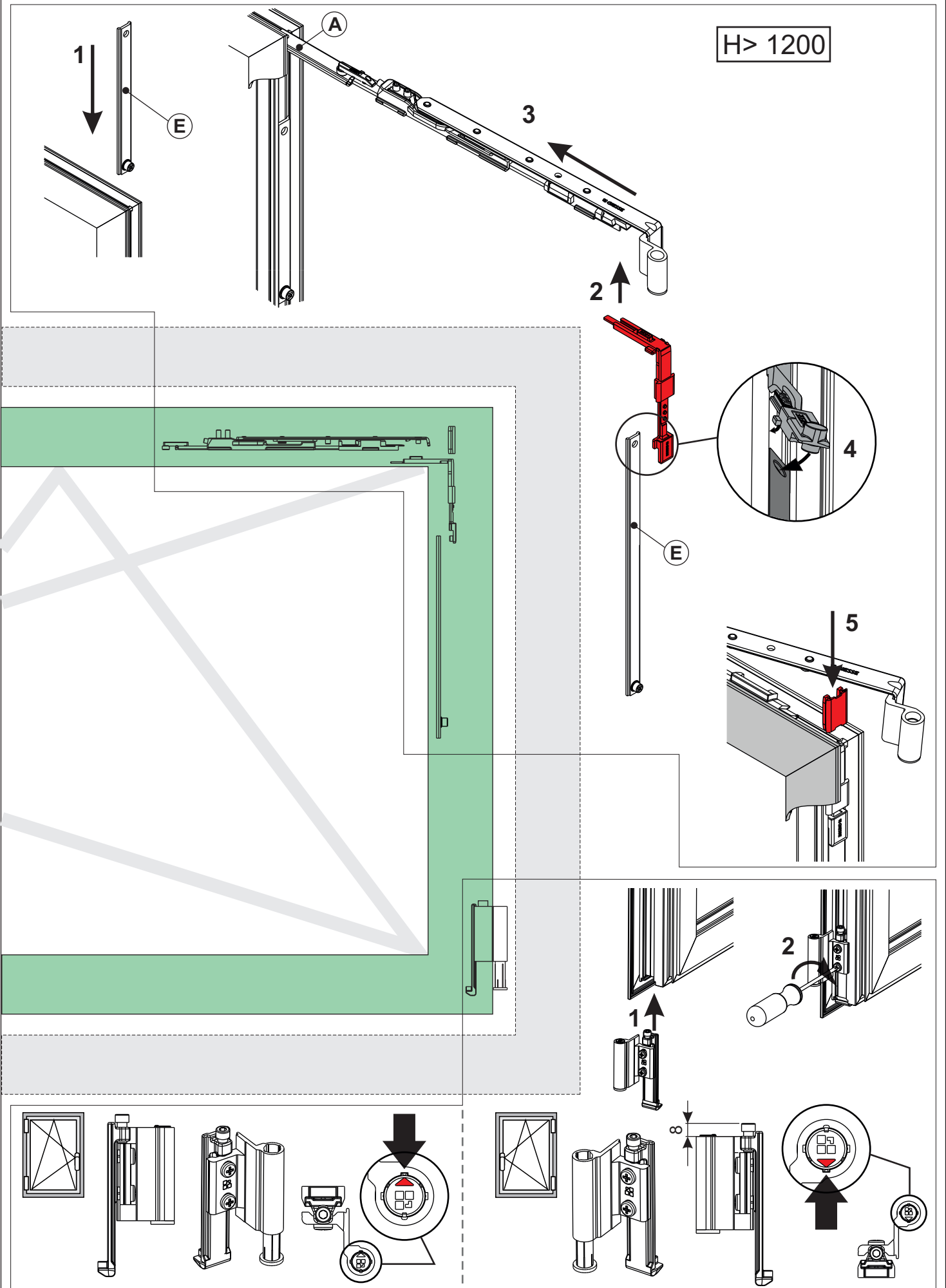

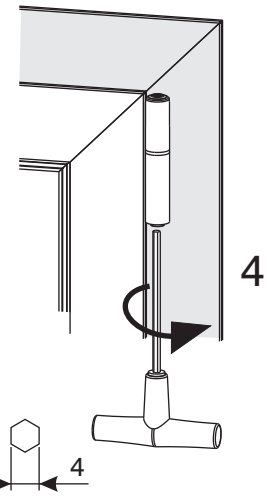
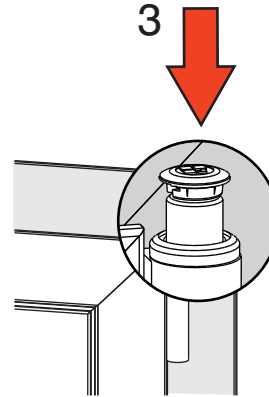
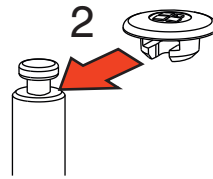
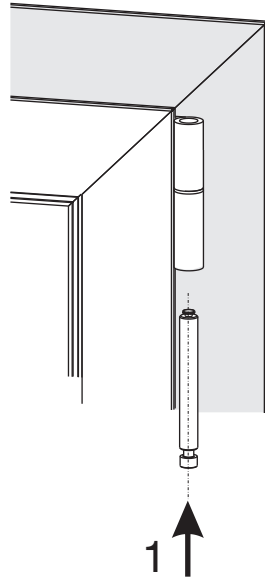
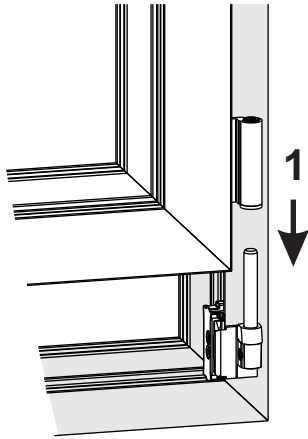
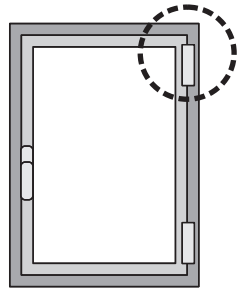
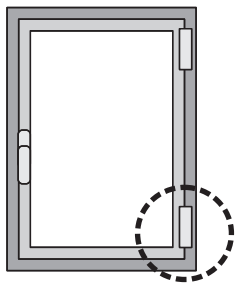

CLASSIC 3D
80 micro

***** Quote indicativa da verificare sull'anta installata e regolata con cremonese in posizione microventilazione
 Indicative distance to be checked on the leaf installed and adjusted in position with microventilation cremone

Cotas indicativas para el control de la hoja ensamblada y regulación cremona en posición de microventilación

Die Maße sind zu überprüfen auf den montierten Flügel, und reguliert mit dem Griff bei der Mikrobelüftung Position

Η απόσταση τοποθέτησης είναι ενδεικτική. Ελέγξτε αφού πρώτα τοποθετήσετε το φύλλο και βάλετε την σπανιολέτα στην θέση μικρό-εξαερισμού.

Cotes à vérifier sur l'ouvrant installé et réglé avec la crémonne en position micro-ventilation

