

FUTURA 3D
130

FUTURA 3D
130 lgc

FUTURA 3D
130 micro

FUTURA 3D
130 micro lgc

Dimensioni e Portate realizzabili - Dimensiones y Capacidades admitidas - Διαστάσεις και Βάρη πραγματοποιήσιμα - Possible Dimensions and Capacities - Zulässige Abmessungen und Gewichte - Dimensions et charges possibles

ATTENZIONE: Le portate e il perfetto funzionamento dell'accessorio vengono garantiti solo se non vi sono impedimenti nella movimentazione dell'anta che forzano in modo anomalo le cerniere (ad esempio spallature, tappi od altri elementi di arresto). In questo caso è obbligatorio l'utilizzo di un braccio limitatore FRIZ.

ΠΡΟΣΟΧΗ: Εγγυόμαστε για το βάρος του κουφώματος όταν δεν υπάρχουν εμπόδια κατά το άνοιγμα που εμποδίζουν τη σωστή λειτουργία των μεντεσέδων. Σ' αυτή την περίπτωση είναι υποχρεωτική η χρήση του κουμπιάσου φρένο.

ACHTUNG: Die Tragfähigkeit und einwandfreie Funktion des Beschlages sind nur dann gewährleistet, wenn die Flügelbewegung ungehindert, d.h. ohne übermäßige Beanspruchung der Bänder, erfolgt (z.B. durch Absätze, Kappen oder andere Hindernisse). In diesem Fall muss die Begrenzungsschere FRIZ verwendet werden.

ATENCIÓN: Las capacidades y el perfecto funcionamiento del accesorio están garantizados si no hay obstáculos en el movimiento de la hoja que fuercen de modo anómalo las bisagras (por ejemplo elementos de apoyo, capuchones u otros elementos de parada). En este caso es obligatorio utilizar el brazo limitador FRIZ.

CAUTION: The capacities and correct functioning of the accessory are only guaranteed if there are no obstacles preventing movement of the wing which force the hinges excessively (such as protrusions, stoppers or other stop elements). In such cases, you MUST use a FRIZ limiter arm.

ATTENTION : Les charges et le fonctionnement sont garantis si rien n'entrave le mouvement du vantail en soumettant les charnières à un effort anormal (par exemple, saillies, tampons ou autres dispositifs d'arrêt). Dans ce cas, il est obligatoire d'utiliser le bras limiteur FRIZ.

Spessore massimo del vetro impiegabile (senza camera d'aria) (mm) - Espesor máximo del cristal que se puede utilizar (sin cámara de aire) (mm)
Μέγιστη απόσταση τζαμιών (χωρίς το κενό) (mm) - Maximum possible thickness of glass (without air space) (mm)
Max. zulässige Glasstärke (ohne Luftzwischenraum) (mm) - Épaisseur maximale utilisable pour le vitrage (sans lame d'air) (mm)

3000	35	28	24	21	19	17	15	14	13	12	11	11	10	
2900	35	29	25	22	20	18	16	15	14	13	12	11	10	10
2800	36	30	26	23	20	18	17	15	14	13	12	11	11	10
2700	38	31	27	24	21	19	17	16	15	13	13	12	11	10
2600	39	33	28	25	22	20	18	16	15	14	13	12	12	11
2500	44	37	31	27	24	22	20	18	17	16	15	14	13	11
2400	46	38	33	29	25	23	21	19	18	16	15	14	13	12
2300	48	40	34	30	27	24	22	20	18	17	16	15	14	12
2200	50	42	36	31	28	25	23	21	19	18	17	16	15	13
2100	50	44	37	33	29	26	24	22	20	19	17	16	15	13
2000	50	46	39	34	31	27	25	23	21	20	18	17	16	14
1900	50	48	41	36	32	29	26	24	22	21	19	18	16	14
1800	50	50	44	38	34	31	28	25	23	22	20	18	16	14
1700	50	50	46	40	36	32	29	27	25	23	21	18	16	14
1600	50	50	49	43	38	34	31	29	26	24	21	18	16	14
1500	50	50	50	46	41	37	33	31	27	24	21	18	16	14
1400	50	50	50	49	44	39	36	32	27	24	21	18	16	
1300	50	50	50	50	47	42	38	32	27	24	21	18		
1200	50	50	50	50	50	46	38	32	27	24	21			
1100	50	50	50	50	50	46	38	32	27	24				
1000	50	50	50	50	50	46	38	32	27					
900	50	50	50	50	50	46	38	32						
800	50	50	50	50	50	46	38							
700	50	50	50	50	50	46								
600	50	50	50	50	50	46								

Non realizzabile
No puede realizarse
Μη πραγματοποιήσιμα
Not possible
Nicht möglich
Irréalizable

Larghezza anta (mm) - Anchura hoja (mm) - Πλάτος Φύλλου (mm) - Wing width (mm) - Flügelbreite (mm) - Largeur vantail (mm)

Peso massimo dell'anta (alluminio e vetro) - Peso máximo de la hoja (aluminio y cristal) - Μέγιστο βάρος Φύλλου (Αλουμίνιο & Τζάμι)
Maximum wing weight (aluminium and glass) - Max. Flügelgewicht (Aluminium und Glas) - Poids maximum du vantail (aluminium et vitrage)

3000	130	130	130	130	130	130	130	130	130	130	130	130	130	
2900	130	130	130	130	130	130	130	130	130	130	130	130	130	130
2800	130	130	130	130	130	130	130	130	130	130	130	130	130	130
2700	130	130	130	130	130	130	130	130	130	130	130	130	130	130
2600	130	130	130	130	130	130	130	130	130	130	130	130	130	130
2500	140	140	140	140	140	140	140	140	140	140	140	140	140	130
2400	140	140	140	140	140	140	140	140	140	140	140	140	140	130
2300	140	140	140	140	140	140	140	140	140	140	140	140	140	130
2200	140	140	140	140	140	140	140	140	140	140	140	140	140	130
2100	140	140	140	140	140	140	140	140	140	140	140	140	140	130
2000	140	140	140	140	140	140	140	140	140	140	140	140	139	125
1900	140	140	140	140	140	140	140	140	140	140	140	140	132	118
1800	140	140	140	140	140	140	140	140	140	140	140	140	133	125
1700	140	140	140	140	140	140	140	140	140	140	134	126	118	118
1600	140	140	140	140	140	140	140	140	140	140	135	126	118	111
1500	140	140	140	140	140	140	140	140	137	127	118	111	104	99
1400	140	140	140	140	140	140	140	140	138	127	118	110	104	97
1300	140	140	140	140	140	140	140	128	118	110	103	96		
1200	140	140	140	140	140	140	129	118	109	101	95			
1100	140	140	140	140	140	130	118	108	100	93				
1000	140	140	140	140	131	118	108	99	91					
900	140	140	140	133	118	106	97	89						
800	140	140	135	118	105	95	86							
700	140	138	118	104	92	83								
600														

Non realizzabile
No puede realizarse
Μη πραγματοποιήσιμα
Not possible
Nicht möglich
Irréalizable

Larghezza anta (mm) - Anchura hoja (mm) - Πλάτος Φύλλου (mm) - Wing width (mm) - Flügelbreite (mm) - Largeur vantail (mm)

Lubrificare con prodotti a base di vaselina sia le guide che tutti i meccanismi prima del loro inserimento.

Impiegare astine di collegamento in poliammide GIESSE o in alternativa in alluminio con trattamento di ossidazione e non di verniciatura. Eseguire sull'anta mobile le lavorazioni indicate su questo documento.

Si garantisce il funzionamento dell'accessorio descritto in queste istruzioni solo se l'infisso è stato installato a regola d'arte, quindi in squadra e senza impedimenti nell'apertura totale (a 180°) dell'anta.

Qualora questo non sia possibile è d'obbligo l'utilizzo di elementi limitatori d'apertura quali il Braccio FRIZ GIESSE.

Lubricar con productos a base de vaselina tanto las guías como todos los mecanismos antes de introducirlos.

Utilizar varillas de conexión de poliamida GIESSE o en alternativa de aluminio con tratamiento de oxidación y sin pintura.

Realizar en la hoja móvil las preparaciones indicadas en este documento.

Se garantiza el funcionamiento del accesorio descrito en estas instrucciones sólo si el bastidor se ha instalado correctamente, es decir, en escuadra y sin obstáculos en la apertura total (a 180°) de la hoja.

En caso de que esto no sea posible, es obligatorio utilizar elementos limitadores de la apertura, como el Brazo FRIZ GIESSE.

Λιπαίνετε με προϊόντα που έχουν βάση τη βαζελίνη τους οδηγούς και όλους τους μηχανισμούς πριν την τοποθέτησή τους.

Κόψτε και τρυπήστε λαμάκια από πολυαμίδιο GIESSE ή εναλλακτικά λαμάκι αλουμινίου ανοδιωμένο και όχι βαμμένο ηλεκτροστατικά.

Συνεχίστε με το φύλλο όπως βλέπετε στις οδηγίες.

Εγγυόμαστε τη λειτουργία των εξαρτημάτων που περιγράφονται στις οδηγίες μόνο αν το κούφωμα είναι κατασκευασμένο με τις προδιαγραφές του κατασκευαστή και τοποθετημένο σωστά, και χωρίς να υπάρχουν εμποδιά κατά το άνοιγμά του στις 180°. Αν αυτό δεν είναι εφικτό υποχρεωτικά θα πρέπει να χρησιμοποιήσετε εξαρτήματα που σταματάνε το κούφωμα όπως το Φρένο - Stop της GIESSE.

Use vaseline-based products to lubricate both the guides and all the mechanisms before inserting them.

Use GIESSE polyamide connecting rods or aluminium connecting rods which have been subject to oxidation treatment and not painted.

Carry out all the machining operations on the mobile wing indicated in this document.

Correct functioning of the accessory described in these instructions is only guaranteed if the window has been installed correctly, that is, flush and without obstacles preventing total wing opening (at 180°).

If this is not possible, you MUST use opening limiter elements such as the GIESSE FRIZ arm.

Die Führungen und alle Getriebeteile vor dem Einbau mit Vaseline einfeften.

Polyamid-Verbindungsstangen von GIESSE oder Verbindungsstangen aus eloxiertem und unlackiertem Aluminium verwenden.

Am Flügel die in dieser Anleitung angegebenen Bearbeitungen ausführen.

Die einwandfreie Funktion des in dieser Anleitung beschriebenen Beschlags ist nur dann gewährleistet, wenn das Fenster sachgerecht montiert wurde, d.h. lotrecht und ohne Hindernisse bei der vollständigen Öffnung (180°) des Flügels.

Sollte dies nicht möglich sein, müssen Öffnungsbegrenzer, wie beispielsweise die Schere FRIZ GIESSE eingesetzt werden.

Avant tout montage, lubrifier les guides et tous les mécanismes avec des produits à base de vaseline.

Utiliser des tringles en polyamide GIESSE ou en aluminium ayant subi un traitement contre l'oxydation et non un vernissage.

Effectuer sur l'ouvrant les usinages indiqués dans le présent document.

Le bon fonctionnement de l'accessoire qui est décrit dans les présentes instructions est garanti uniquement si la fenêtre est montée dans les règles de l'art, c'est-à-dire à angle droit et sans que l'ouverture totale (à 180°) du vantail soit entravée.

Si cela est impossible, il est obligatoire d'utiliser des éléments limitant l'ouverture comme le bras FRIZ GIESSE.

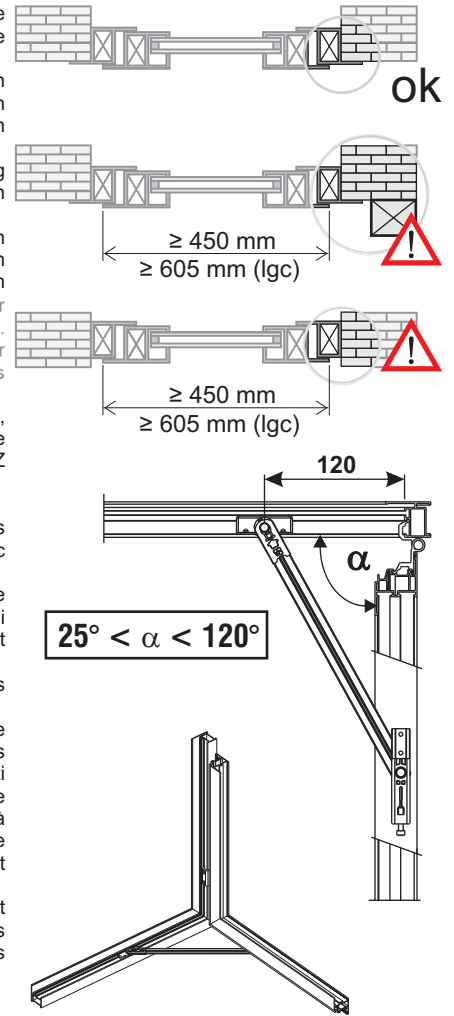

LAVORAZIONI PRELIMINARI SU ANTA MOBILE - OPERACIONES PRELIMINARES EN LA HOJA MÓVIL - ΠΡΟΕΡΓΑΣΙΕΣ ΣΤΟ ΦΥΛΛΟ - PRELIMINARY MOBILE WING MACHINING OPERATIONS - BEARBEITUNGEN AM FLÜGEL - USINAGES PRELIMINAIRES A PRATIQUER SUR L'OUVRANT

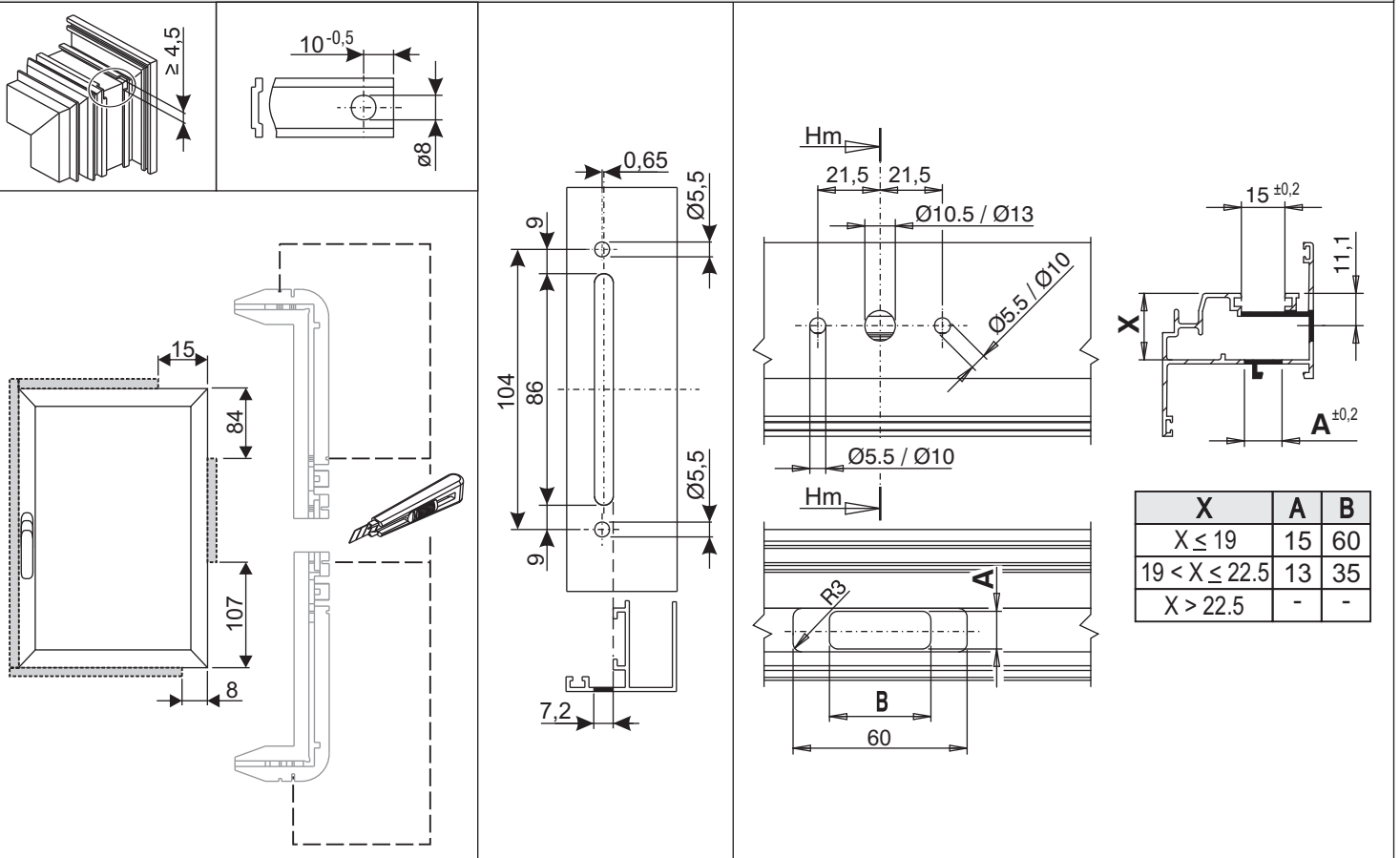

REGOLAZIONI - REGULACIONES - ΠΥΘΜΙΣΕΙΣ - ADJUSTMENTS - EINSTELLUNGEN - REGLAGES

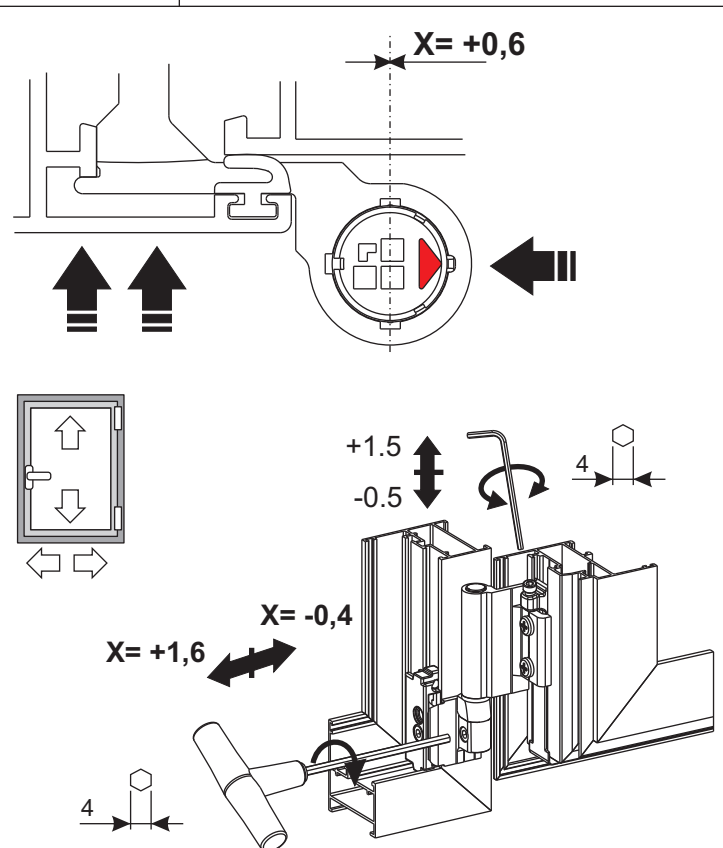
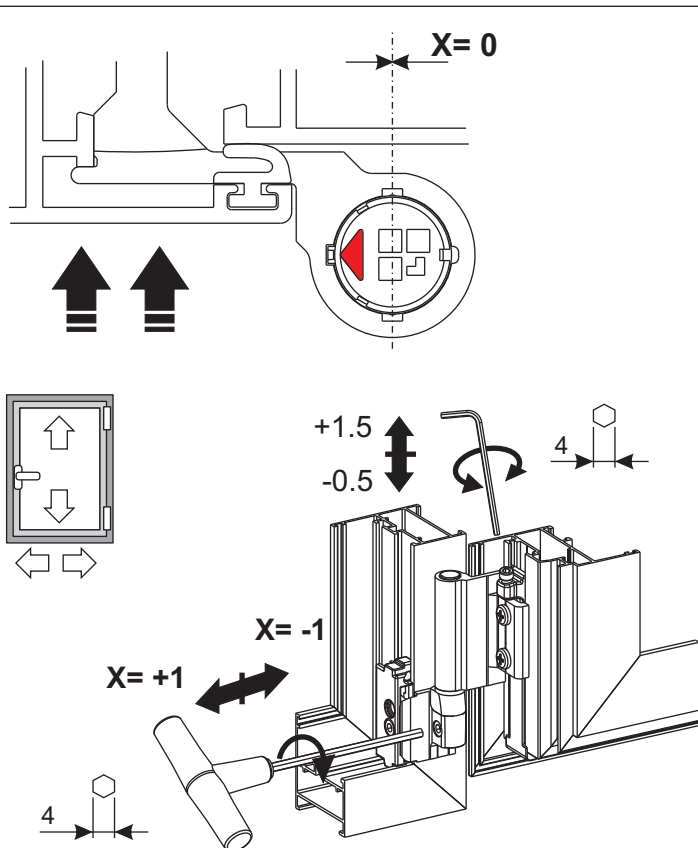
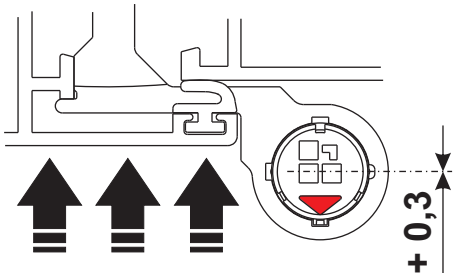
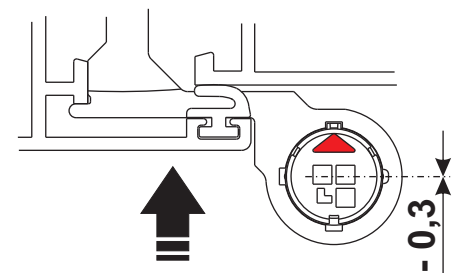
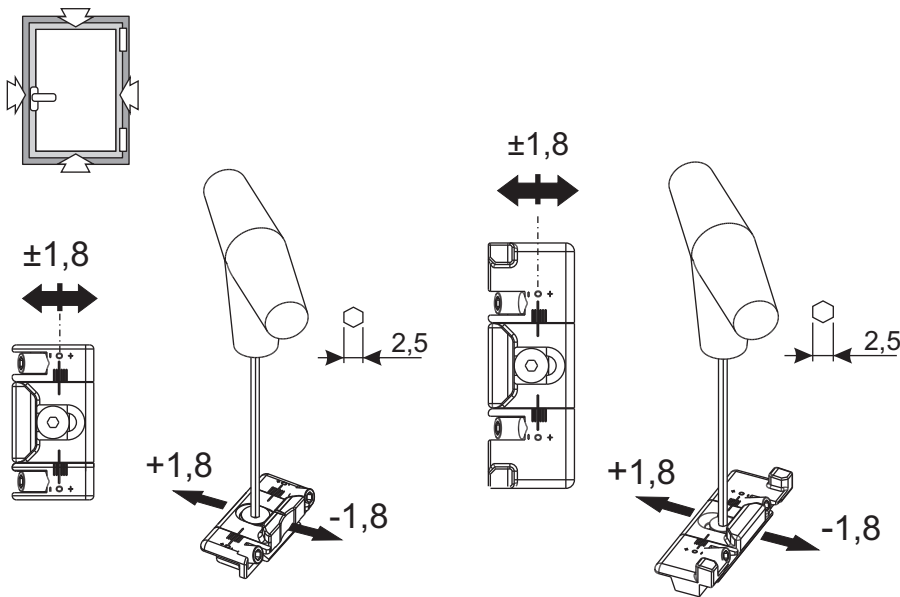
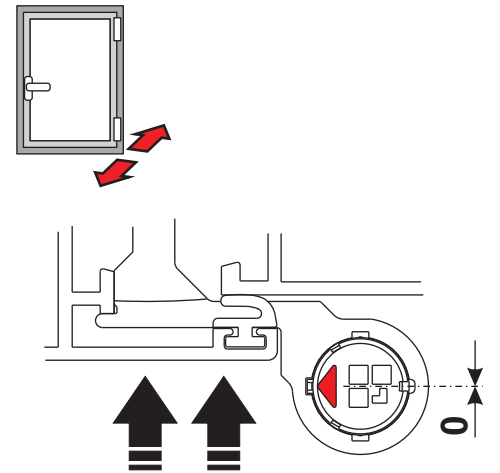
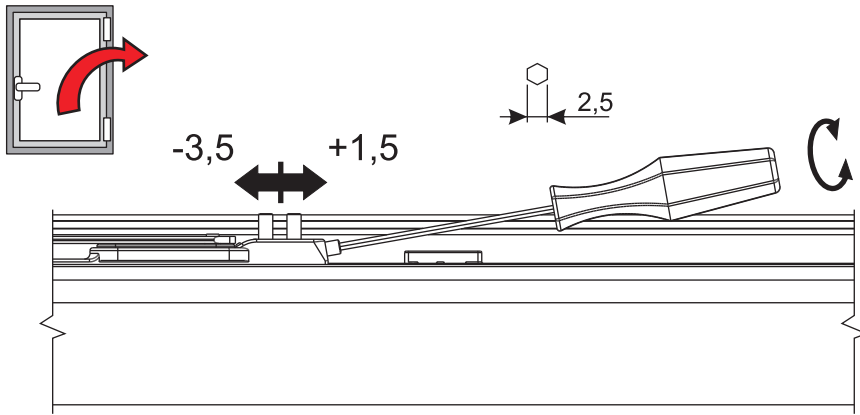

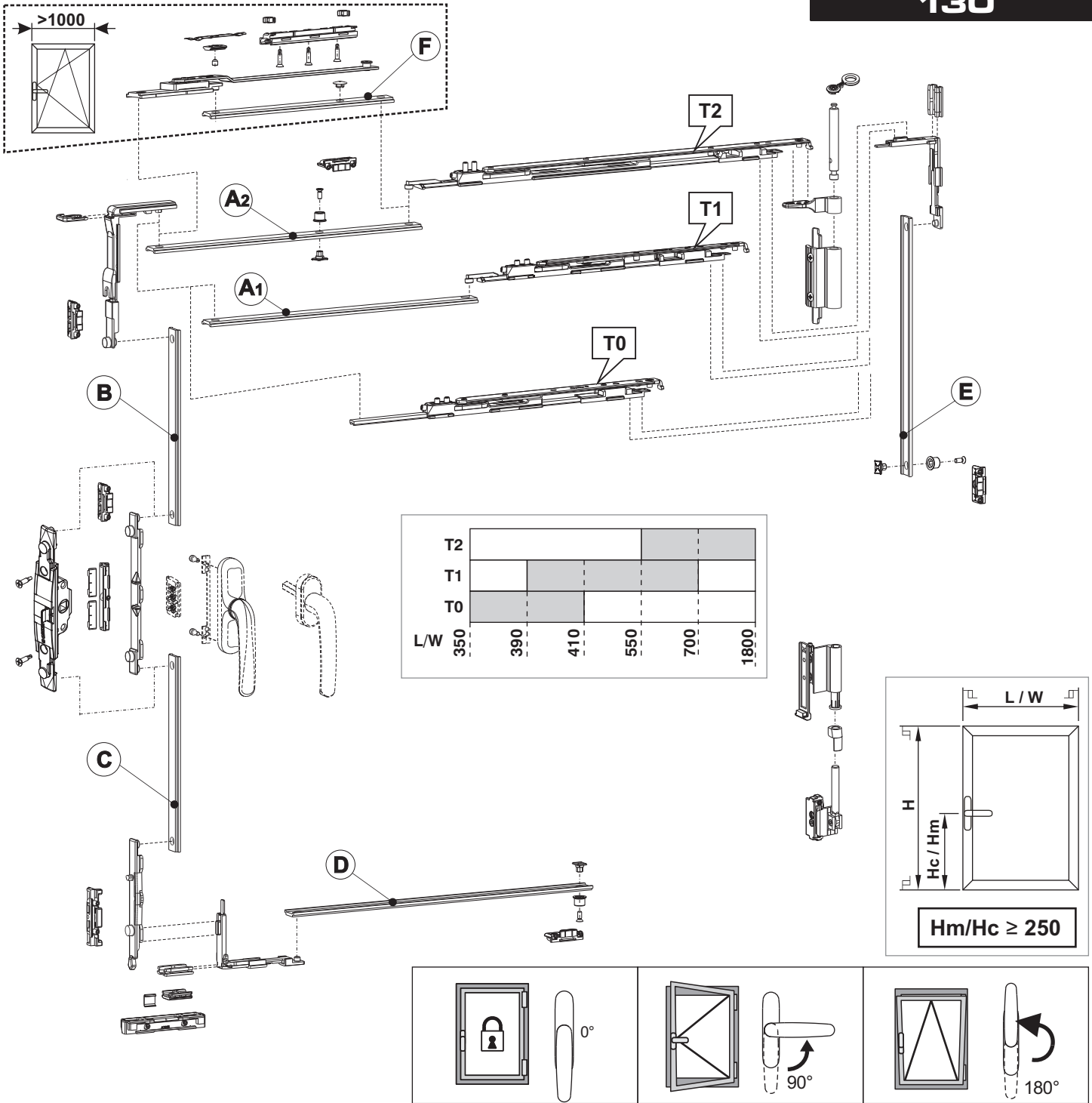

3000	B E	B=H-Hc-207 C=Hc-207 E=H/2-69	A1 E	A1=L-355 B=H-Hc-207 C=Hc-207 E=H/2-69	A2 E	A2=L-510 B=H-Hc-207 C=Hc-207 E=H/2-69	F E	F=L-607 B=H-Hc-207 C=Hc-207 D=L/2-69 E=H/2-69				
	C		C		C		C					
1200	B	B=H-Hc-207 C=Hc-207	A1	A1=L-355 B=H-Hc-207 C=Hc-207	A2	A2=L-510 B=H-Hc-207 C=Hc-207	D F	F=L-607 B=H-Hc-207 C=Hc-207 D=L/2-69				
	C		C		C		C					
600							D					
	350	T0	410	390	T1	700	550	T2	1000	1001	T2	1800

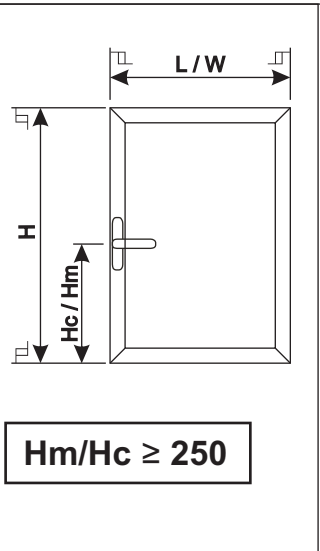
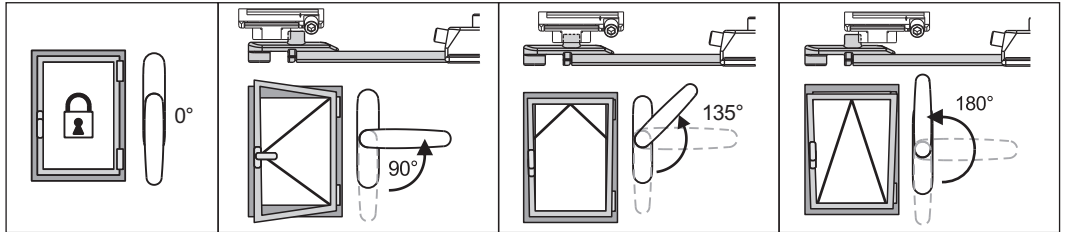
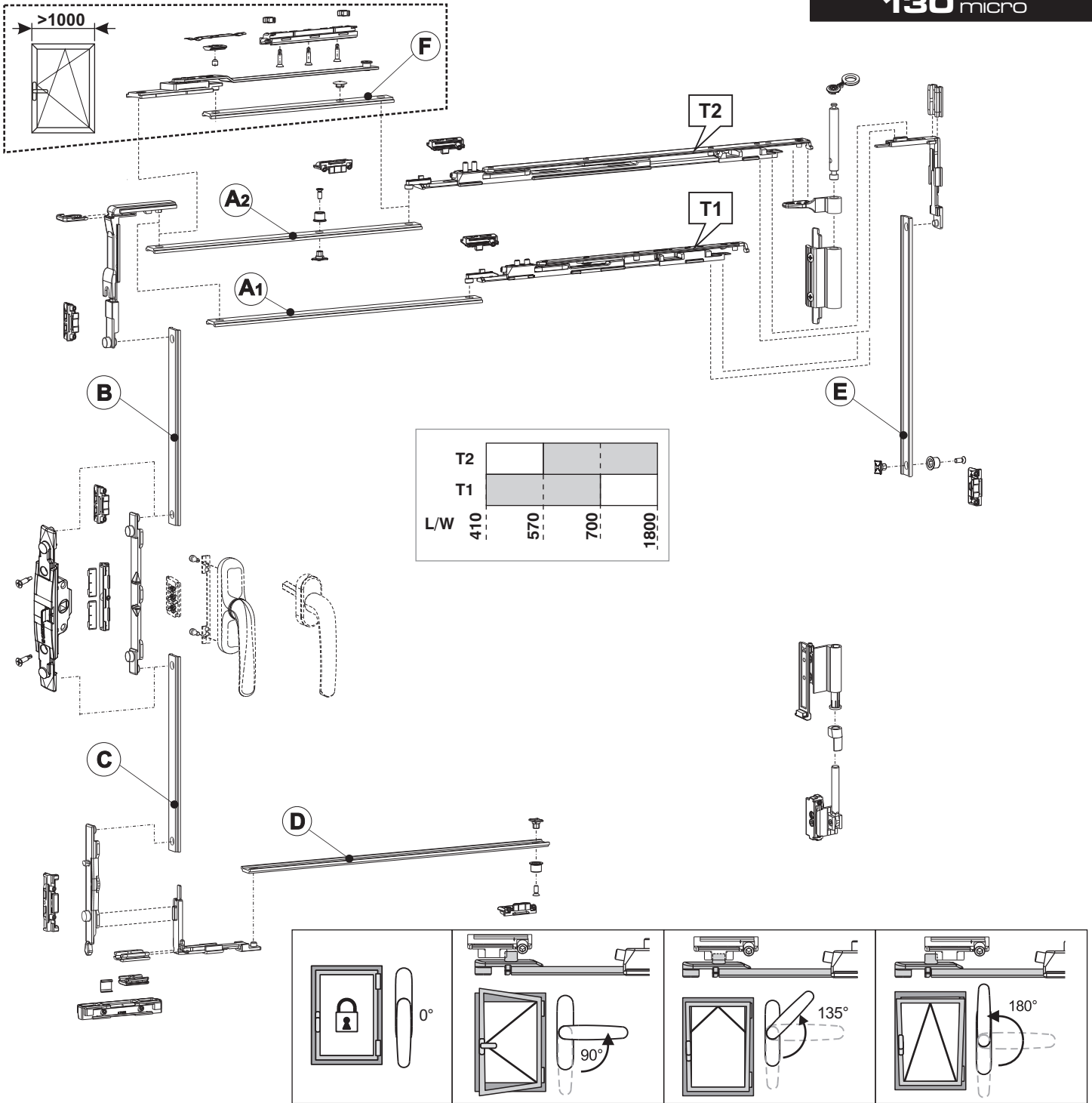

3000	A1	A1=L-355 B=H-Hc-207 C=Hc-207 E=H/2-69	A2	A2=L-510 B=H-Hc-207 C=Hc-207 E=H/2-69	F	F=L-607 B=H-Hc-207 C=Hc-207 D=L/2-69 E=H/2-69
	B		B		B	
1200	A1	A1=L-355 B=H-Hc-207 C=Hc-207	A2	A2=L-510 B=H-Hc-207 C=Hc-207	F	F=L-607 B=H-Hc-207 C=Hc-207 D=L/2-69
600	B		B		B	
	C		C		C	
					D	
	410	T1	700	570	T2	1800

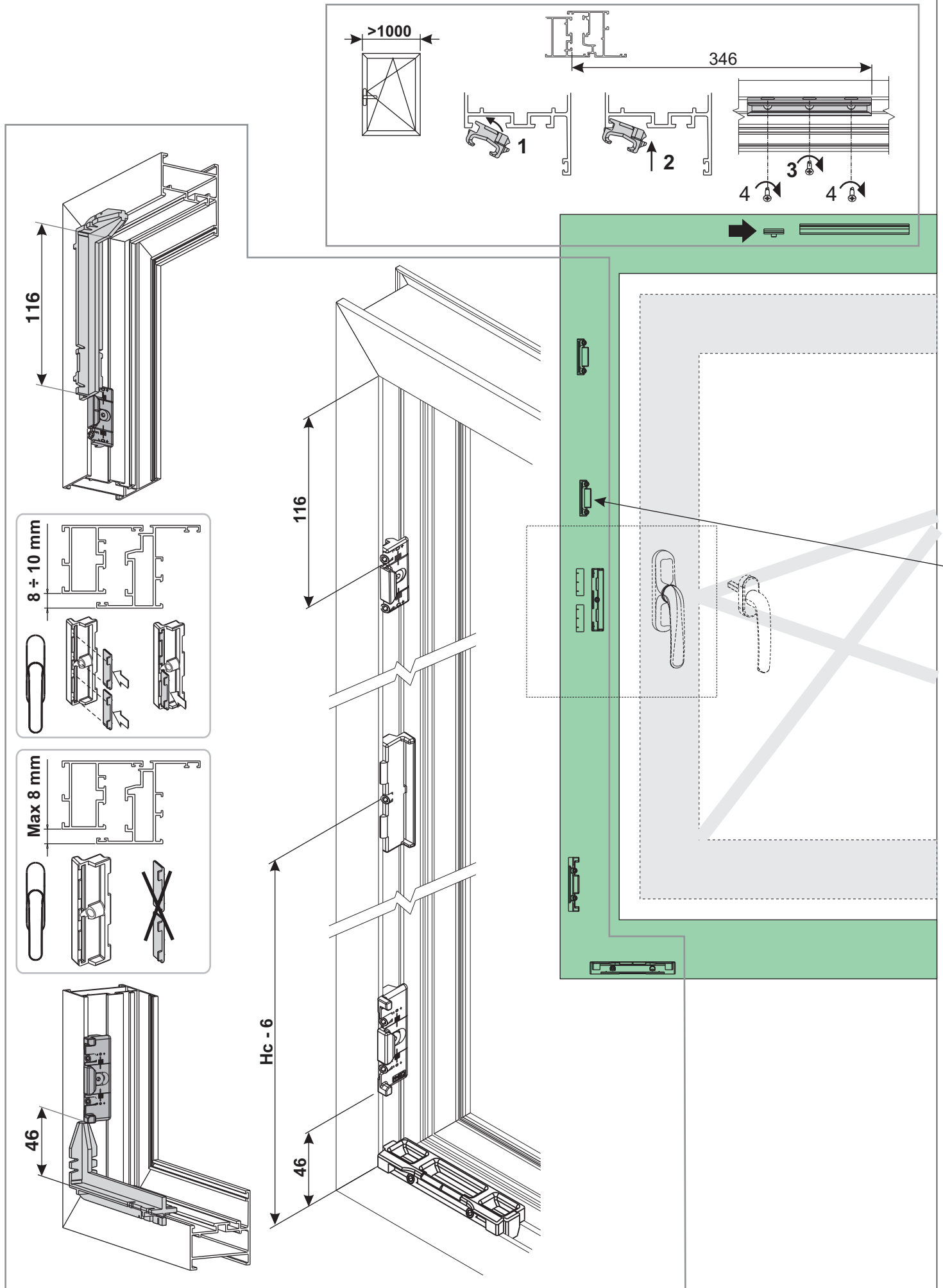

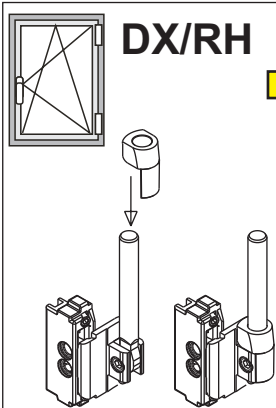
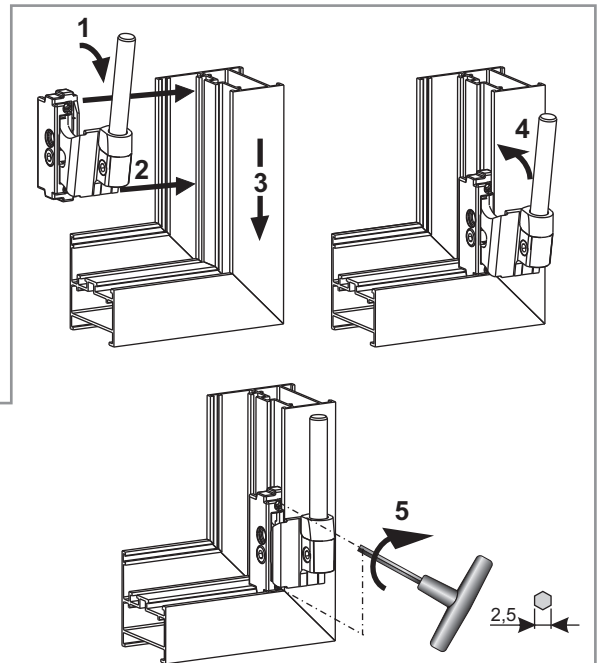
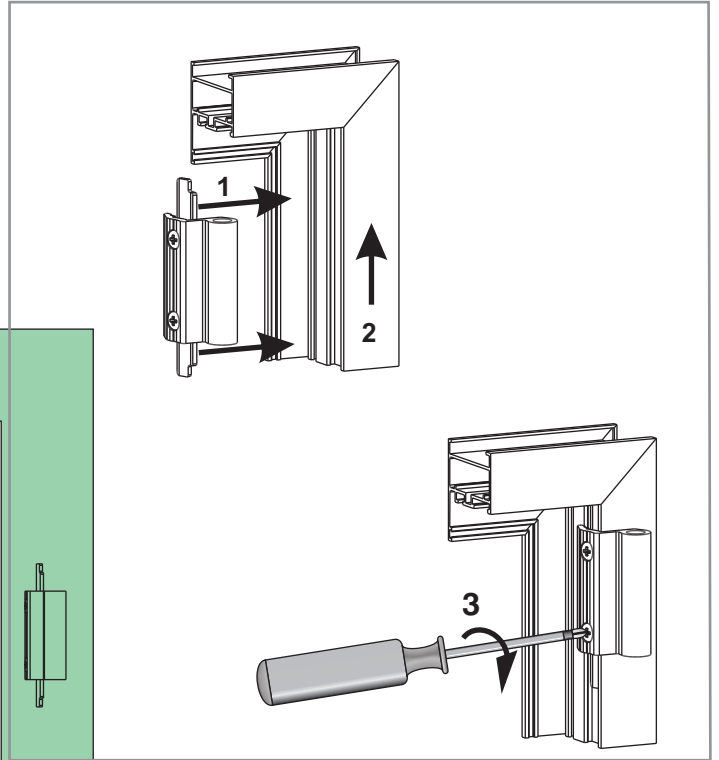
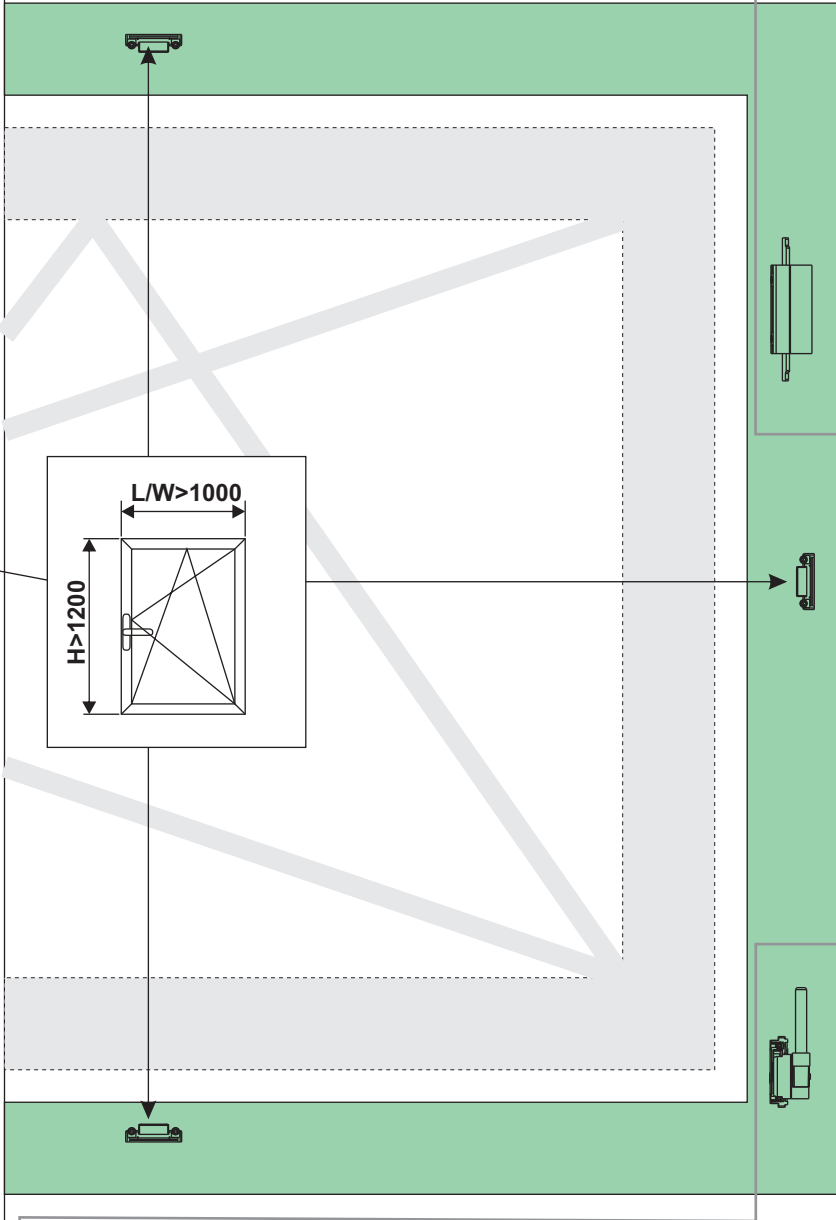

DX/RH

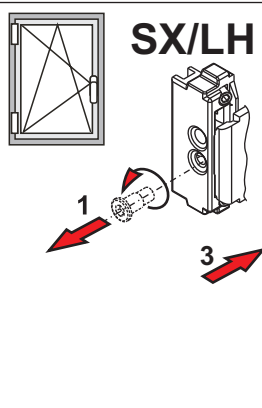

SX/LH

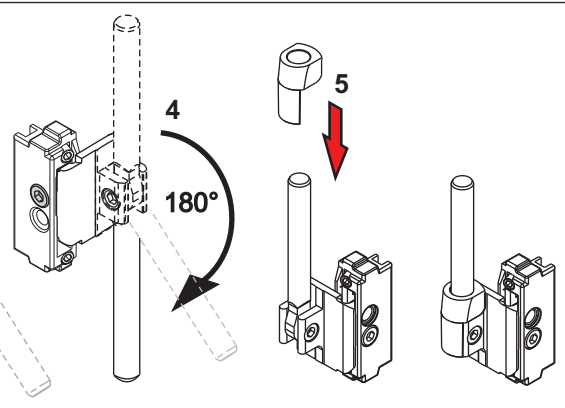

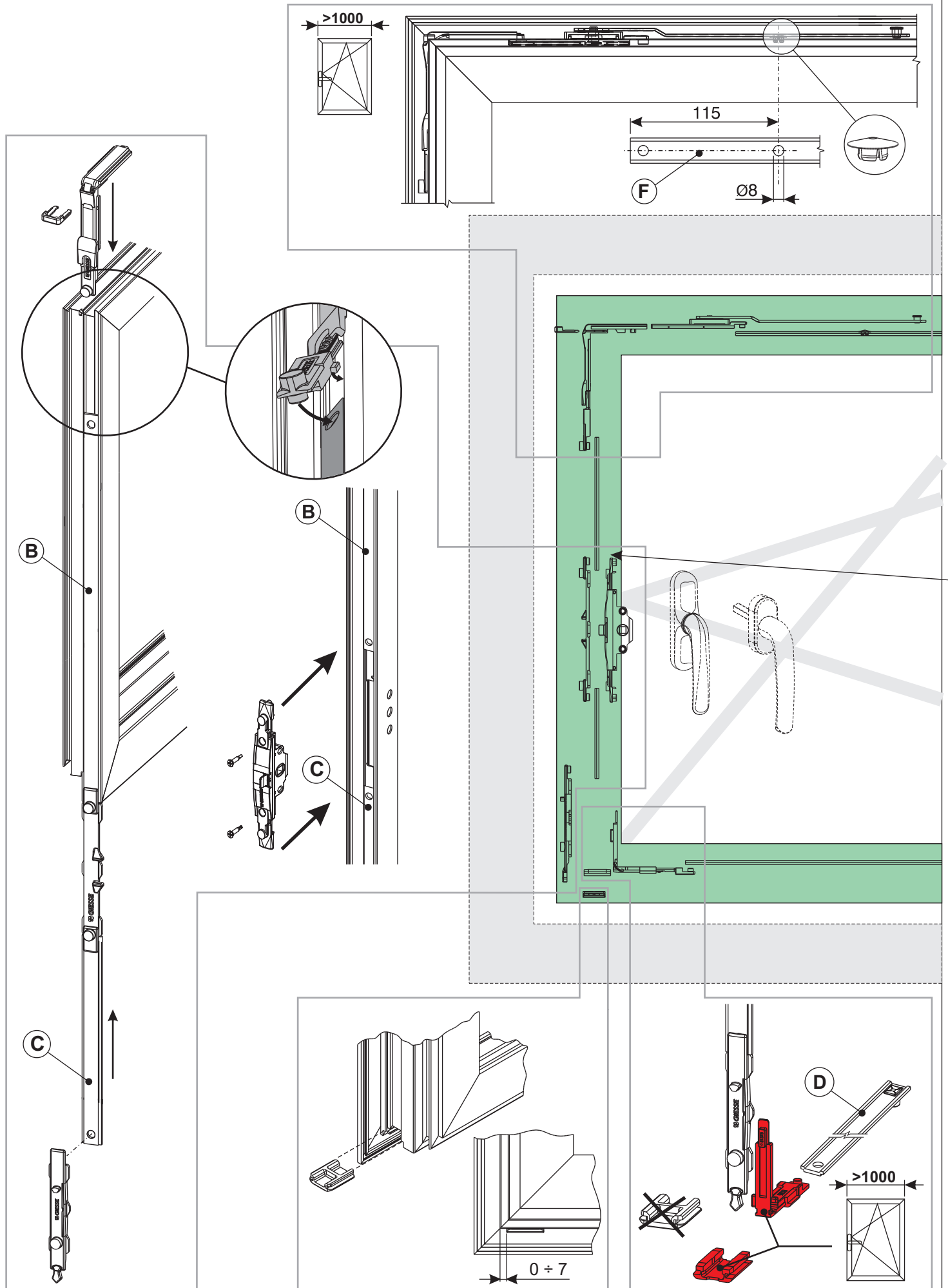

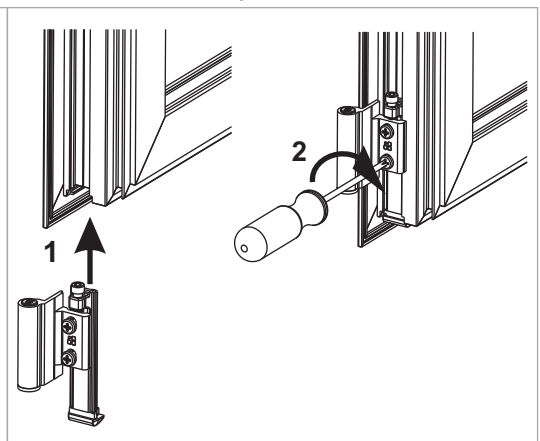
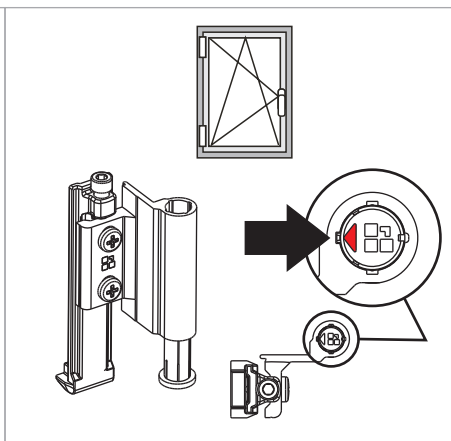
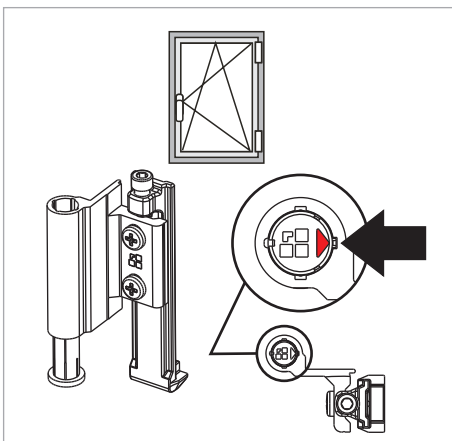
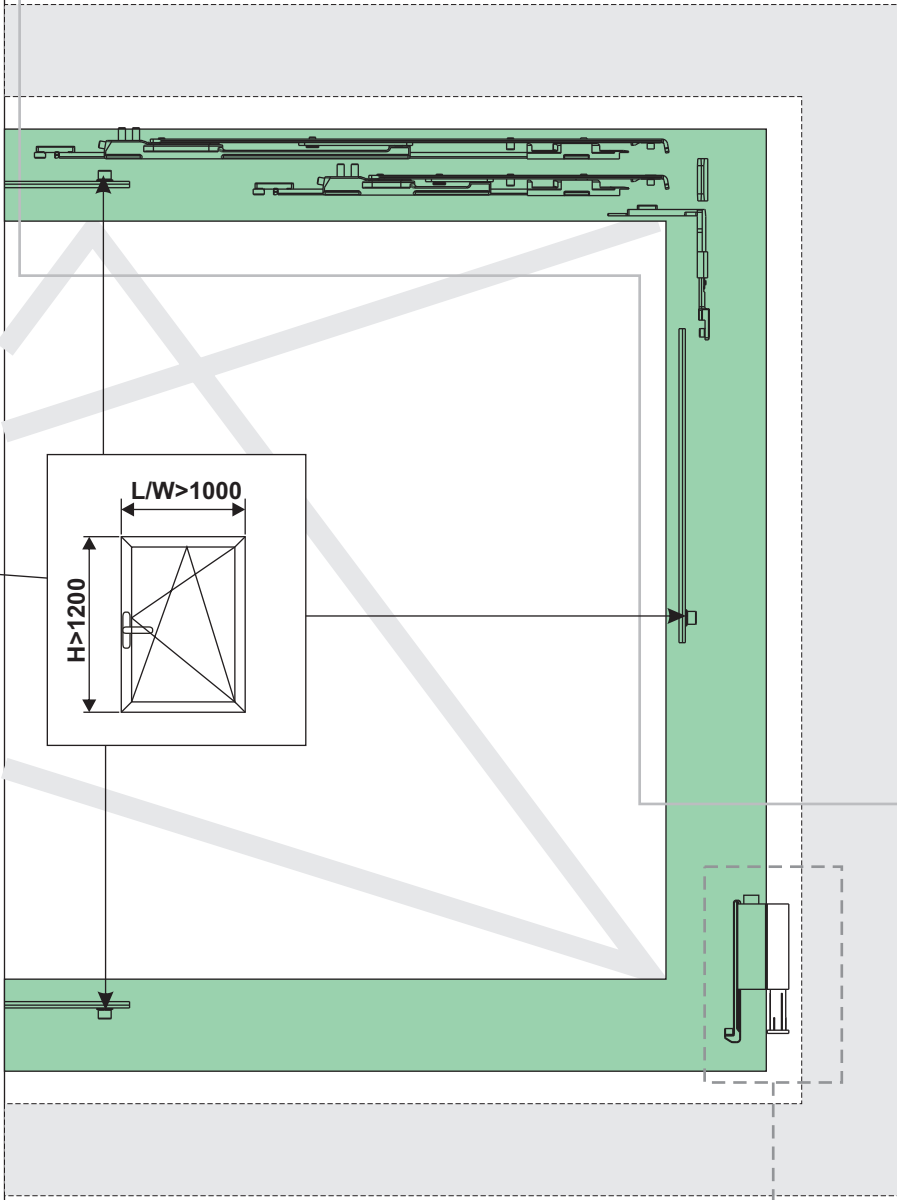
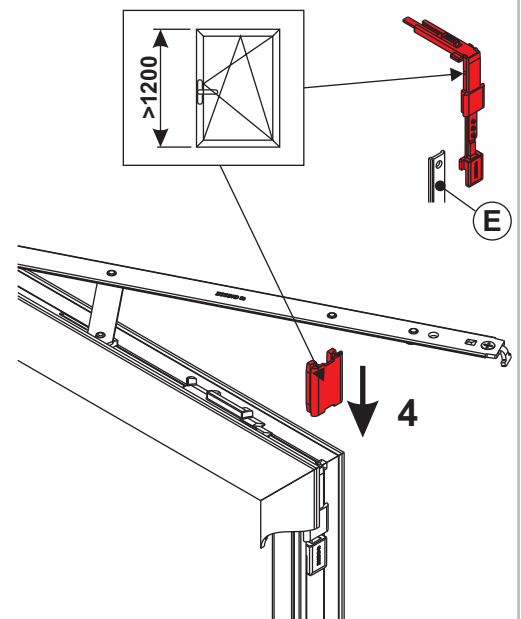
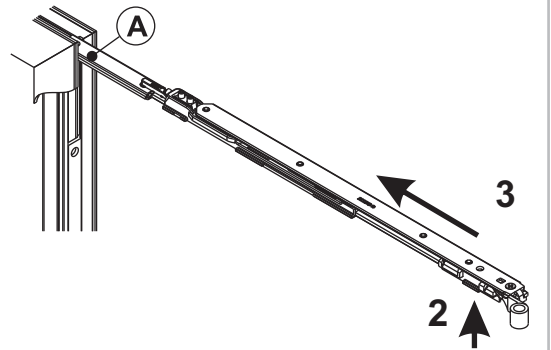
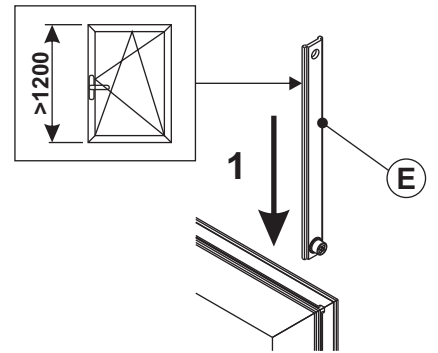
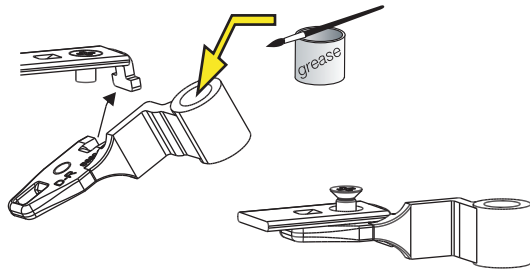
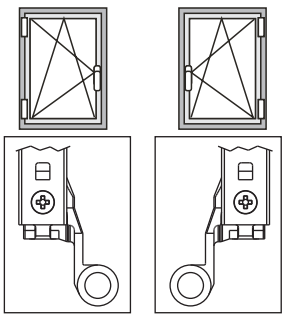

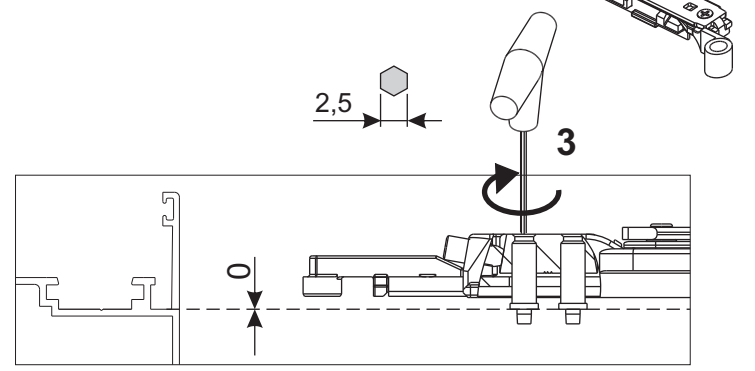
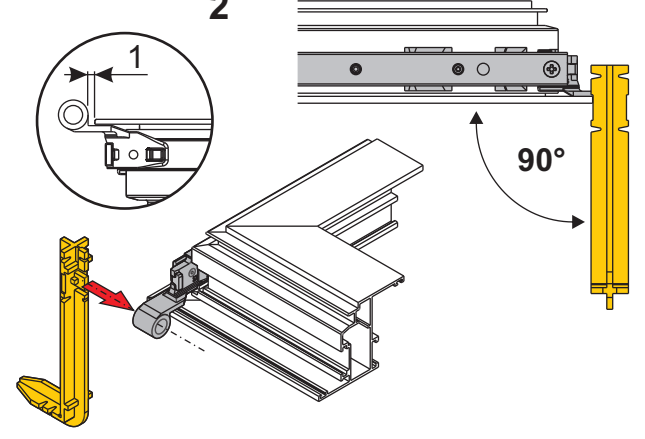
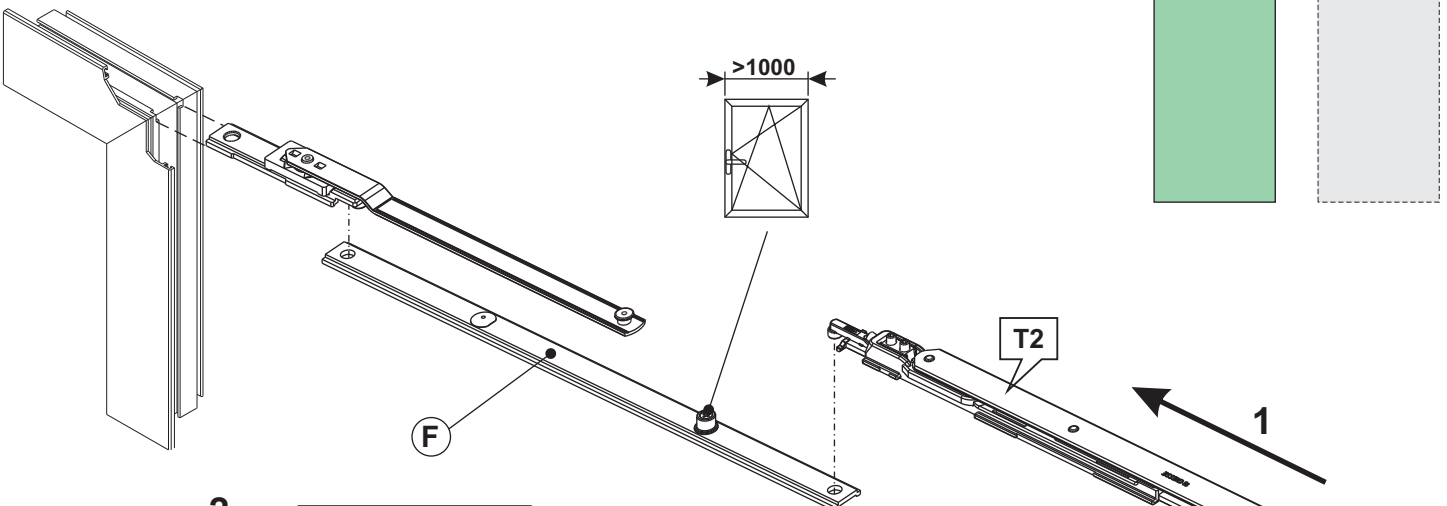
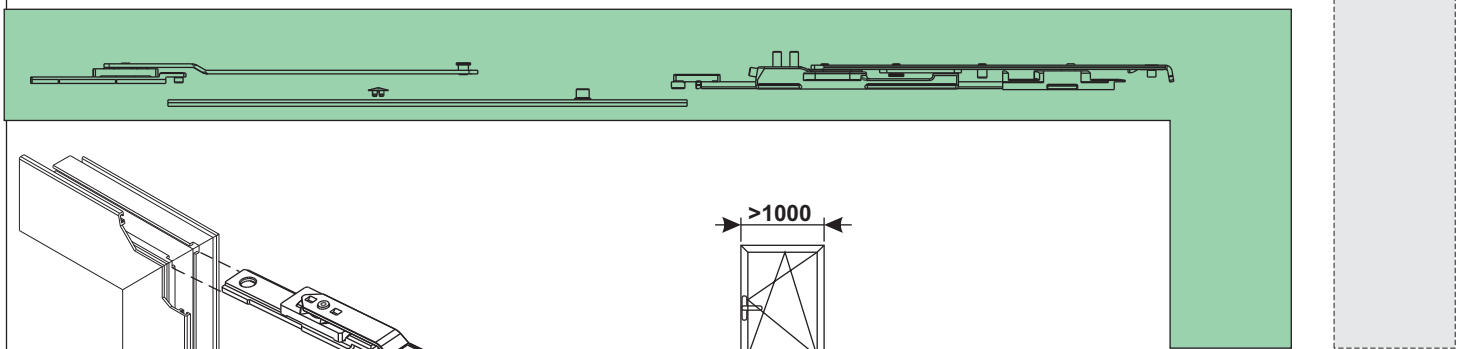
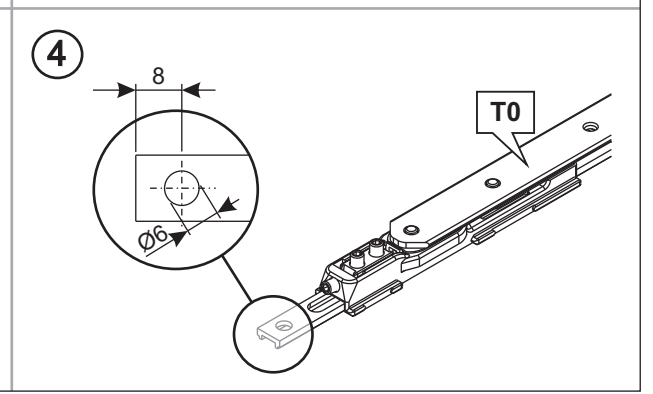
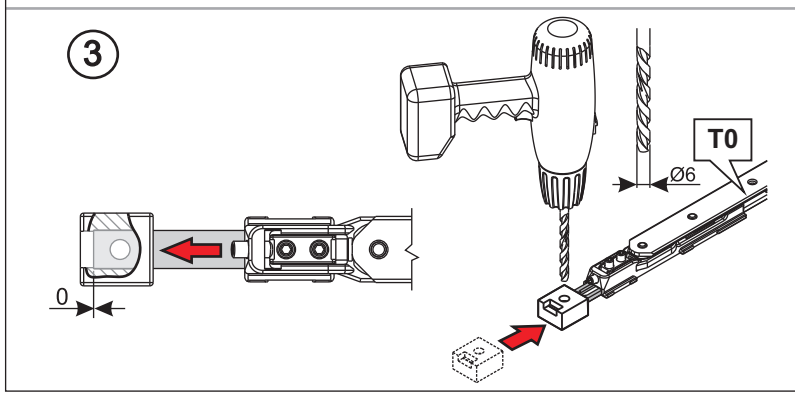
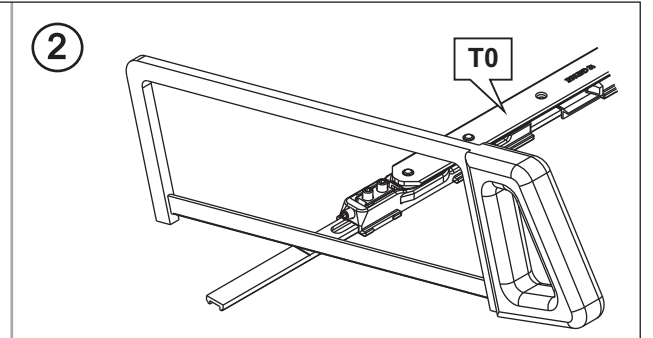
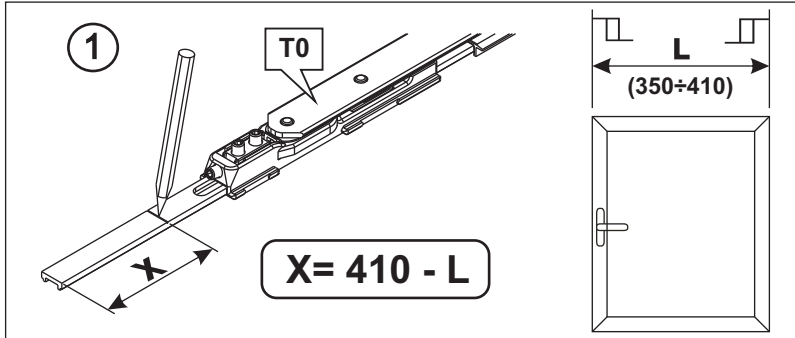

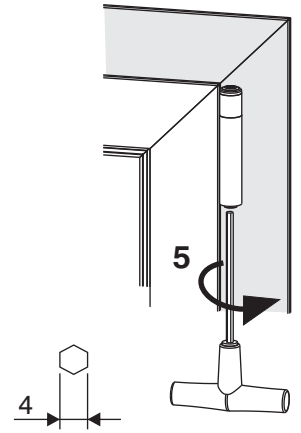
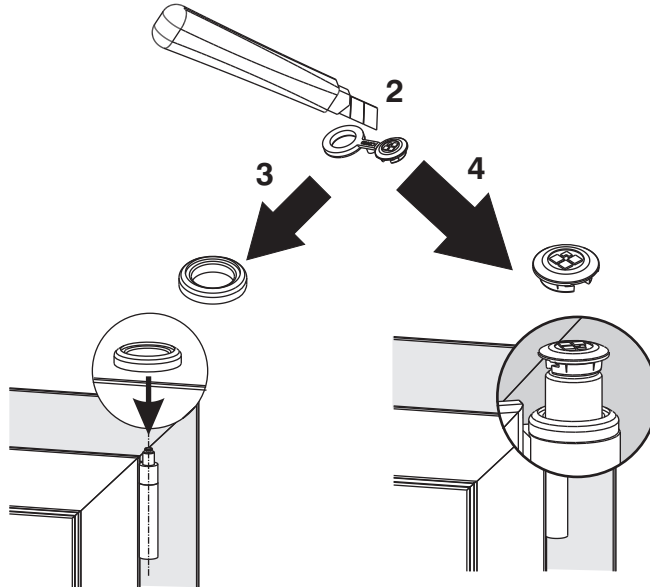
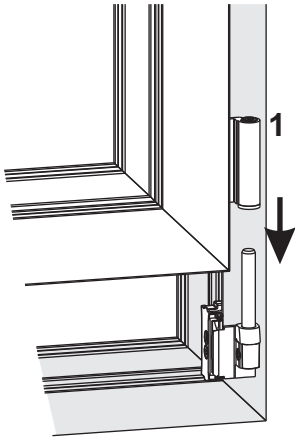
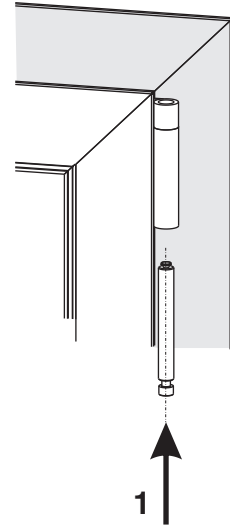
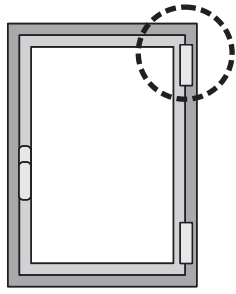
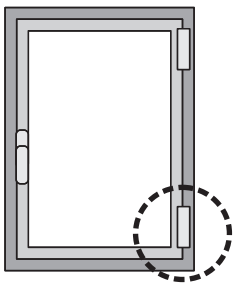

FUTURA 3D

130 micro

***** Quote indicative da verificare sull'anta installata e regolata con cremonese in posizione microventilazione
 Indicative distance to be checked on the leaf installed and adjusted in position with microventilation cremone

Cotas indicativas para el control de la hoja ensamblada y regulación cremona en posición de microventilación
 Die Maße sind zu überprüfen auf den montierten Flügel, und reguliert mit dem Griff bei der Mikrobelüftung Position

Η απόσταση τοποθέτησης είναι ενδεικτική. Ελέγξτε αφού πρώτα τοποθετήσετε το φύλλο και βάλετε την σπανιολέτα στην θέση μικρο-εξαερισμού.
 Cotes à vérifier sur l'ouvrant installé et réglé avec la crémone en position micro-ventilation

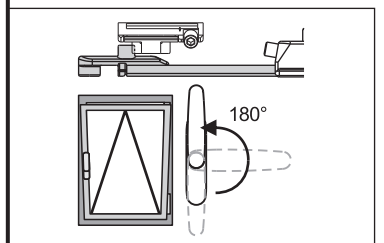
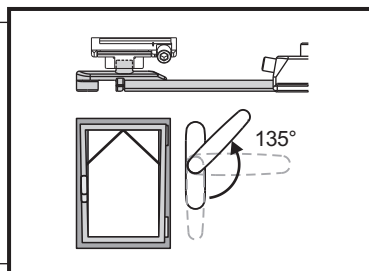
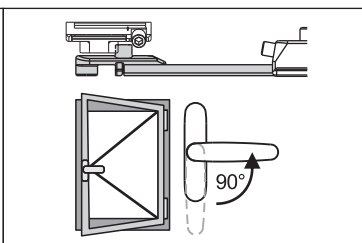
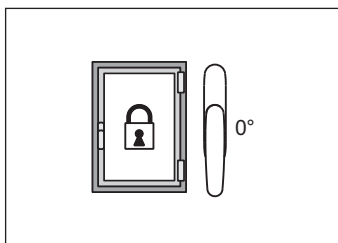
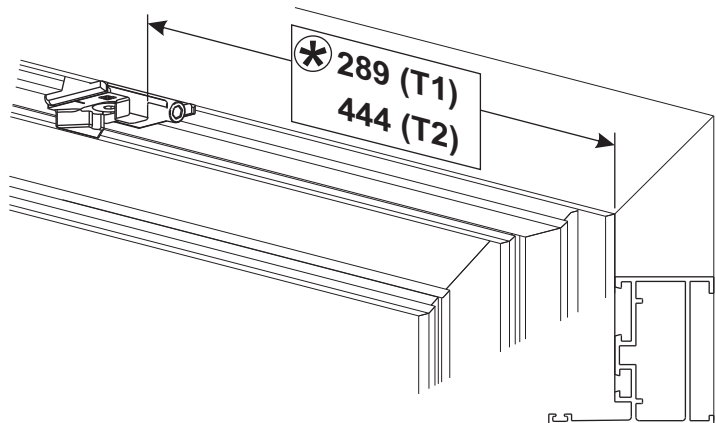
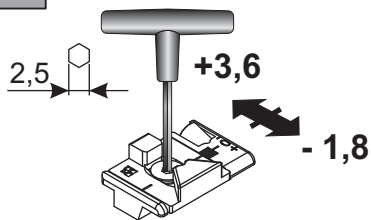
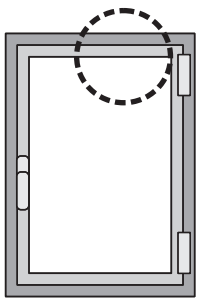

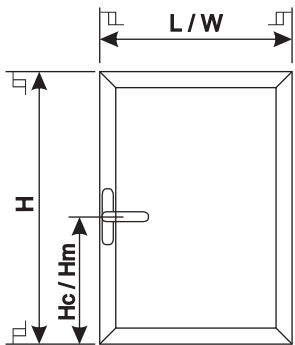
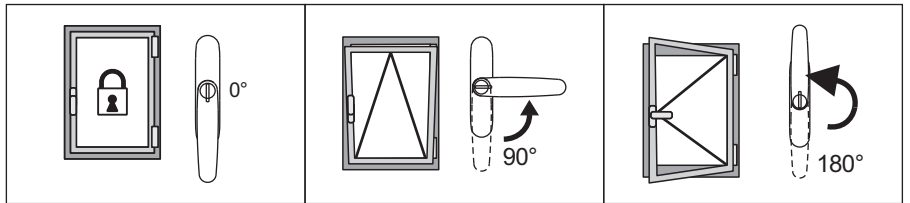
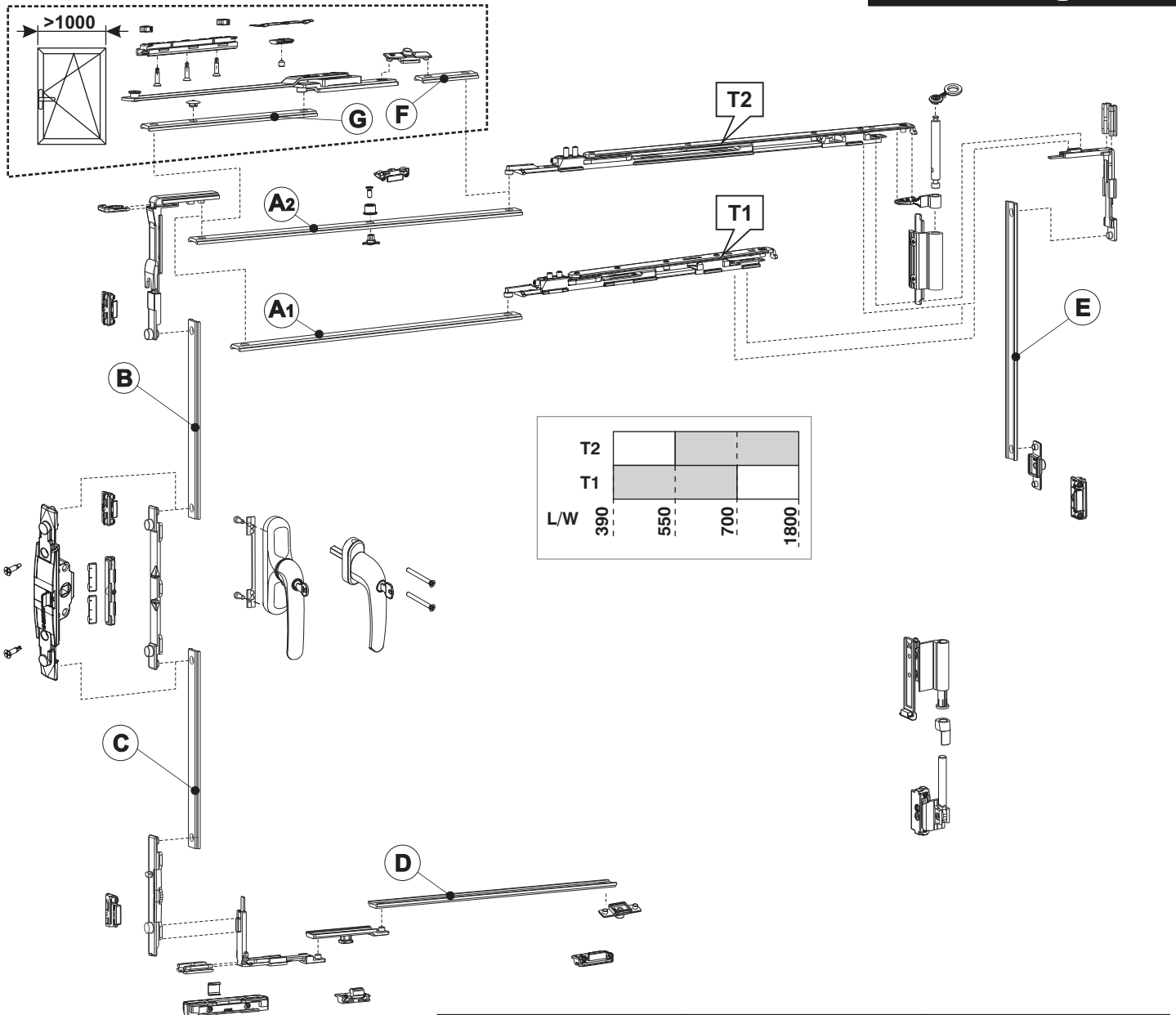

Hm/Hc ≥ 250

3000	A1	A1=L-355 B=H-Hc-207 C=Hc-207 E=H/2-69	A2	A2=L-510 B=H-Hc-207 C=Hc-207 E=H/2-69	G F	F=L-896 B=H-Hc-207 C=Hc-207 D=L/2-69 E=H/2-69 G=268
	B E		B E		B E	
1200	A1	A1=L-355 B=H-Hc-207 C=Hc-207	A2	A2=L-510 B=H-Hc-207 C=Hc-207	G F	F=L-896 B=H-Hc-207 C=Hc-207 D=L/2-69 G=268
600	B C		B C		B C	
	390	T1	700	550	T2	1000
						1001
						T2
						1800

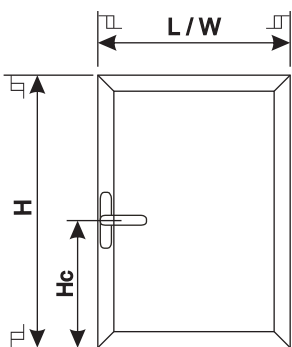
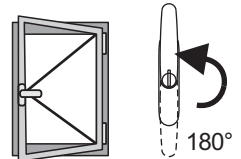
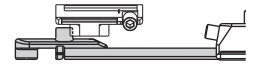
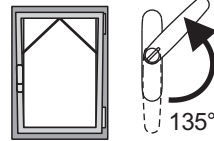
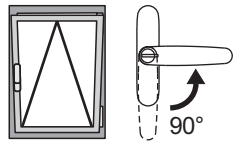
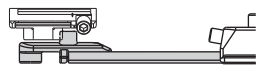
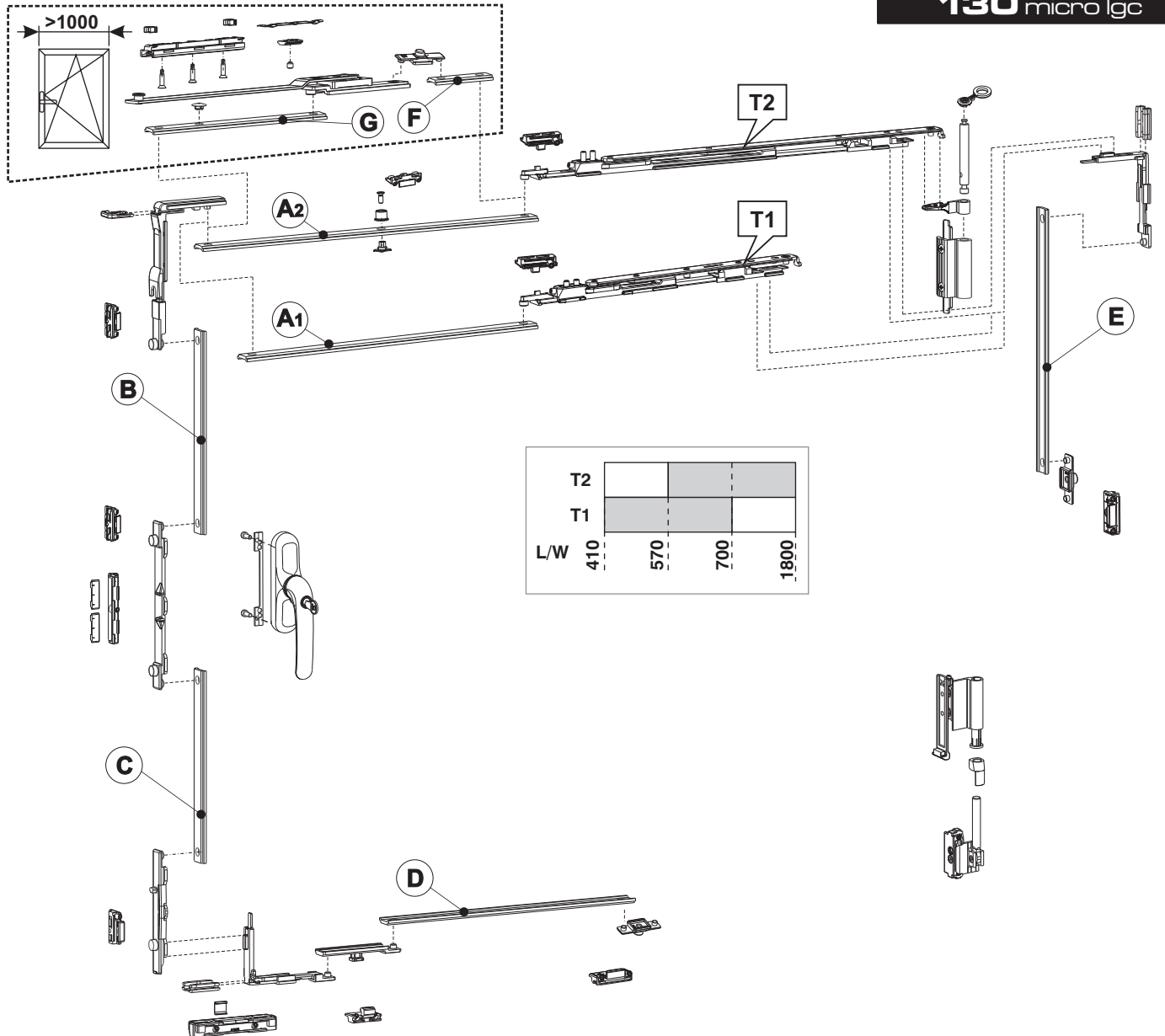

Hc ≥ 250

3000	A1	A1=L-355 B=H-Hc-207 C=Hc-207 E=H/2-69	A2	A2=L-510 B=H-Hc-207 C=Hc-207 E=H/2-69	G F	F=L-896 B=H-Hc-207 C=Hc-207 D=L/2-69 E=H/2-69 G=268
	B	E	B	E	B	E
1200	A1	A1=L-355 B=H-Hc-207 C=Hc-207	A2	A2=L-510 B=H-Hc-207 C=Hc-207	G F	F=L-896 B=H-Hc-207 C=Hc-207 D=L/2-69 G=268
	B	C	B	C	B	C
600					D	D
	410	T1	700	570	T2	1000
						1001
						T2
						1800

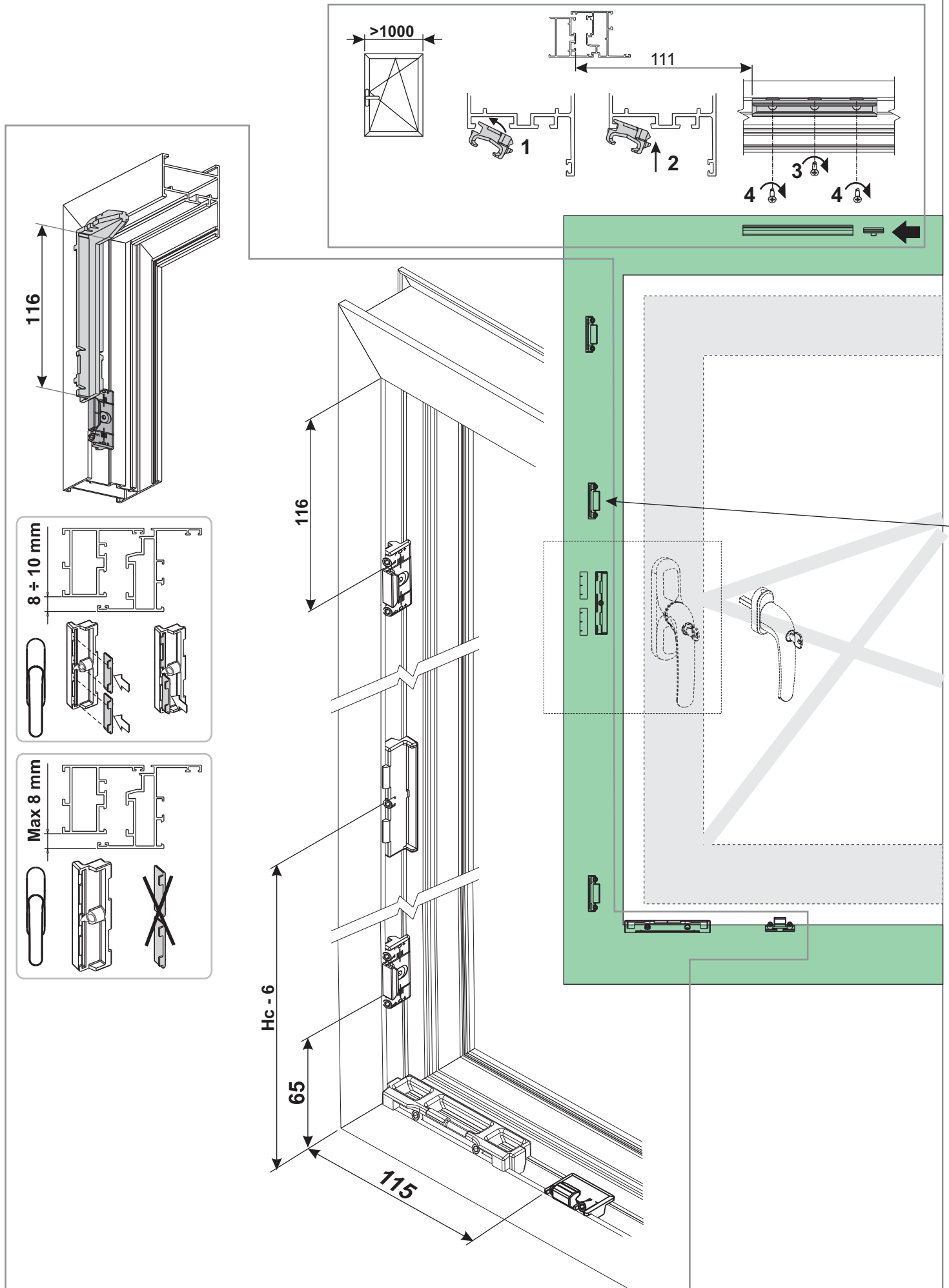

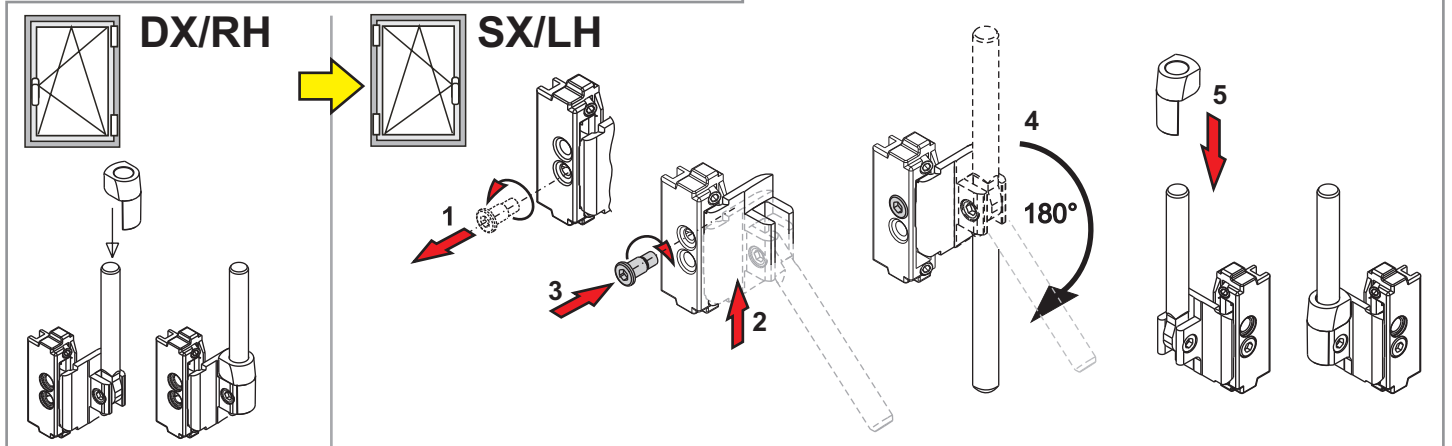
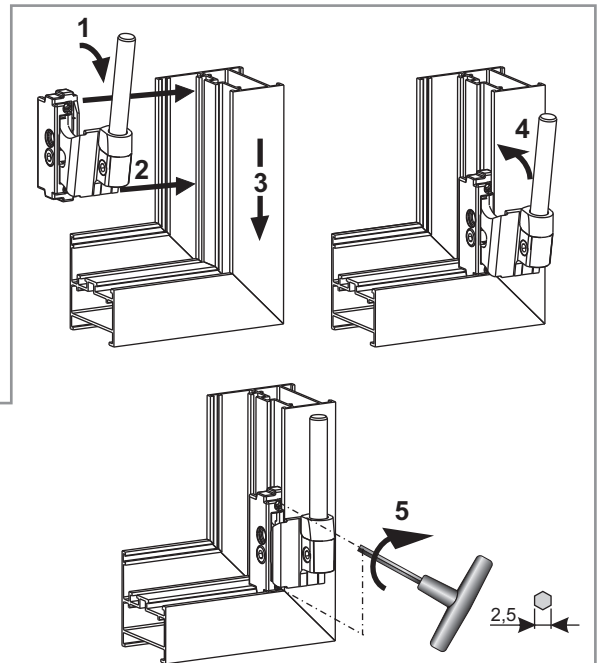
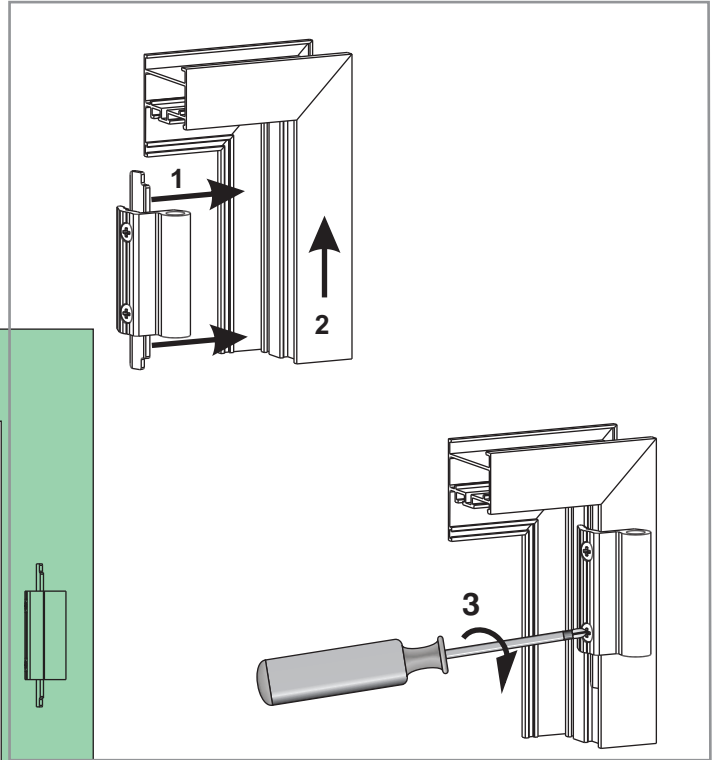
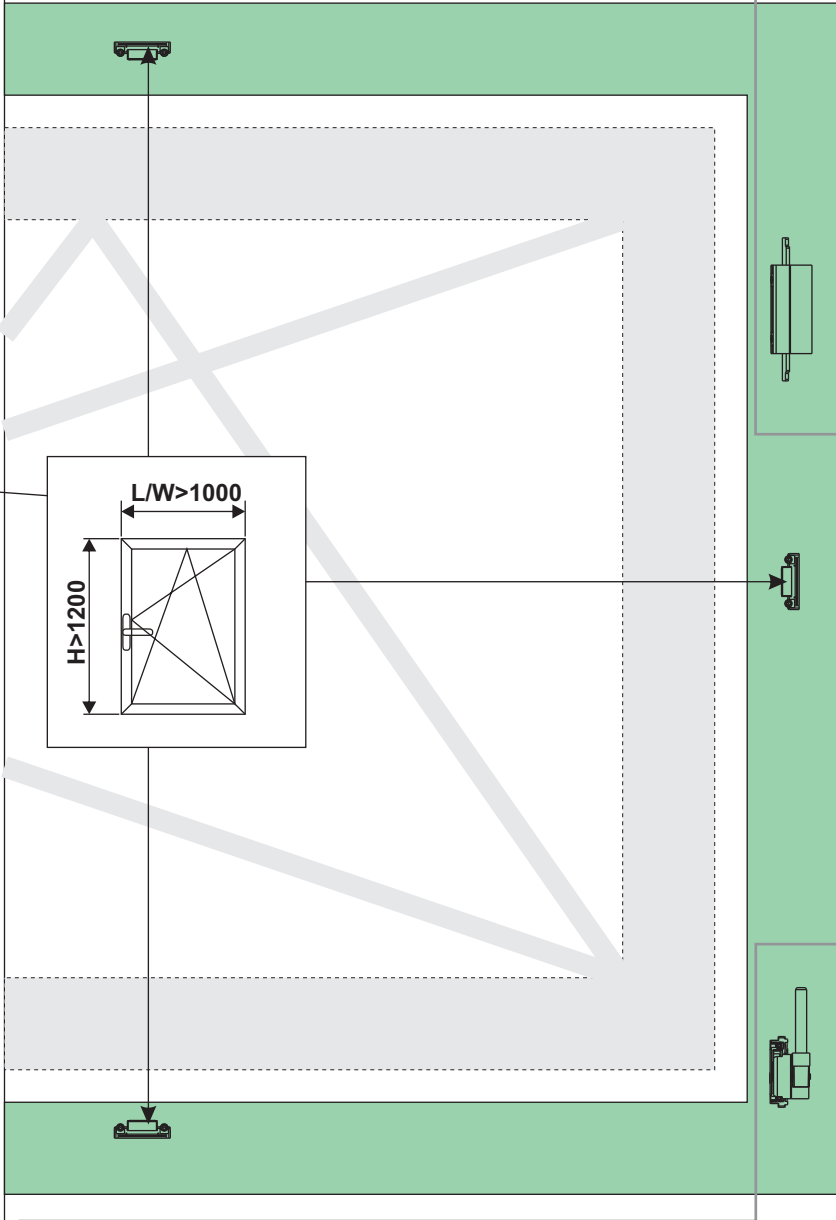

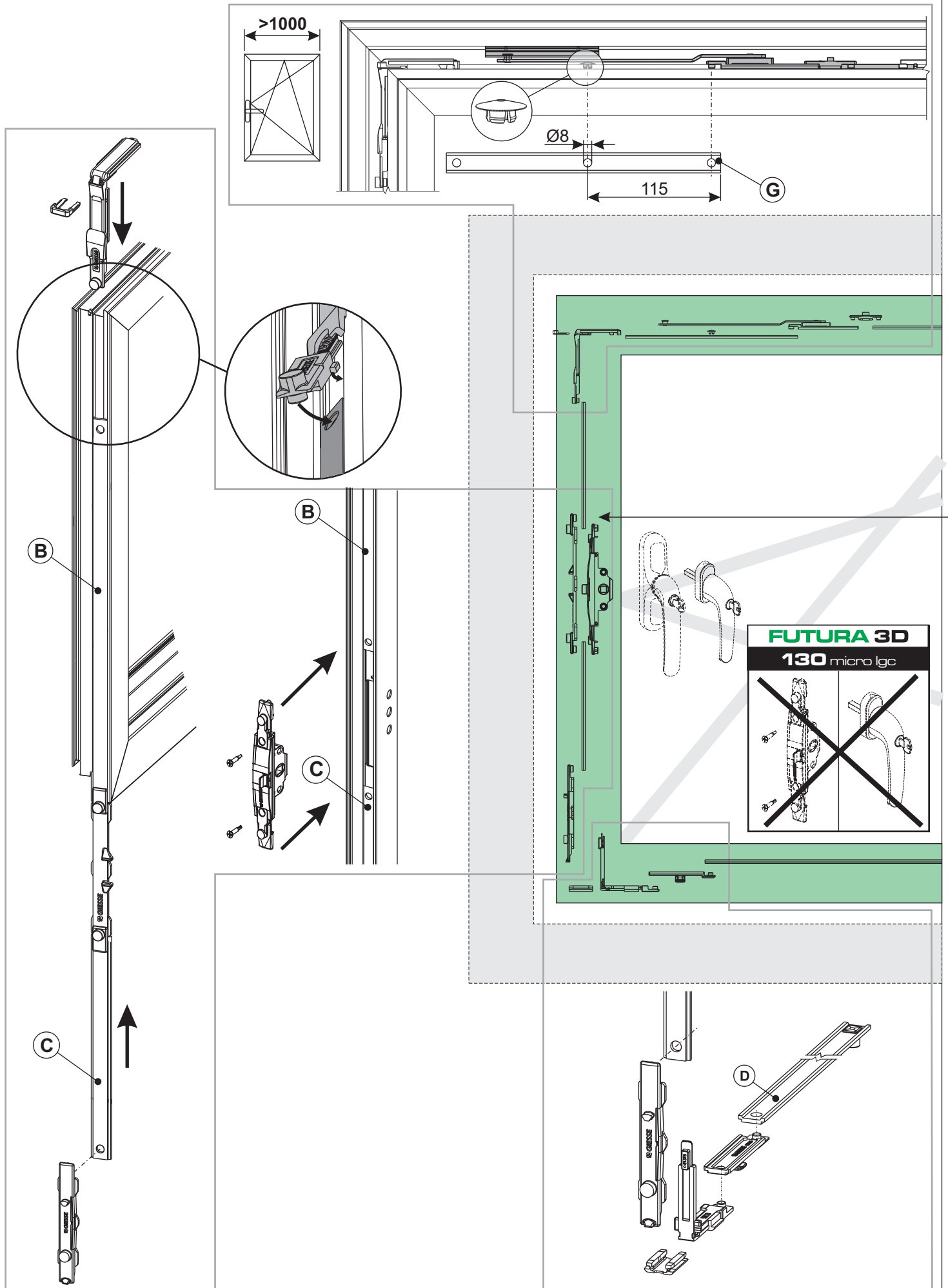

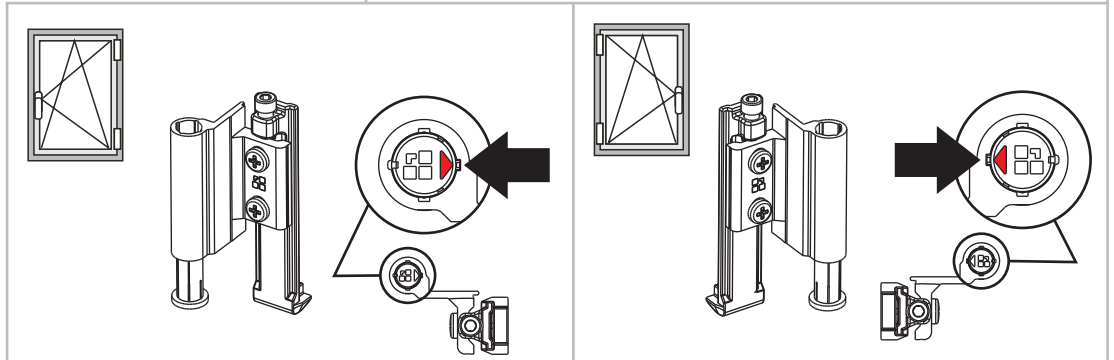
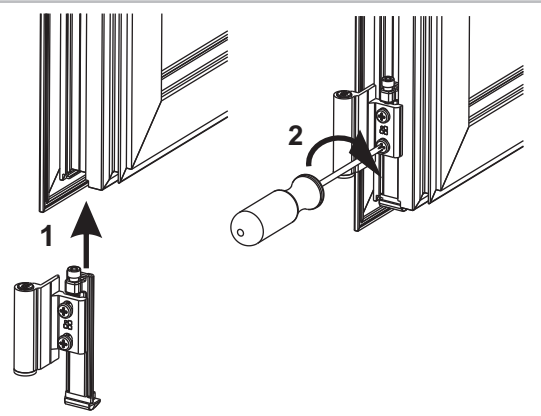
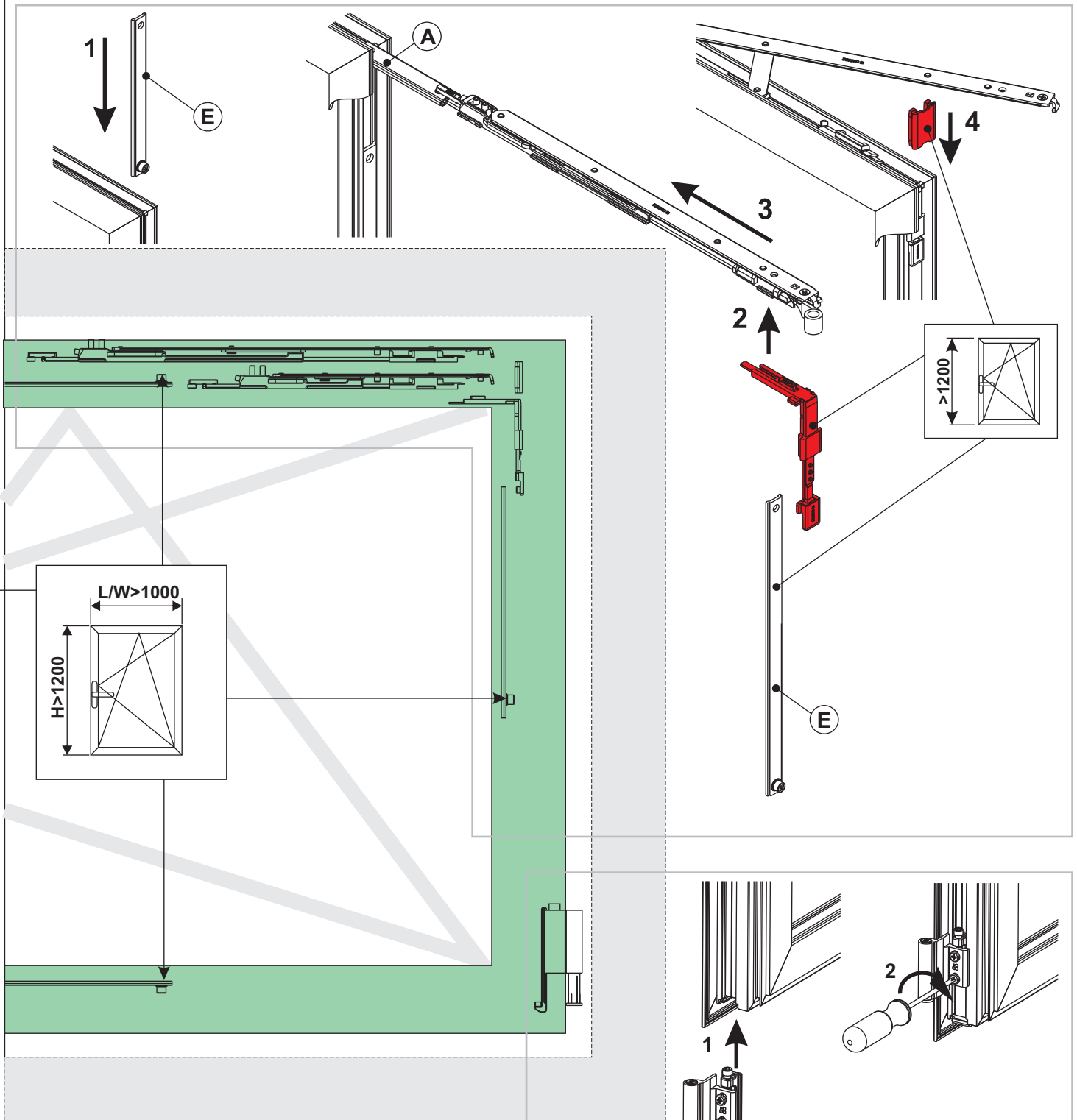

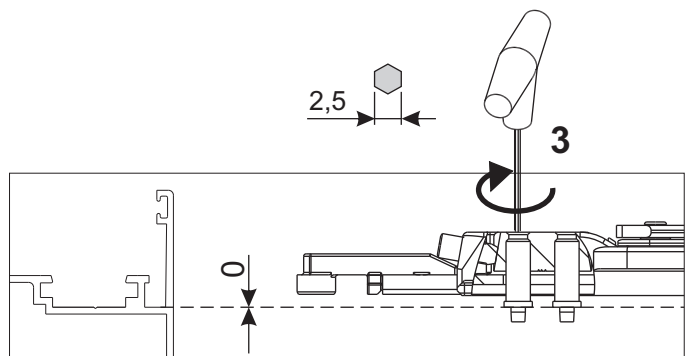
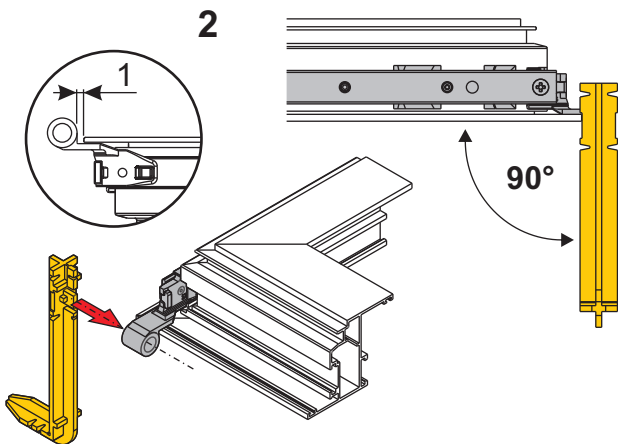
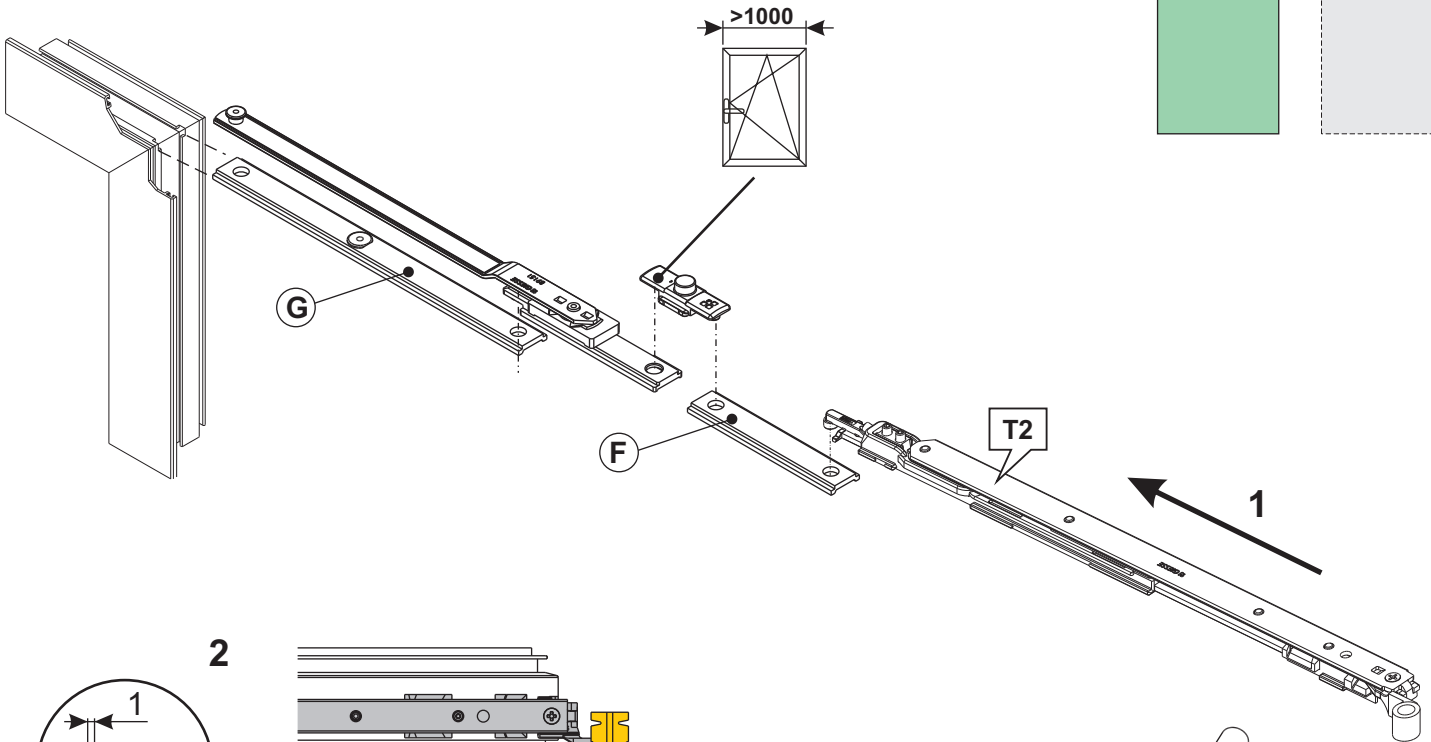
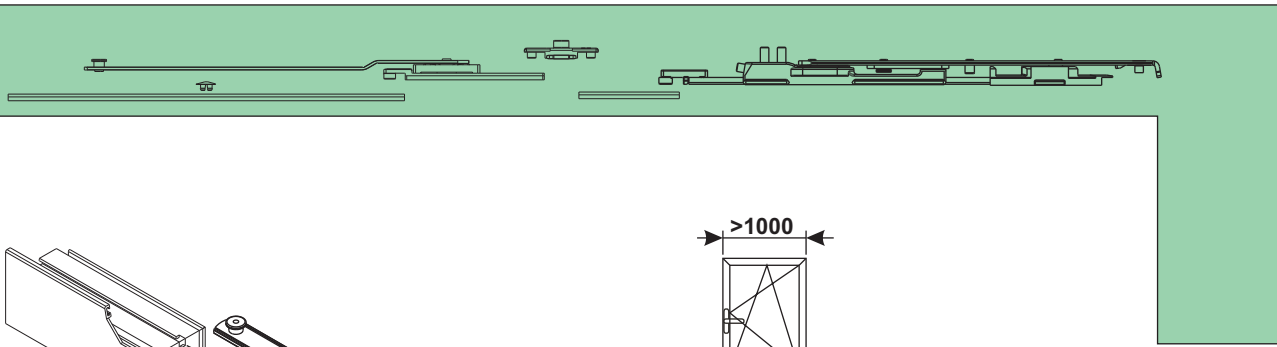
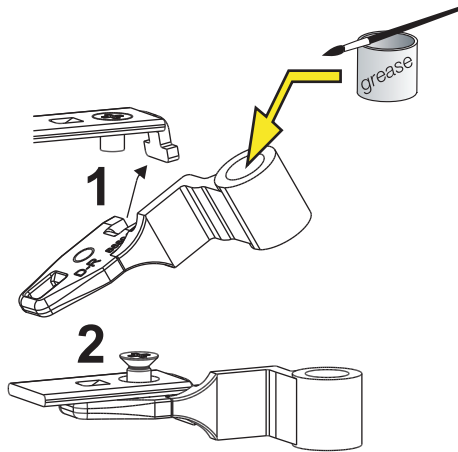
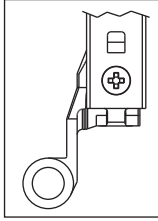
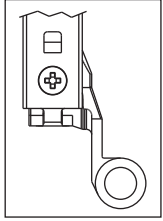
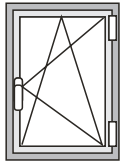
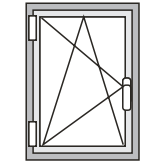

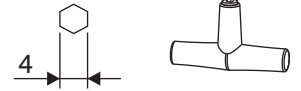
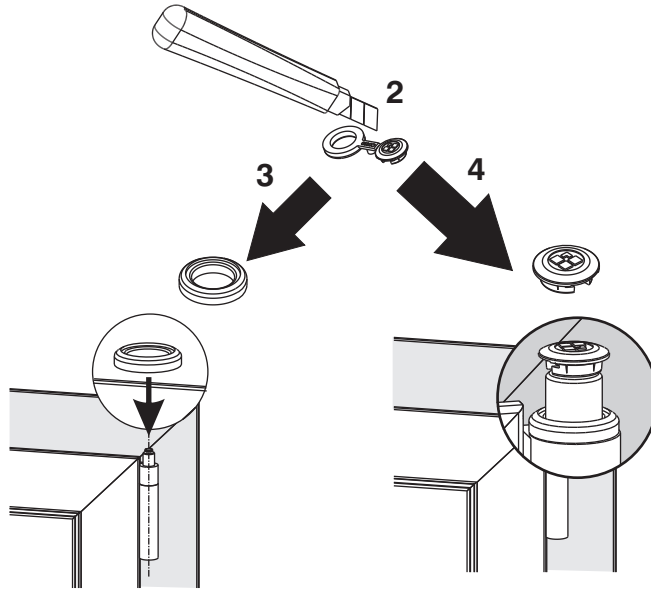
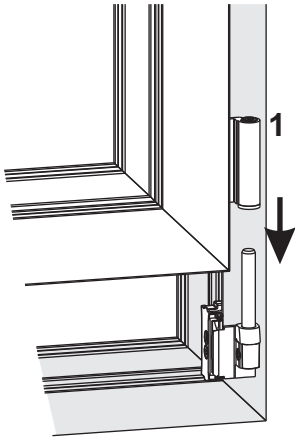
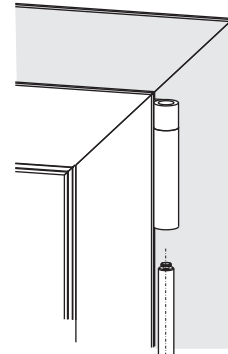
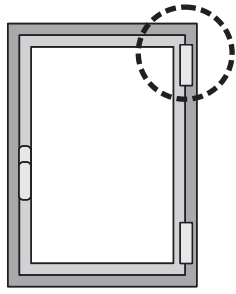
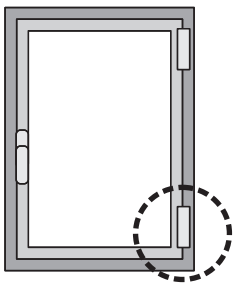

FUTURA 3D
130 micro Igc

***** Quote indicative da verificare sull'anta installata e regolata con cremonese in posizione microventilazione
 Indicative distance to be checked on the leaf installed and adjusted in position with microventilation cremone

Cotas indicativas para el control de la hoja ensamblada y regulación cremona en posición de microventilación
 Die Maße sind zu überprüfen auf den montierten Flügel, und reguliert mit dem Griff bei der Mikrobelüftung Position

Η απόσταση τοποθέτησης είναι ενδεικτική. Ελέγξτε αφού πρώτα τοποθετήσετε το φύλλο και βάλετε την σπανιολέτα στην θέση μικρο-εξαερισμού.
 Cotes à vérifier sur l'ouvrant installé et réglé avec la crémonne en position micro-ventilation

