

108210020CN/07-2022

Dimensioni e Portate realizzabili - Dimensiones y Capacidades admitidas - Διαστάσεις και Βάρη πραγματοποιήσιμα - Possible Dimensions and Capacities - Zulässige Abmessungen und Gewichte - Dimensions et charges possibles - Возможные размеры и грузоподъемность

ATTENZIONE: Le portate e il perfetto funzionamento dell'accessorio vengono garantiti solo se non vi sono impedimenti nella movimentazione dell'anta che forzano in modo anomalo le cerniere (ad esempio spallature, tappi od altri elementi di arresto).
ISTRUZIONI RIFERITE ALLA VERSIONE DESTRA.
In questo caso è obbligatorio l'utilizzo di un braccio limitatore FRIZ (L > 650 / 765 LGC).

ATENCIÓN: Las capacidades y el perfecto funcionamiento del accesorio están garantizados si no hay obstáculos en el movimiento de la hoja que fuercen de modo anómalo las bisagras (por ejemplo elementos de apoyo, capuchones u otros elementos de parada).
INSTRUCCIONES PARA ABERTURA MANO DERECHA.
En este caso es obligatorio utilizar el brazo limitador FRIZ (L > 650 / 765 LGC).

ΠΡΟΣΟΧΗ: Εγγυόμαστε για το βάρος του κουφώματος όταν δεν υπάρχουν εμπόδια κατά το άνοιγμα που εμποδίζουν τη σωστή λειτουργία των μεντεσέδων.
ΟΙ ΟΔΗΓΙΕΣ ΑΝΑΦΕΡΟΝΤΑΙ ΣΕ ΕΚΔΟΣΗ ΜΕ

ΑΝΟΙΓΜΑ ΔΕΞΙΟ.
Σ' αυτή την περίπτωση είναι υποχρεωτική η χρήση του κουμπιάσου φρένο (L > 650 / 765 LGC).

CAUTION: The capacities and correct functioning of the accessory are only guaranteed if there are no obstacles preventing movement of the wing which force the hinges excessively (such as protrusions, stoppers or other stop elements).
THE INSTRUCTIONS FOR RIGHT HAND FITTING
In such cases, you MUST use a FRIZ limiter arm (L > 650 / 765 LGC).

ACHTUNG: Die Tragfähigkeit und einwandfreie Funktion des Beschlages sind nur dann gewährleistet, wenn die Flügelbewegung ungehindert, d.h. ohne übermäßige Beanspruchung der Bänder, erfolgt (z.B. durch Absätze, Kappen oder andere Hindernisse).
DIE HINWEISE BEZIEHEN SICH AUF DIE VERSION RECHTS OEFFNUNG.
In diesem Fall muss die Begrenzungsschere FRIZ verwendet werden (L > 650 / 765 LGC).

ATTENTION: Les charges et le fonctionnement sont garantis si rien n'entrave le mouvement du vantail en soumettant les charnières à un effort anormal (par exemple, saillies, tampons ou autres dispositifs d'arrêt).
LES INSTRUCTIONS CONCERNENT LA VERSION OUVERTURE DROITE.
Dans ce cas, il est obligatoire d'utiliser le bras limiteur FRIZ (L > 650 / 765 LGC).

ВНИМАНИЕ: грузоподъемность и работа принадлежности гарантируется только при условии отсутствия препятствий для движения створки, создающих неправильное напряжение шарнирных петель (например, буртики, заглушки или другие стопорные детали).
ИНСТРУКЦИИ ПО МОДЕЛИ С ПРАВОСТОРОННИМ РАСКРЫТИЕМ
В данном случае необходимо использовать ограничительный кронштейн FRIZ (L > 650 / 765 LGC).

Spessore massimo del vetro impiegabile (senza camera d'aria) [mm] - Espesor máximo del cristal que se puede utilizar (sin cámara de aire) [mm] - Μέγιστη απόσταση τζαμιών (χωρίς το κενό) [mm] - Maximum possible thickness of glass (without air space) [mm] - Max. zulässige Glasstärke (ohne Luftzwischenraum) [mm] - Épaisseur maximale utilisable pour le vitrage (sans lame d'air) [mm] - Максимальная толщина используемого стекла (без воздушной камеры) [mm]

Altezza anta (mm) - Altura hoja (mm) Ύψος Φύλλου (mm) Wing height (mm) - Flügelhöhe (mm) Hauteur vantail (mm) - Высота створки (мм)	2800	40	33	29	25	22	20	18	17	15	14		
	2700	42	35	30	26	23	21	19	18	16	15		
	2600	45	37	32	28	25	22	20	19	17	16	15	
	2500	49	41	35	31	27	25	22	20	19	18	16	15
	2400	49	41	35	31	27	25	22	20	19	18	16	15
	2300	51	43	37	32	28	26	23	21	20	18	17	16
	2200	54	45	38	33	30	27	24	22	21	19	18	17
	2100	56	47	40	35	31	28	25	23	22	20	19	18
	2000	59	49	42	37	33	29	27	25	23	21	20	18
	1900	60	52	44	39	34	31	28	26	24	22	21	19
	1800	60	55	47	41	36	33	30	27	25	23	22	20
	1700	60	58	49	43	38	35	31	29	27	25	23	20
	1600	60	60	53	46	41	37	33	31	28	26	23	20
	1500	60	60	56	49	44	39	36	33	30	26	23	20
	1400	60	60	60	53	47	42	38	35	30	26	23	20
	1300	60	60	60	57	50	45	41	35	30	26	23	20
	1200	60	60	60	60	55	49	42	35	30	26	23	
1100	60	60	60	60	59	51	42	35	30	26			
1000	60	60	60	60	60	51	42	35	30				
900	60	60	60	60	60	51	42	35					
800	60	60	60	60	60	51	42						
700	60	60	60	60	60	51							
600	50	50	50	50	50	51							
470	500	600	700	800	900	1000	1100	1200	1300	1400	1500	1600	

Larghezza anta (mm) - Anchura hoja (mm) - Πλάτος Φύλλου (mm) - Wing width (mm) - Flügelbreite (mm) - Largeur vantail (mm) - Ширина створки (мм)

Non realizzabile
No puede realizarse
Μη πραγματοποιήσιμα
Not possible
Nicht möglich
Irréalizable
Не может быть выполнено

Peso massimo dell'anta (alluminio e vetro) [kg] - Peso máximo de la hoja (aluminio y cristal) [kg] - Μέγιστο βάρος Φύλλου (Αλουμίνιο & Τζάμι) [kg] - Maximum wing weight (aluminium and glass) [kg] - Max. Flügelgewicht (Aluminium und Glas) [kg] - Poids maximum du vantail (aluminium et vitrage) [kg] - Максимальный вес створки (алюминий и стекло) [kg]

Altezza anta (mm) - Altura hoja (mm) Ύψος Φύλλου (mm) Wing height (mm) - Flügelhöhe (mm) Hauteur vantail (mm) - Высота створки (мм)	2800	143	143	143	143	143	143	143	143	143			
	2700	145	145	145	145	145	145	145	145	145			
	2600	148	148	148	148	148	148	148	148	148	148		
	2500	150	150	150	150	150	150	150	150	150	150	150	
	2400	150	150	150	150	150	150	150	150	150	150	150	
	2300	150	150	150	150	150	150	150	150	150	150	150	
	2200	150	150	150	150	150	150	150	150	150	150	150	
	2100	150	150	150	150	150	150	150	150	150	150	150	
	2000	150	150	150	150	150	150	150	150	150	150	150	
	1900	150	150	150	150	150	150	150	150	150	150	150	
	1800	150	150	150	150	150	150	150	150	150	150	146	
	1700	150	150	150	150	150	150	150	150	150	147	138	
	1600	150	150	150	150	150	150	150	150	148	138	130	
	1500	150	150	150	150	150	150	150	150	148	139	130	122
	1400	150	150	150	150	150	150	150	150	140	130	121	113
	1300	150	150	150	150	150	150	150	140	130	120	112	105
	1200	150	150	150	150	150	150	141	130	120	111	104	
1100	150	150	150	150	150	143	130	119	110	102			
1000	150	150	150	150	144	130	118	108	100				
900	150	150	150	146	130	117	106	97					
800	150	150	148	130	115	104	94						
700	150	150	130	113	101	91							
600	500	600	700	800	900	1000	1100	1200	1300	1400	1500	1600	

Larghezza anta (mm) - Anchura hoja (mm) - Πλάτος Φύλλου (mm) - Wing width (mm) - Flügelbreite (mm) - Largeur vantail (mm) - Ширина створки (мм)

Non realizzabile
No puede realizarse
Μη πραγματοποιήσιμα
Not possible
Nicht möglich
Irréalizable
Не может быть выполнено

Lubrificare con prodotti a base di vaselina sia le guide che tutti i meccanismi prima del loro inserimento. Impiegare astine di collegamento in poliammide o in alternativa in alluminio con trattamento di ossidazione e non di verniciatura.
Eseguire sull'anta mobile le lavorazioni indicate su questo documento.
Si garantisce il funzionamento dell'accessorio descritto in queste istruzioni solo se l'infisso è stato installato a regola d'arte, quindi in squadro e senza impedimenti nell'apertura totale dell'anta.
Nel caso in cui l'infisso richieda il braccio FRIZ: L > 650 mm (LGC L > 765 mm).

Lubricar con productos a base de vaselina tanto las guías como todos los mecanismos antes de introducirlos. Utilizar varillas de conexión de poliamida o en alternativa de aluminio con tratamiento de oxidación y sin pintura.
Realizar en la hoja móvil las preparaciones indicadas en este documento. Se garantiza el funcionamiento del accesorio descrito en estas instrucciones sólo si el bastidor se ha instalado correctamente, es decir, en escuadra y sin obstáculos en la apertura total de la hoja.
En el caso que la ventana requiera el brazo FRIZ: L > 650 mm (LGC L > 765 mm).

Λιπάνετε με προϊόντα που έχουν ως βάση την βαζελίνη, τους οδηγούς αλλά και όλους τους μηχανισμούς πριν την εισαγωγή τους.
Χρησιμοποιήστε ντίξες σύνδεσης πολυαμιδίου ή εναλλακτικά αλουμινίου με επεξεργασία ανοδίωσης και όχι με βαφή πούδρας.
Πραγματοποιήστε την κατεργασία στο φύλλο όπως παρουσιάζεται στο παρόν έγγραφο.
Εγγυόμαστε τη καλή λειτουργία του εξαρτήματος που περιγράφονται σε αυτές τις οδηγίες μόνο αν το κούφωμα είναι εγκατεστημένο με τον κατάλληλο τρόπο, δηλαδή ευθυγραμμισμένο και χωρίς εμπόδια στο σύνολο του ανοίγματος του φύλλου.

Στην περίπτωση κατά την οποία το κούφωμα απαιτεί τον βραχίονα FRIZ: L > 650 mm (LGC L > 765 mm).

Use vaseline-based products to lubricate both the guides and all the mechanisms before inserting them.
Use polyamide connecting rods or aluminium connecting rods which have been subject to oxidation treatment and not painted.
Carry out all the machining operations on the mobile wing indicated in this document.
Correct functioning of the accessory described in these instructions is only guaranteed if the window has been installed correctly, that is, flush and without obstacles preventing total wing opening.
If the window requires the FRIZ arm: L > 650 mm (LGC L > 765 mm).

Die Führungen und alle Getriebeteile vor dem Einbau mit Vaseline einfetten.
Polyamid-Verbindungsstangen oder Verbindungsstangen aus eloxiertem und unlackiertem Aluminium verwenden.
Am Flügel die in dieser Anleitung angegebenen Bearbeitungen ausführen.
Die einwandfreie Funktion des in dieser Anleitung beschriebenen Beschlags ist nur dann gewährleistet, wenn das Fenster sachgerecht montiert wurde, d.h. lotrecht und ohne Hindernisse bei der vollständigen Öffnung des Flügels.
Falls das Fenster eine Schere FRIZ erfordert: Länge L > 650 mm aufweist (LGC L > 765 mm).

Avant tout montage, lubrifier les guides et tous les mécanismes avec des produits à base de vaseline. Utiliser des tringles en polyamide ou en aluminium ayant subi un traitement contre

l'oxydation et non un vernissage.
Effectuer sur l'ouvrant les usinages indiqués dans le présent document.

Le bon fonctionnement de l'accessoire qui est décrit dans les présentes instructions est garanti uniquement si la fenêtre est montée dans les règles de l'art, c'est-à-dire à angle droit et sans que l'ouverture totale du vantail soit entravée.
Lorsque le bras FRIZ est nécessaire pour des châssis: la longueur doit être L > 650 mm (LGC L > 765 mm).

Прежде чем установить направляющие и механизмы, следует смазать их составами на основе вазелина. Используйте соединительные штанги из полиамида или, в качестве альтернативы, штанги из алюминия, подвергнутые оксидированию, но не окраске.
Выполните с подвижной створкой указанные в настоящем документе операции. Работа описанной в инструкциях принадлежности гарантируется только при условии безукоризненной ее установки, т.е. под прямым углом и без препятствий для полного раскрытия створки на.
В том случае, когда для установки переплета необходим кронштейн FRIZ: длина L > 650 mm (LGC L > 765 mm).

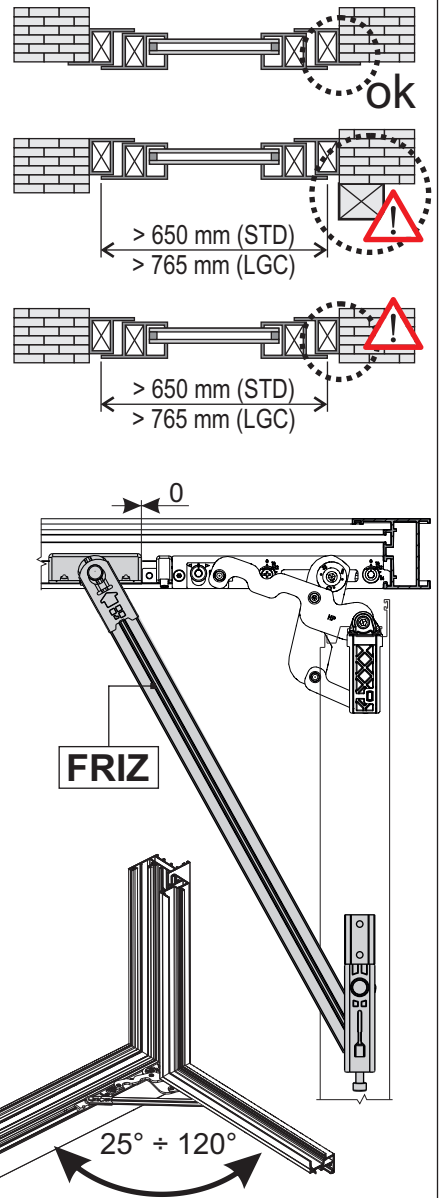

LAVORAZIONI PRELIMINARI SU ANTA MOBILE - OPERACIONES PRELIMINARES EN LA HOJA MÓVIL - ΠΡΟΕΡΓΑΣΙΕΣ ΣΤΟ ΦΥΛΛΟ
PRELIMINARY MOBILE WING MACHINING OPERATIONS - BEARBEITUNGEN AM FLÜGEL USINAGES
PRELIMINAIRES A PRATIQUER SUR L'OUVRANT - ПРЕДВАРИТЕЛЬНЫЕ ОПЕРАЦИИ НА ПОДВИЖНОЙ СТВОРКЕ

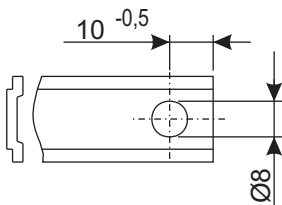
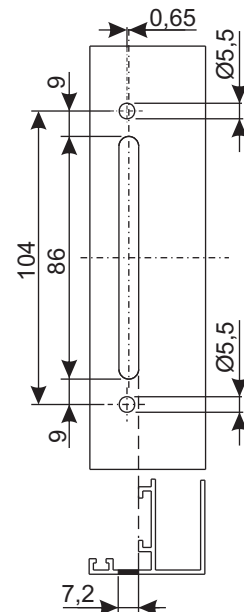
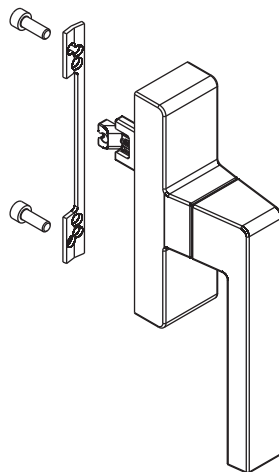
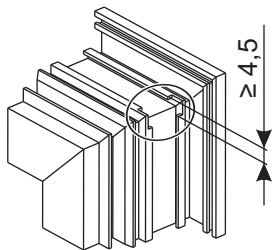

LAVORAZIONI PRELIMINARI SU ANTA MOBILE - OPERACIONES PRELIMINARES EN LA HOJA MÓVIL - ΠΡΟΕΡΓΑΣΙΕΣ ΣΤΟ ΦΥΛΛΟ
 PRELIMINARY MOBILE WING MACHINING OPERATIONS - BEARBEITUNGEN AM FLÜGEL USINAGES
 PRELIMINAIRES A PRATIQUER SUR L'OUVRANT - ПРЕДВАРИТЕЛЬНЫЕ ОПЕРАЦИИ НА ПОДВИЖНОЙ СТВОРКЕ

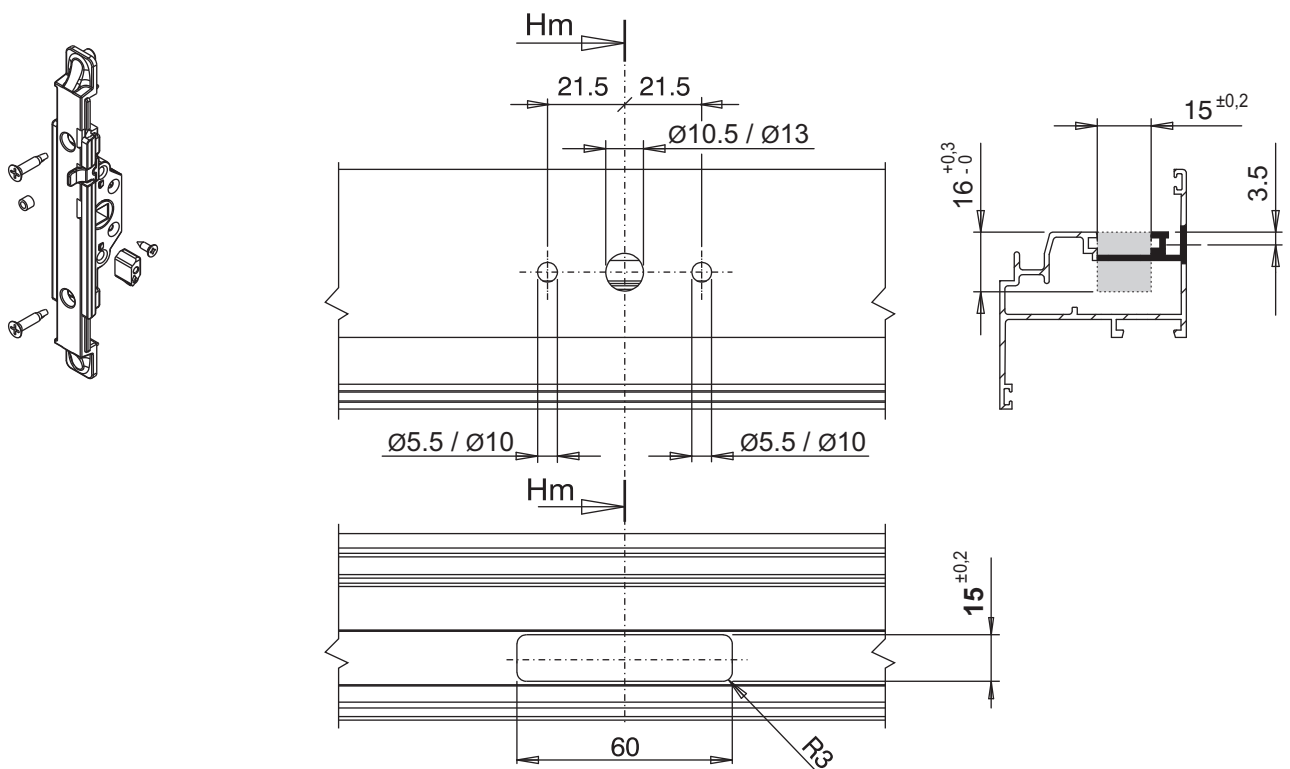
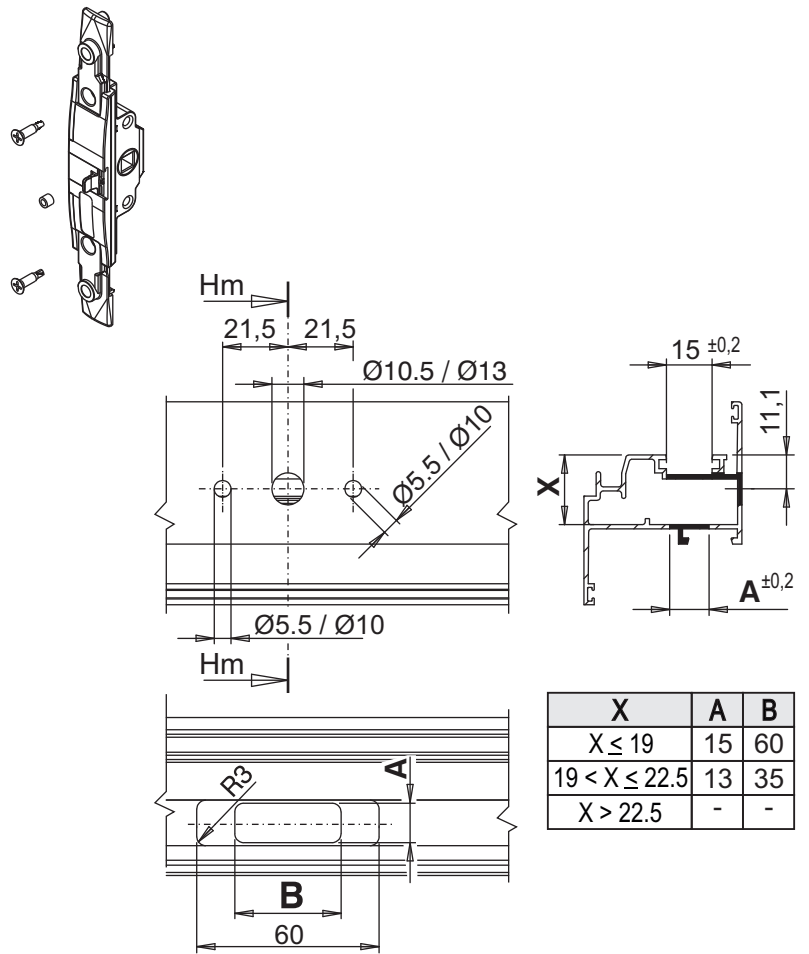
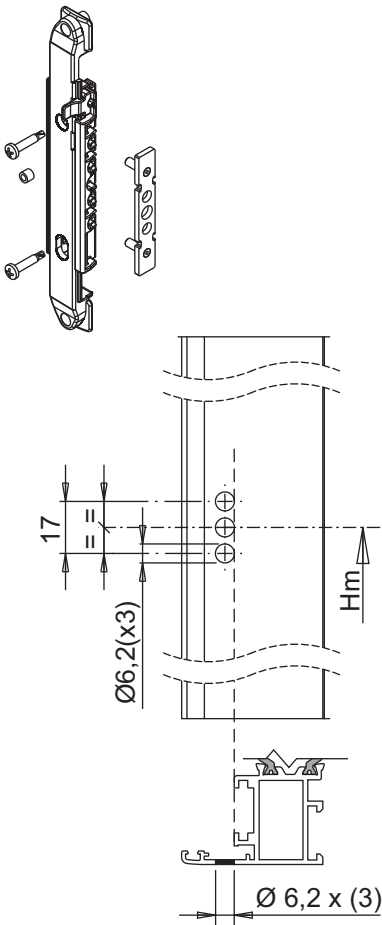

CALCOLO RELATIVO AL TAGLIO ASTE - CÁLCULO RELATIVO AL CORTE DE LAS VARILLAS
 ΥΠΟΛΟΓΙΣΜΟΣ ΚΟΠΗΣ ΛΑΜΑΚΙΩΝ - ROD CUTTING CALCULATIONS - BERECHNUNG DER STANGENLÄNGEN
 CALCUL RELATIF À LA COUPE DES TRINGLES - РАСЧЕТ ДЛЯ РЕЗКИ ШТАНГ

STD

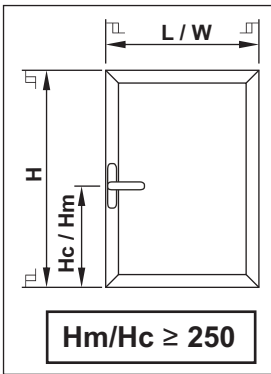
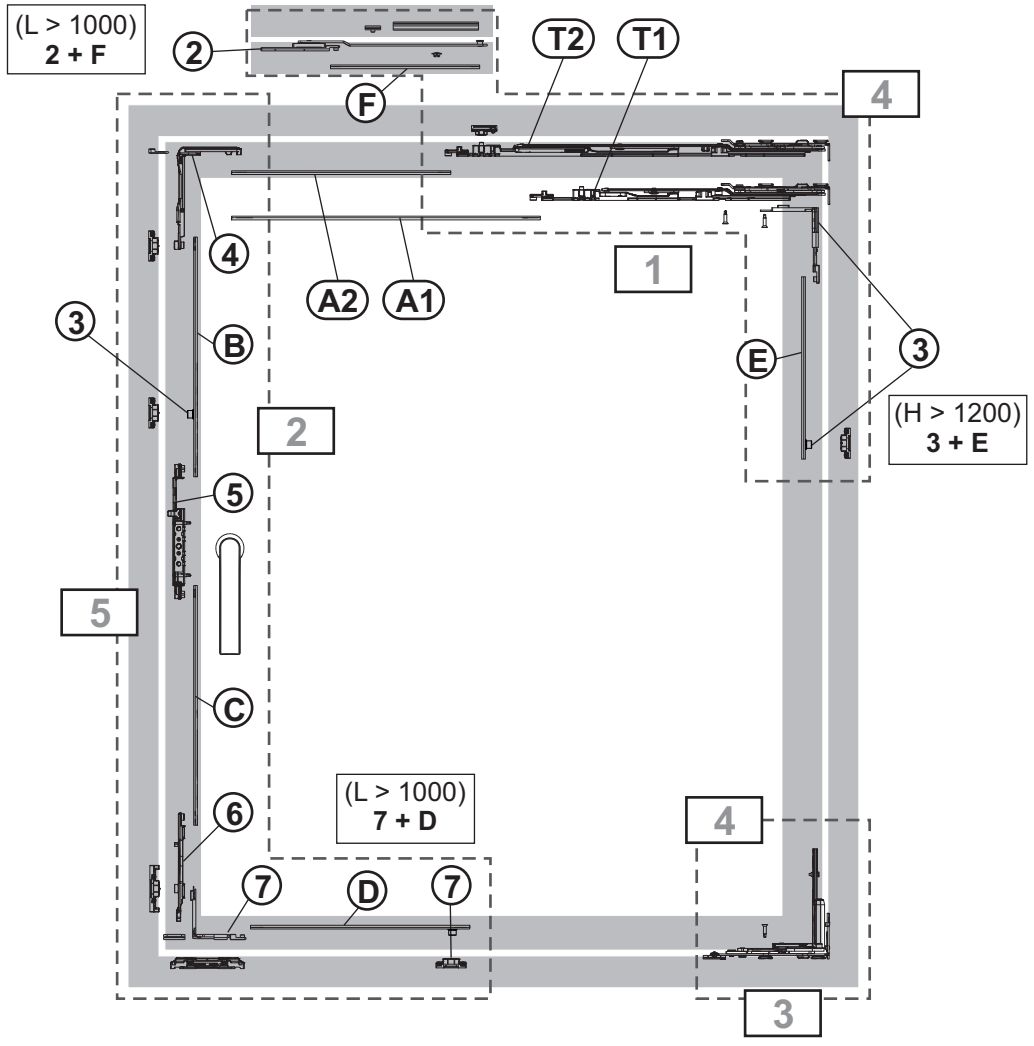

T2 Micro			
T1 Micro			
	470	600	700
	L/W		

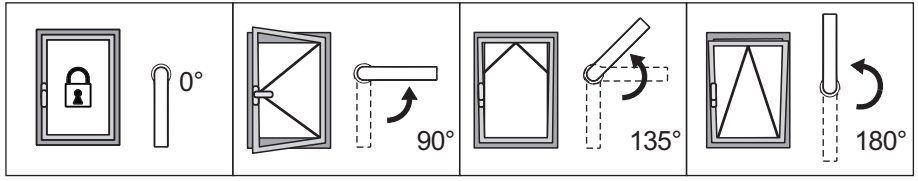

2800		A1=L-415 B=H-Hc-207 C=Hc-207 E=H/2-69		A2=L-538 B=H-Hc-207 C=Hc-207 E=H/2-69		F=L-633 B=H-Hc-207 C=Hc-207 D=L/2-69 E=H/2-69			
	1200		A1=L-415 B=H-Hc-207 C=Hc-207		A2=L-538 B=H-Hc-207 C=Hc-207		F=L-633 B=H-Hc-207 C=Hc-207 D=L/2-69		
600	470	T1 Micro	700	600	T2 Micro	1000	1001	T2 Micro	1600

STD

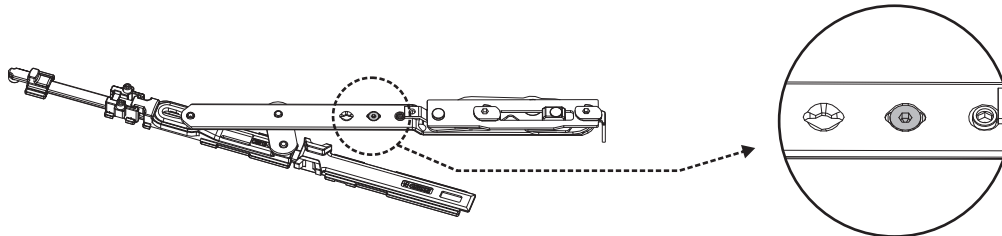
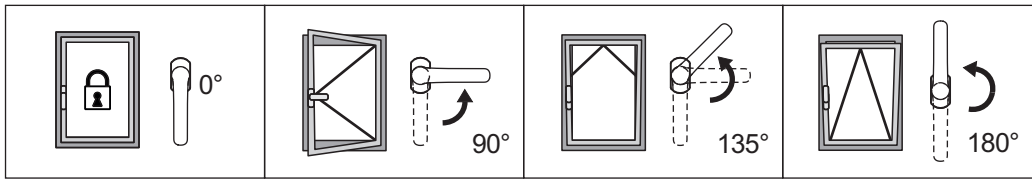

STD

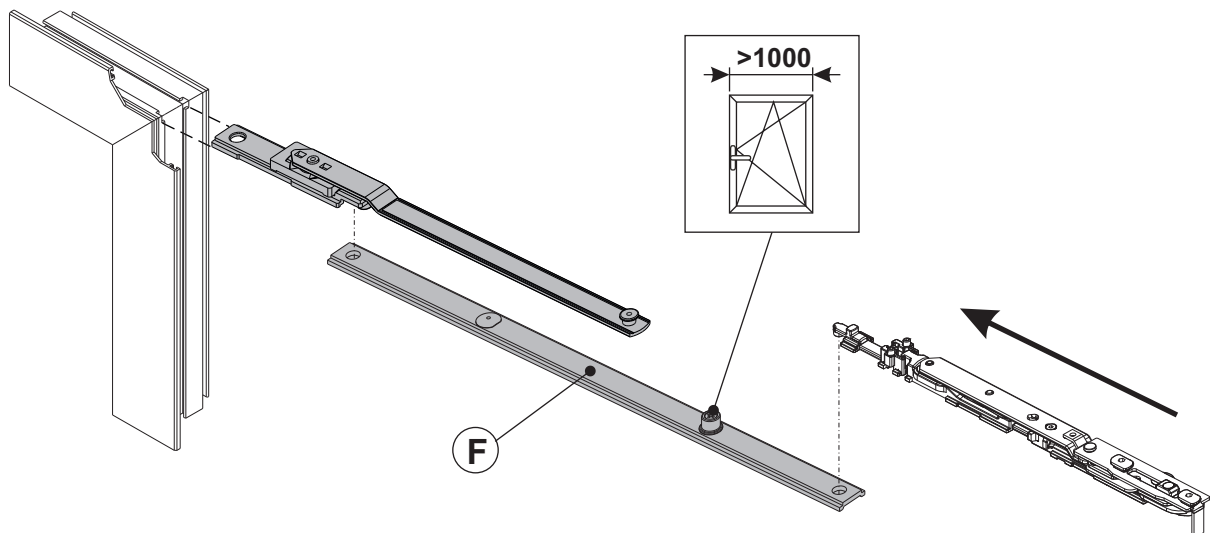
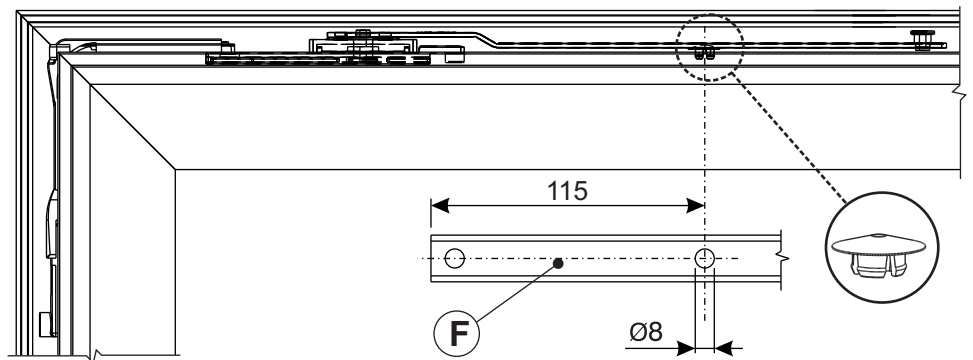
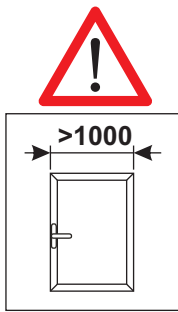
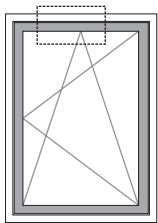

CALCOLO RELATIVO AL TAGLIO ASTE - CÁLCULO RELATIVO AL CORTE DE LAS VARILLAS
 ΥΠΟΛΟΓΙΣΜΟΣ ΚΟΠΗΣ ΛΑΜΑΚΙΩΝ - ROD CUTTING CALCULATIONS - BERECHNUNG DER STANGENLÄNGEN
 CALCUL RELATIF À LA COUPE DES TRINGLES - РАСЧЕТ ДЛЯ РЕЗКИ ШТАНГ

LGC

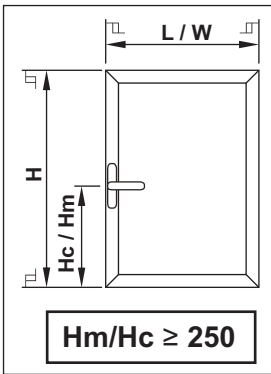
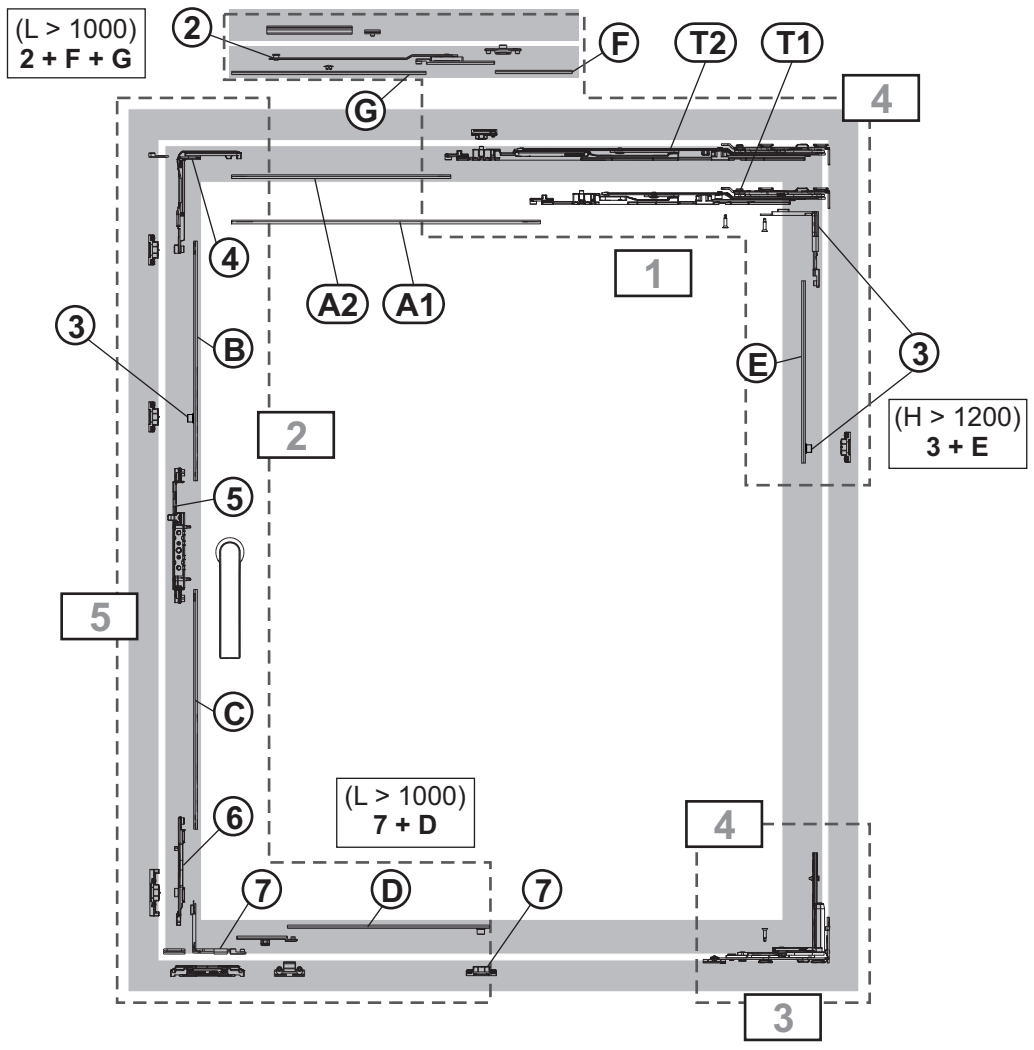

T2 Micro			
T1 Micro			
	470	600	700
	L/W		
		1600	

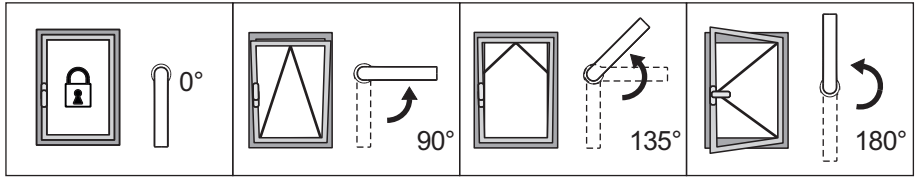

2800	A1	A1=L-415 B=H-Hc-207 C=Hc-207 E=H/2-69	A2	A2=L-538 B=H-Hc-207 C=Hc-207 E=H/2-69	F	F=L-922 B=H-Hc-207 C=Hc-207 D=L/2-69 E=H/2-69 G=268
	B E		B E		B E	
1200	A1	A1=L-415 B=H-Hc-207 C=Hc-207	A2	A2=L-538 B=H-Hc-207 C=Hc-207	F	F=L-922 B=H-Hc-207 C=Hc-207 D=L/2-69 G=268
600	B C		B C		B C	
	470	T1 Micro	600	T2 Micro	1001	T2 Micro
		700		1000		1600

LGC

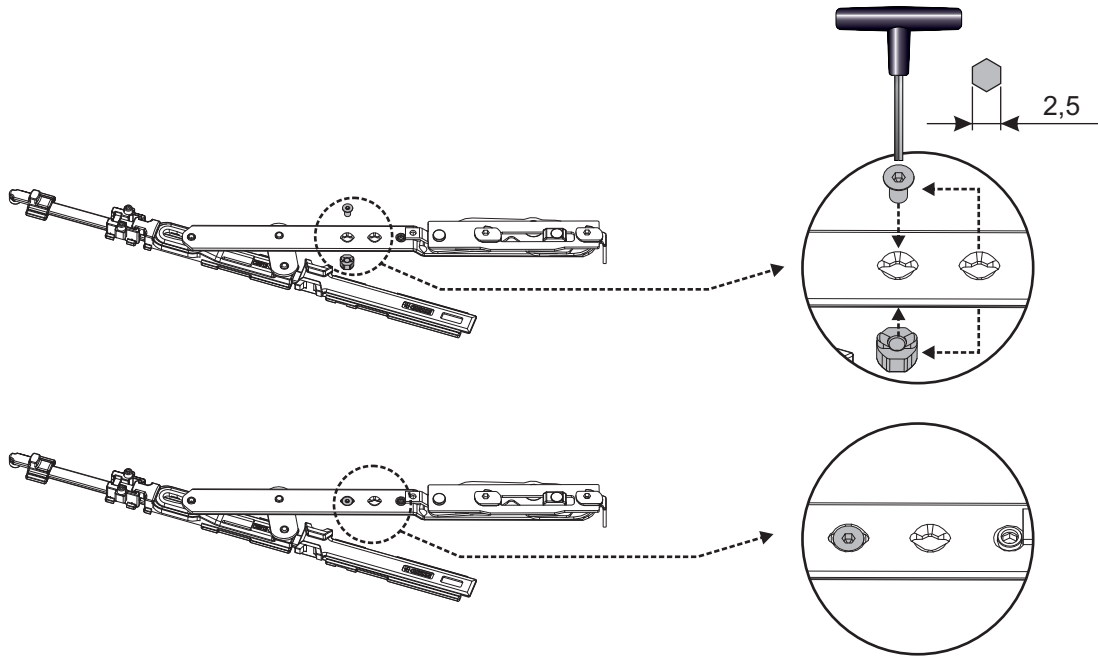
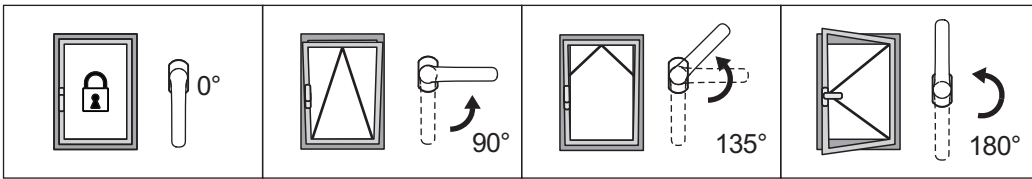

LGC

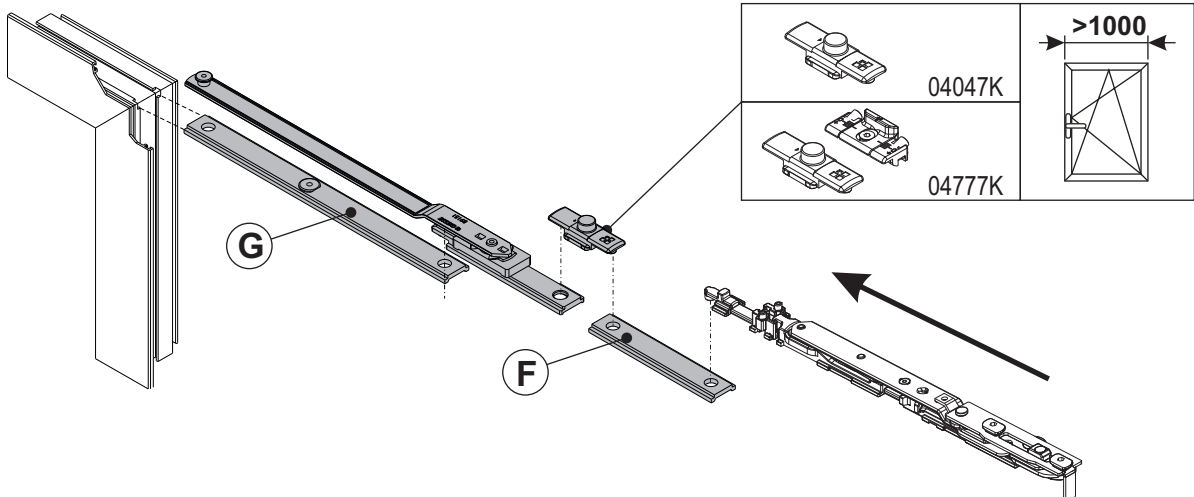
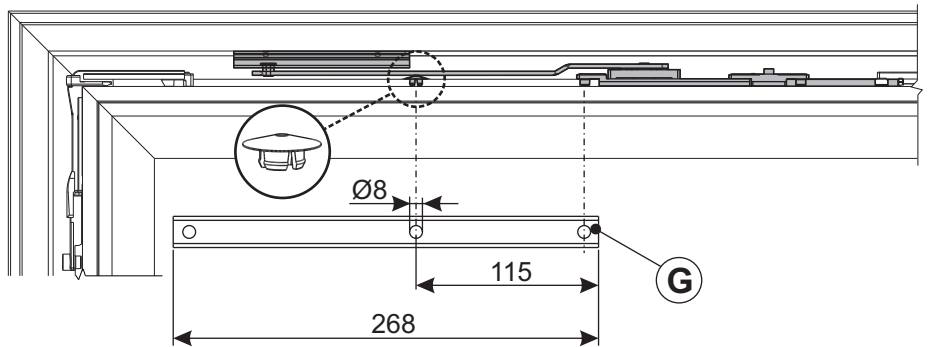
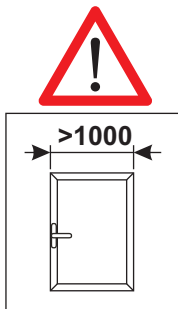
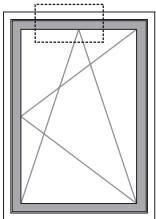

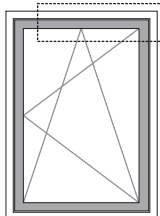

1 STD LGC 

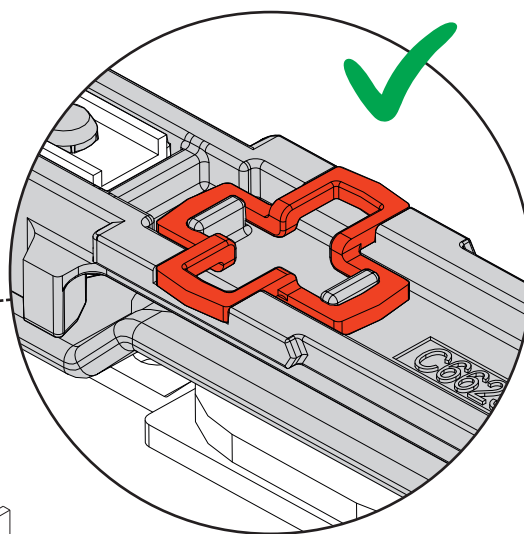
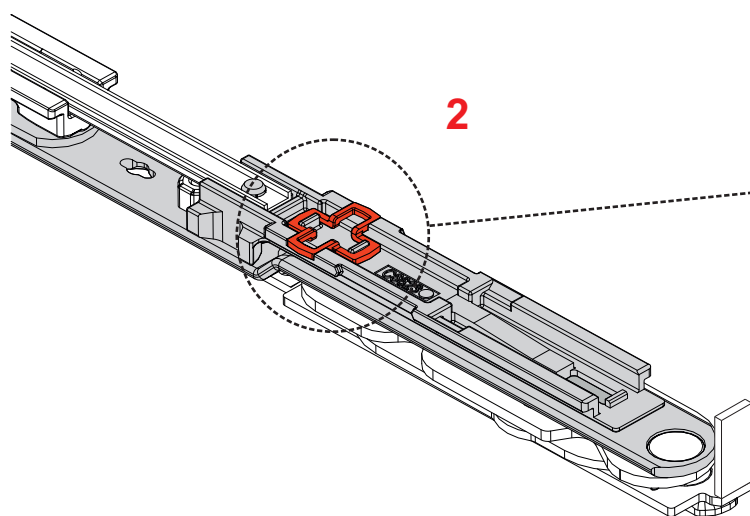
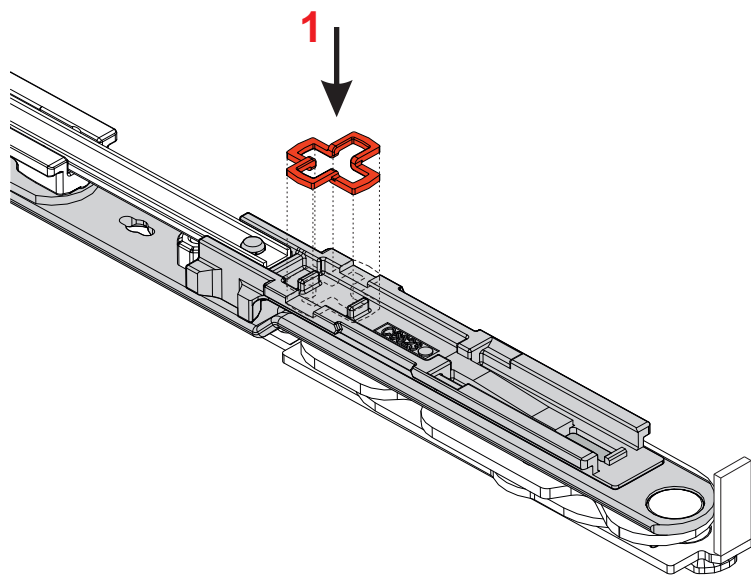
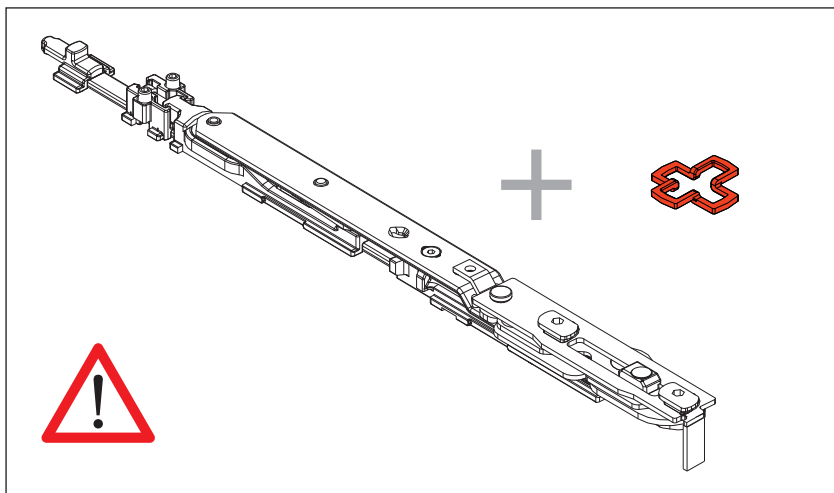

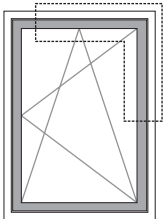

2 STD LGC 

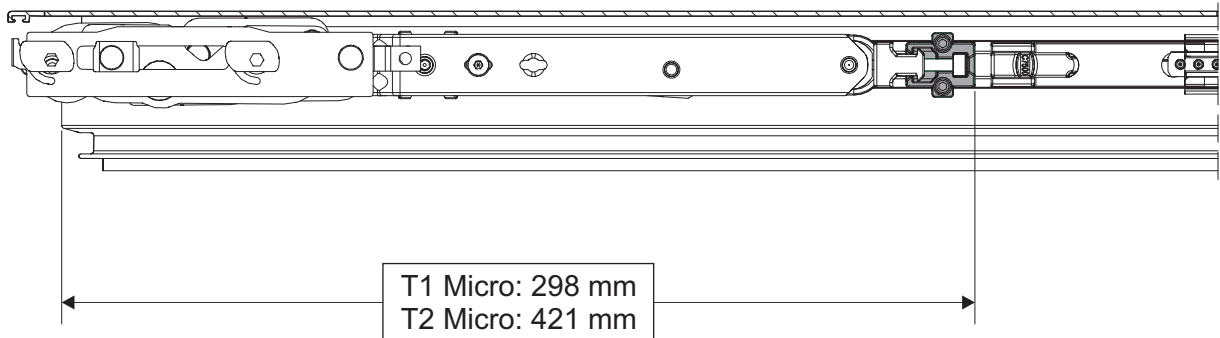
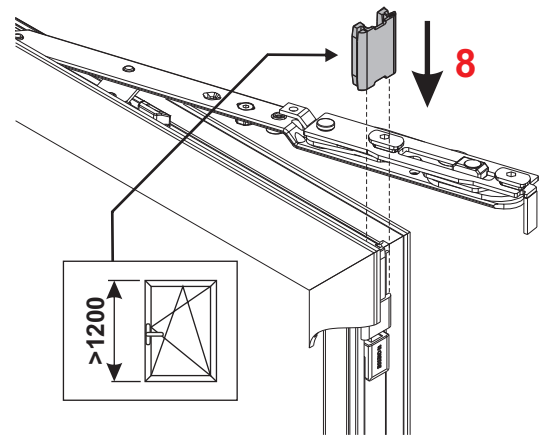
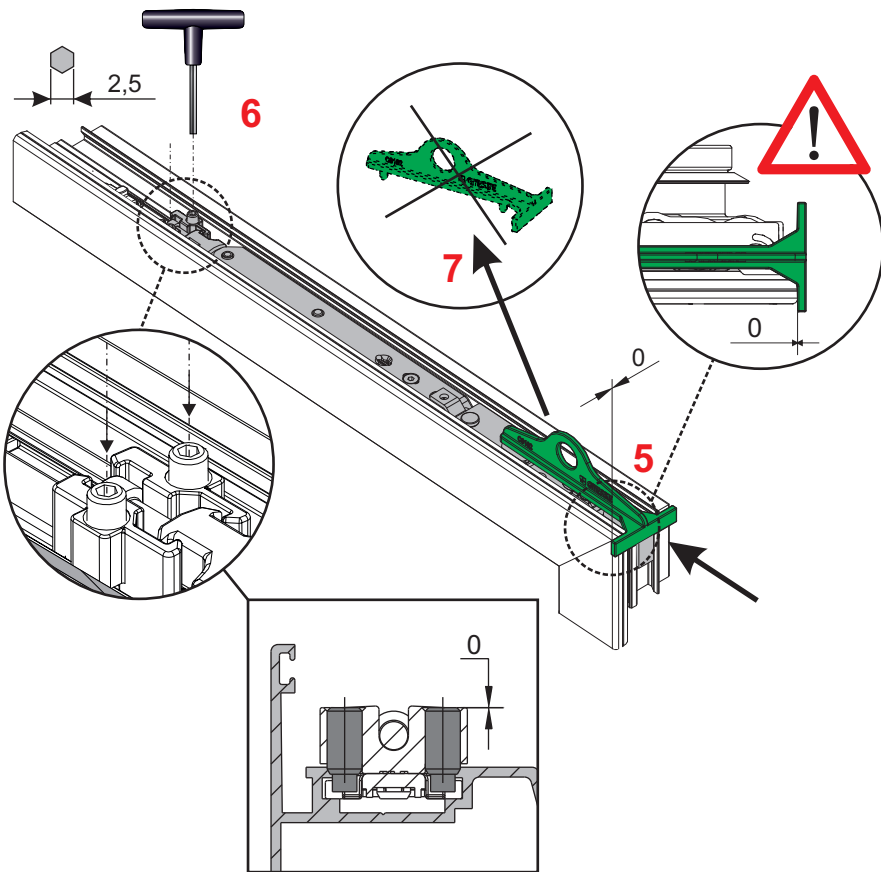
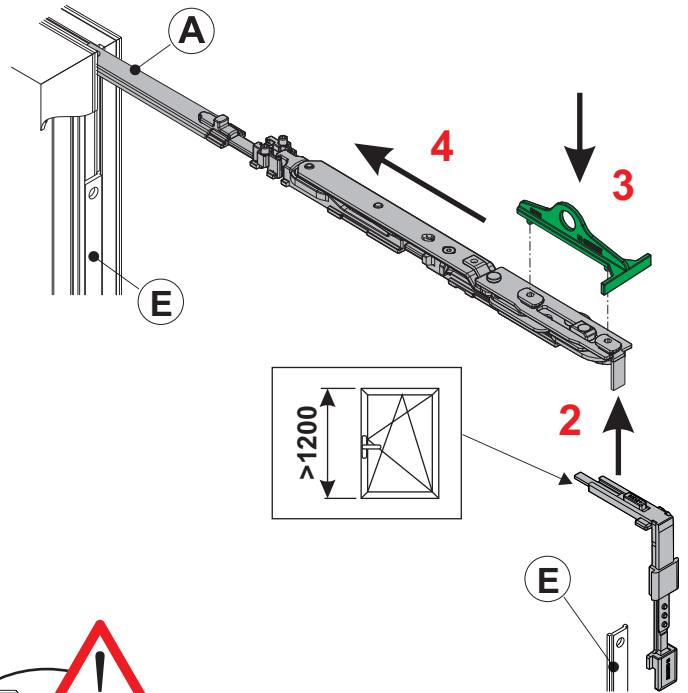
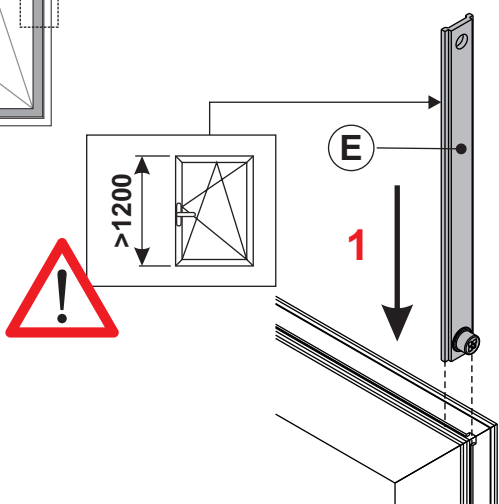

T1 Micro: 298 mm
T2 Micro: 421 mm

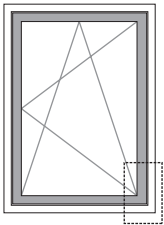

3 STD LGC 

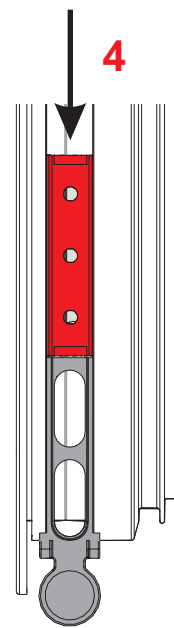
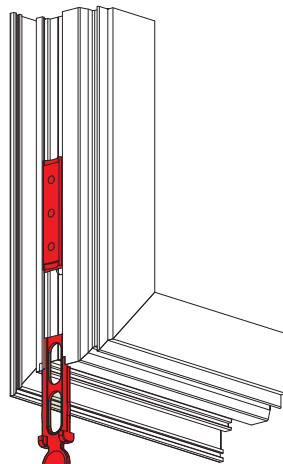
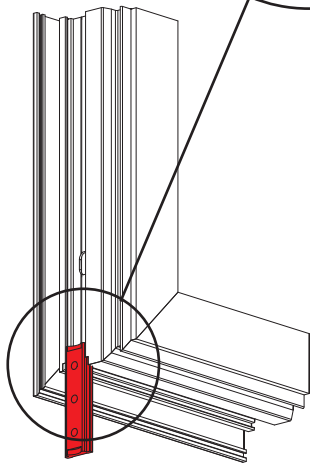
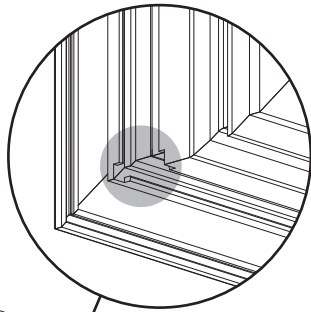
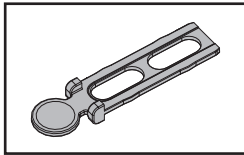

4

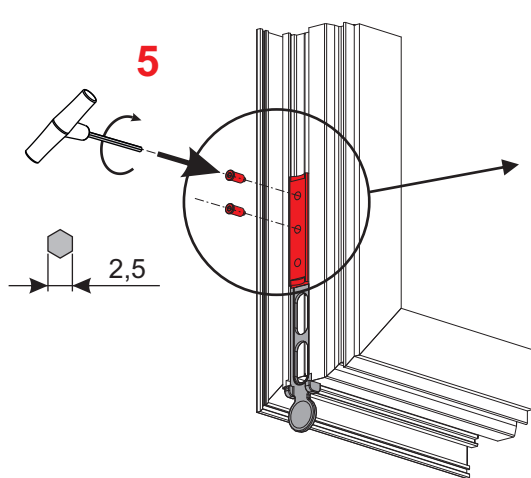

5

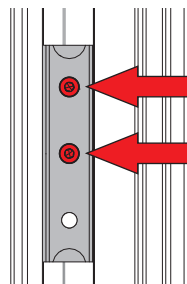

6

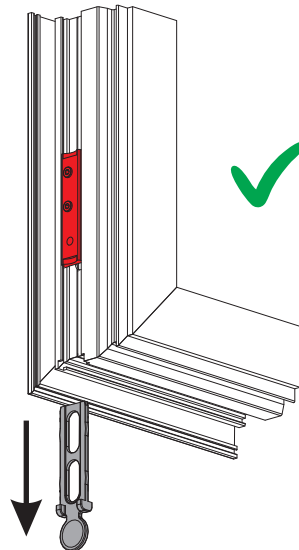

4 STD LGC 

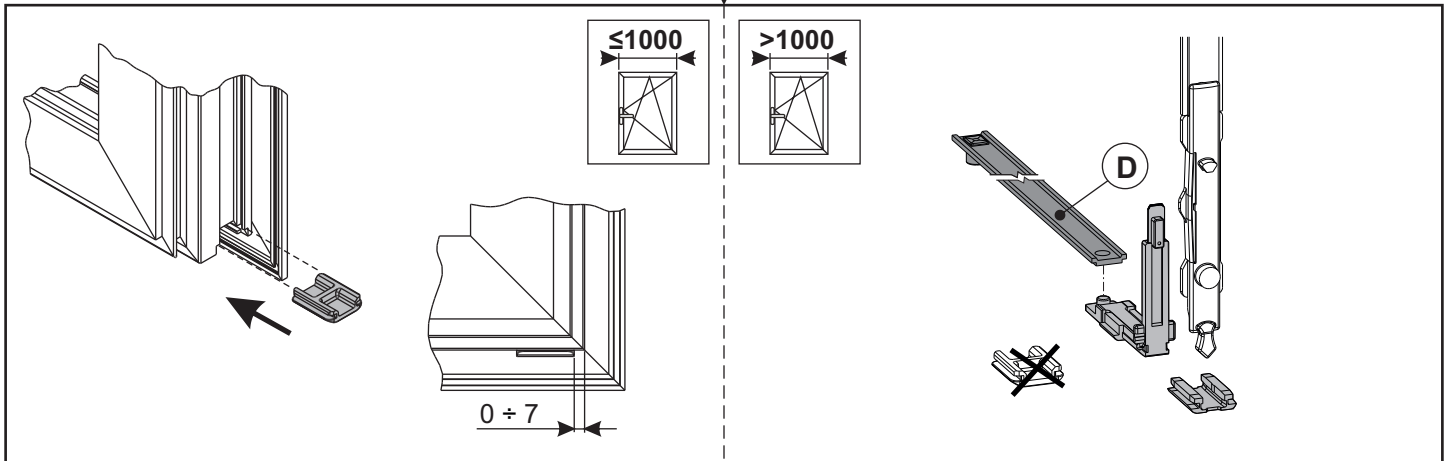
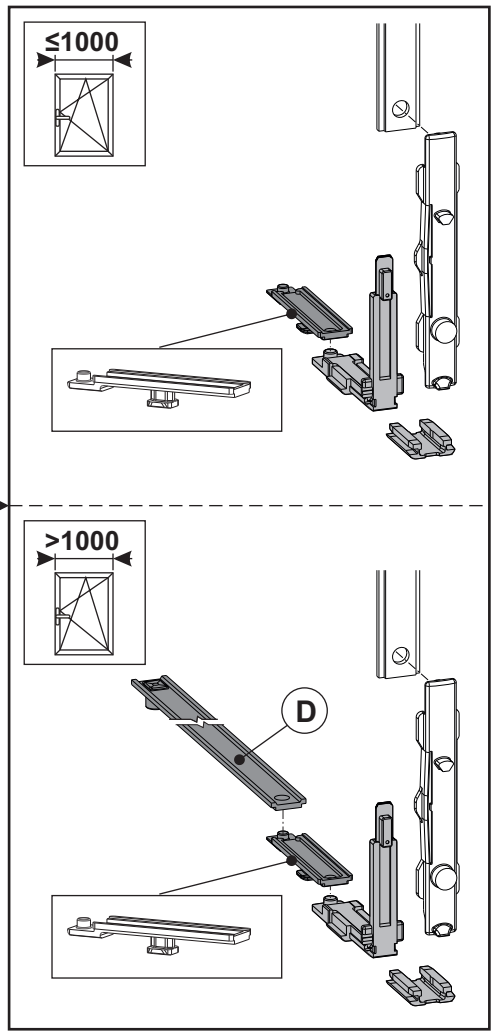
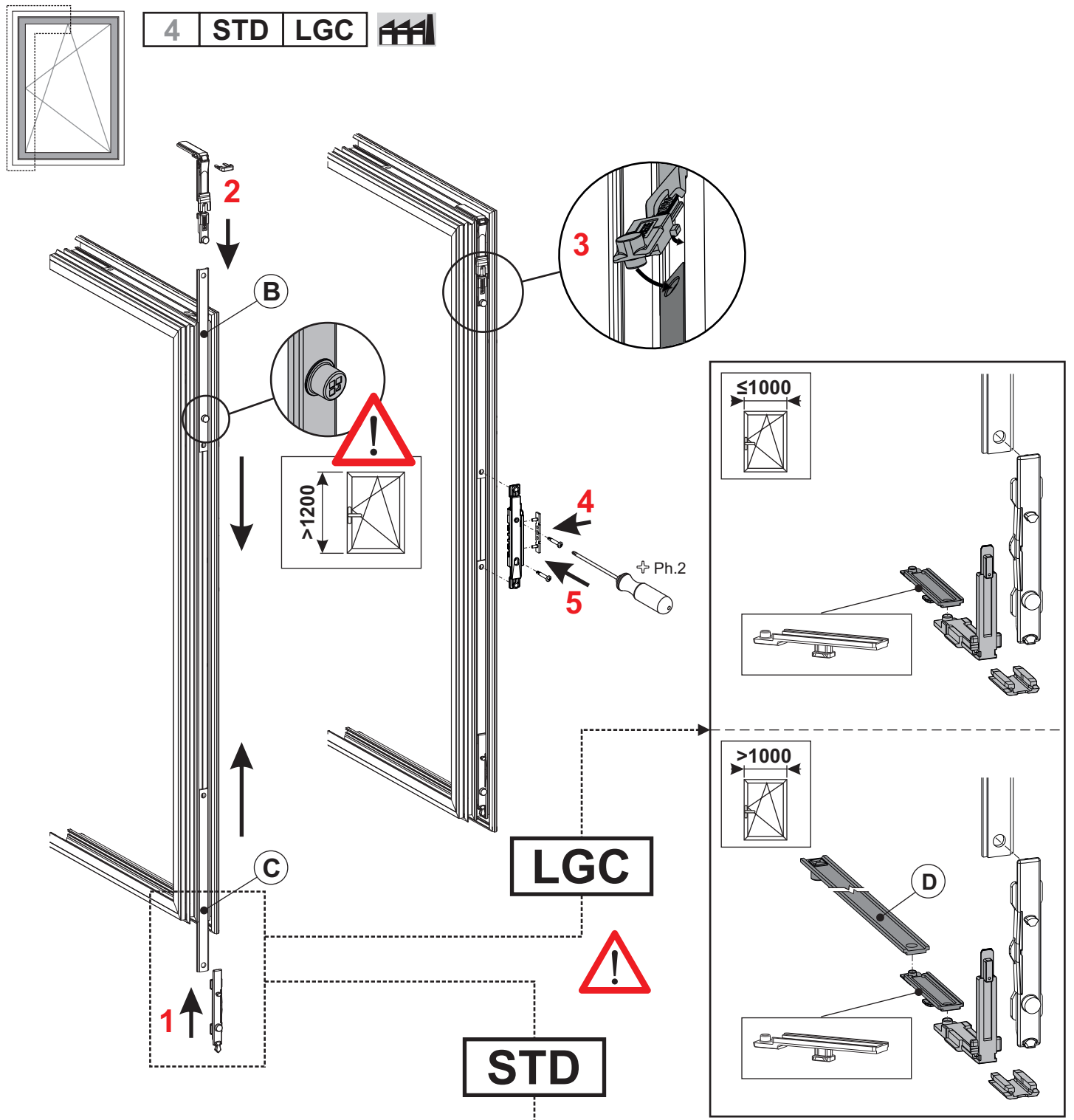

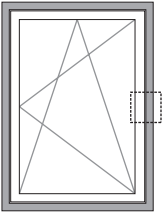

5 STD LGC

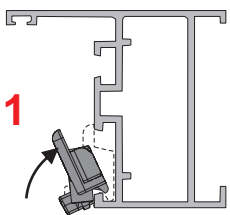
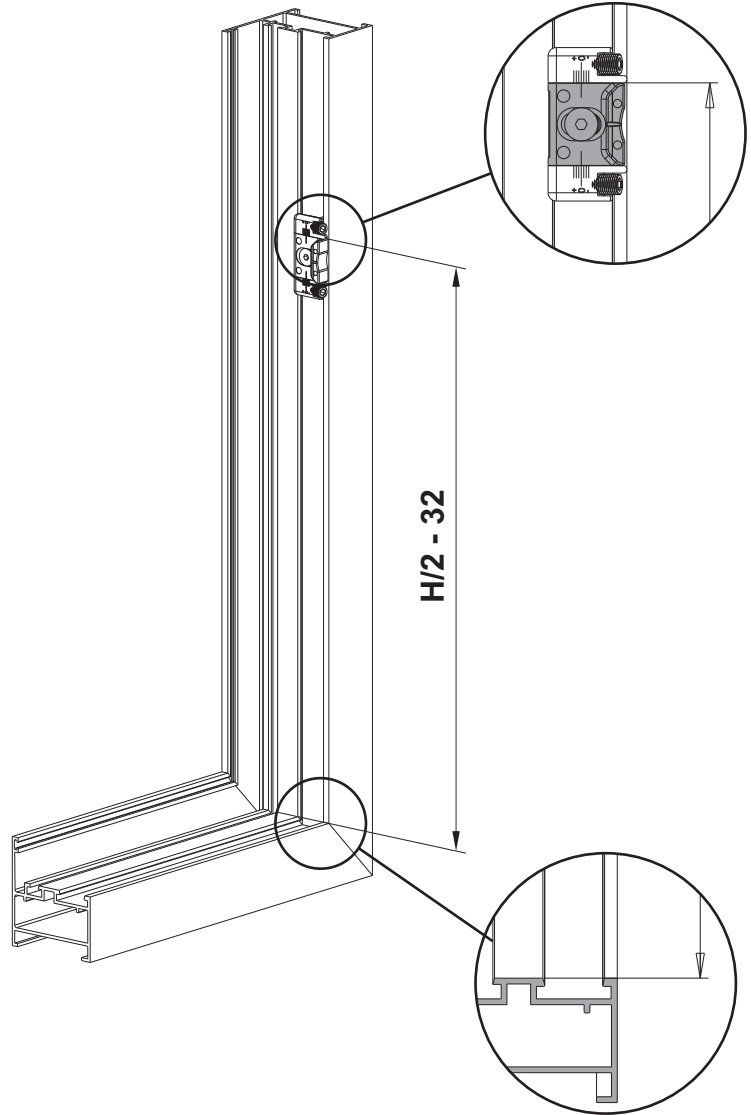
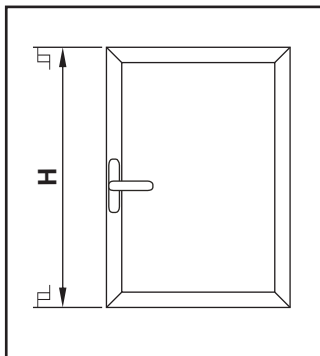
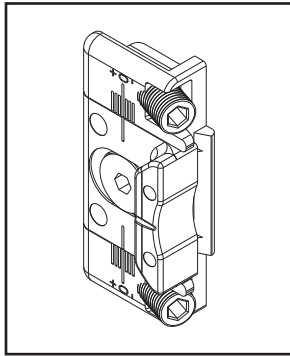

1

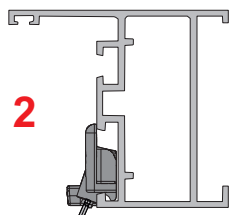

2

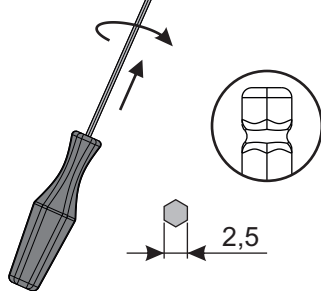

2,5

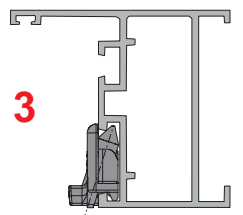
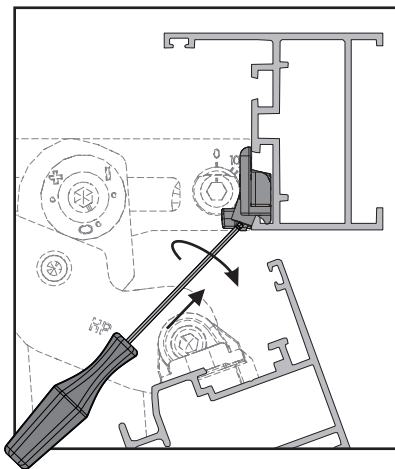

3



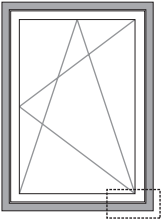

6 STD LGC 

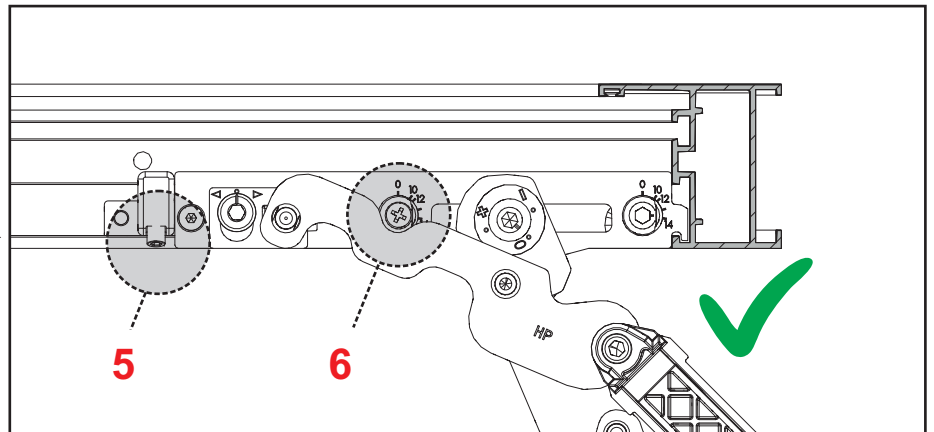
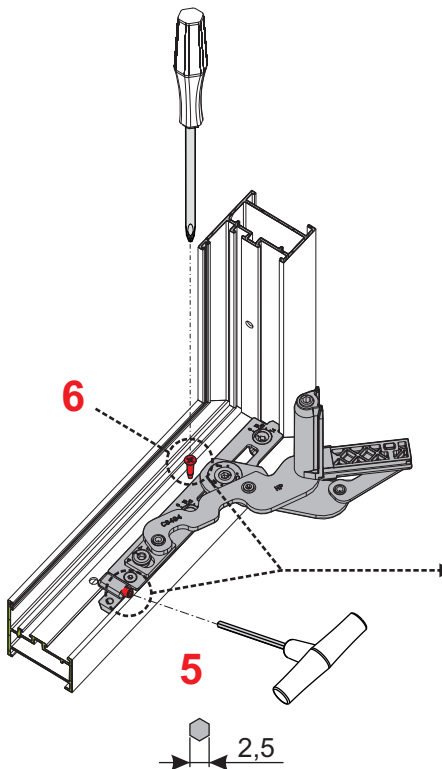
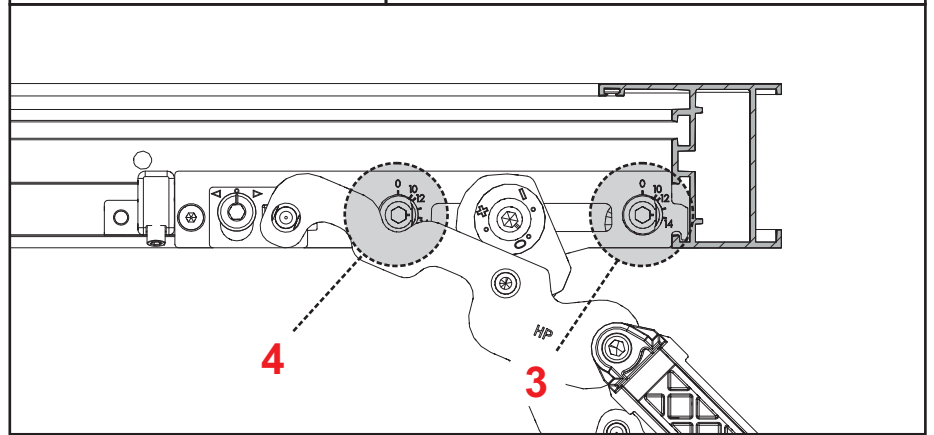
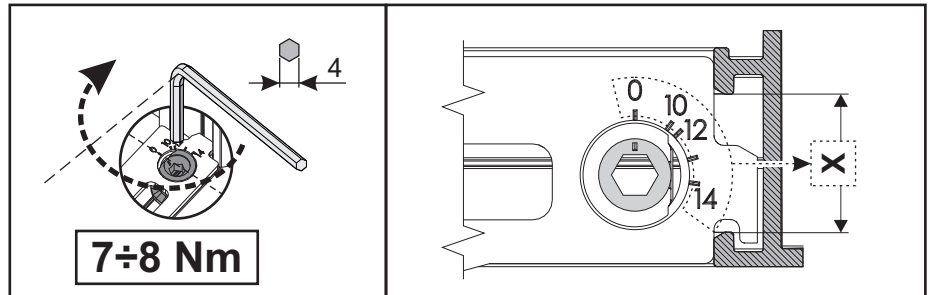
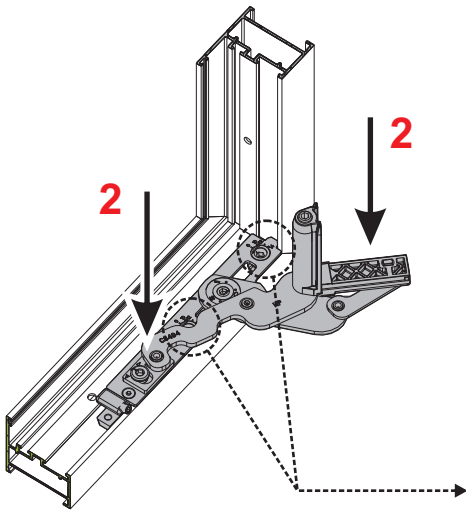
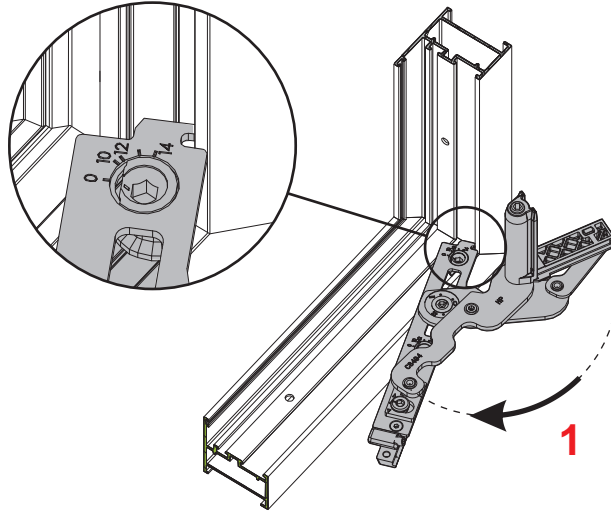

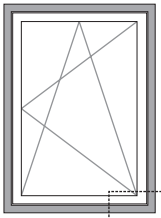

7 STD LGC

A

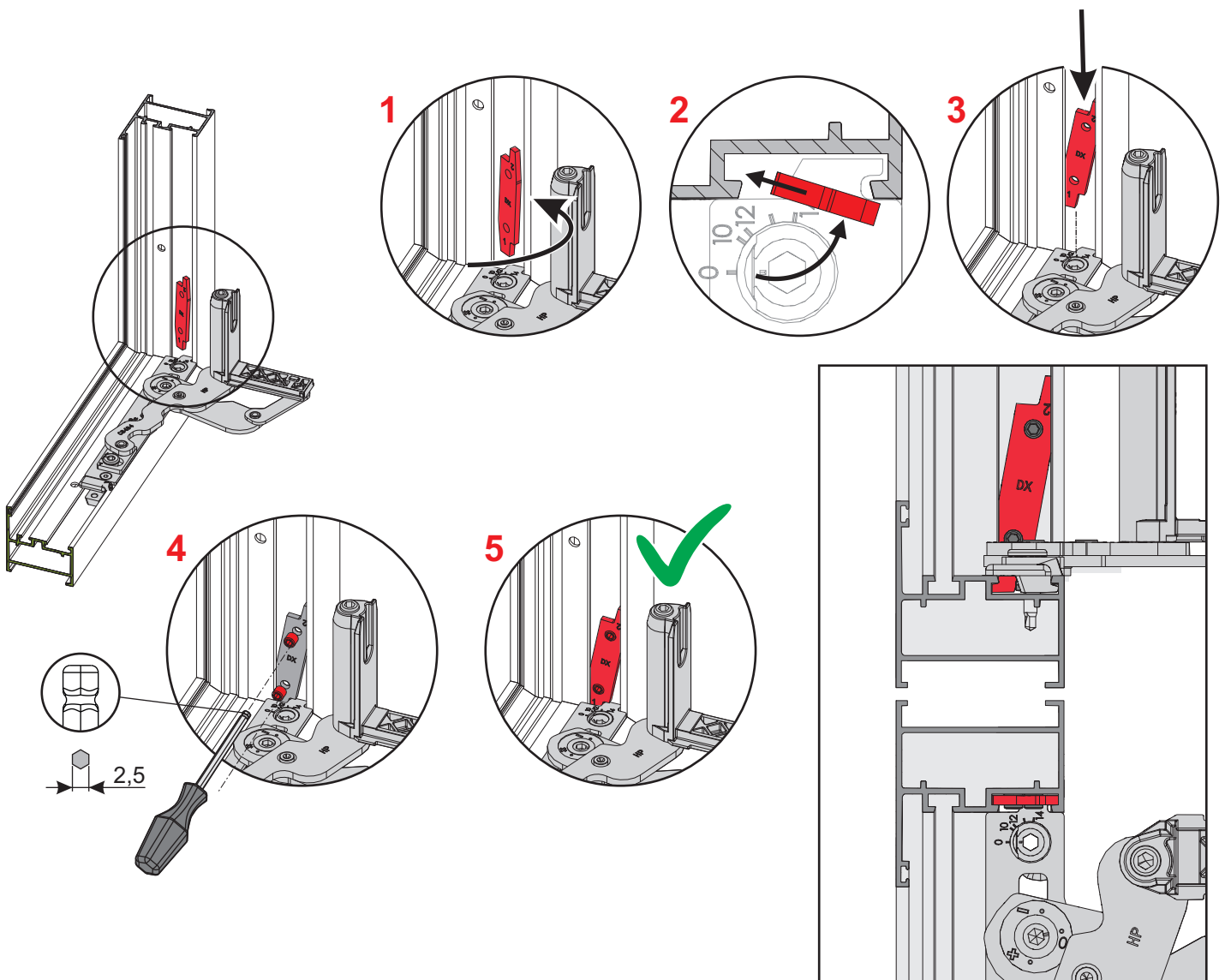
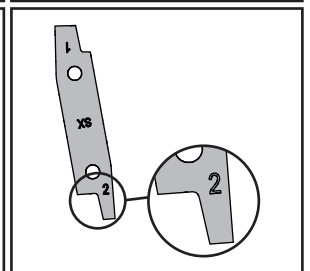
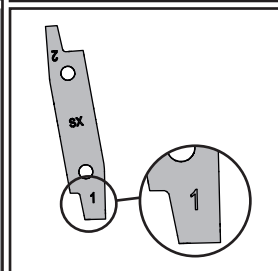
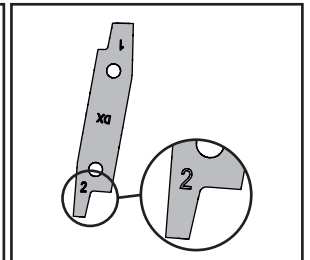
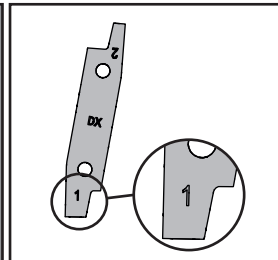
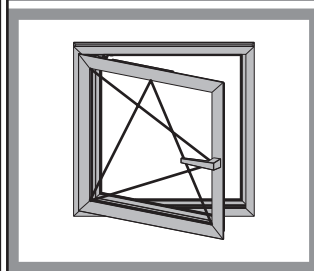
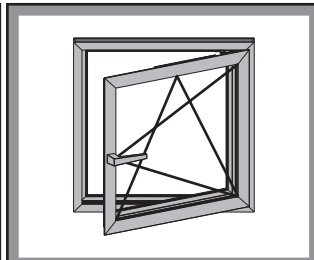
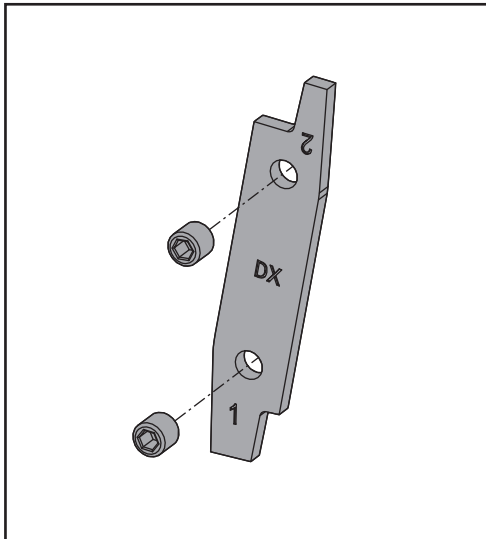
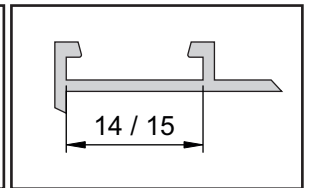
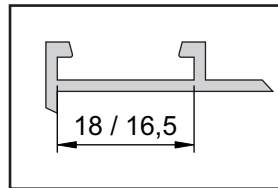

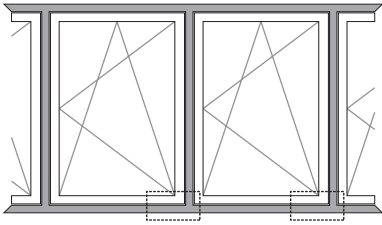

7 STD LGC

B

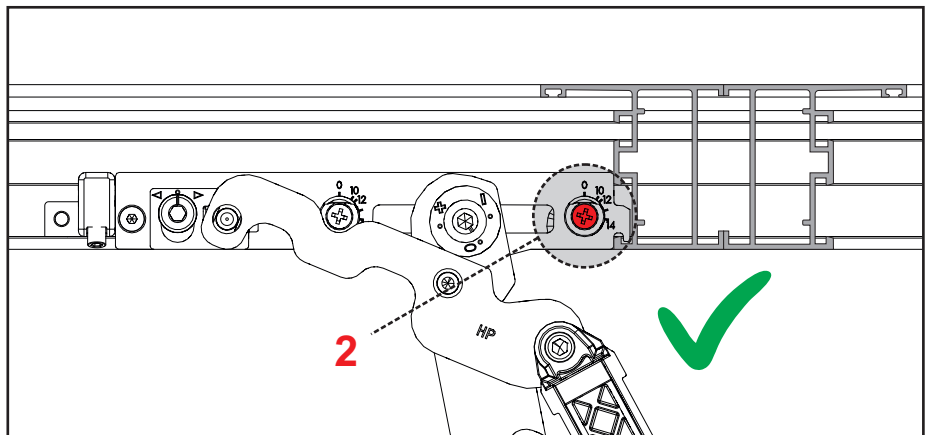
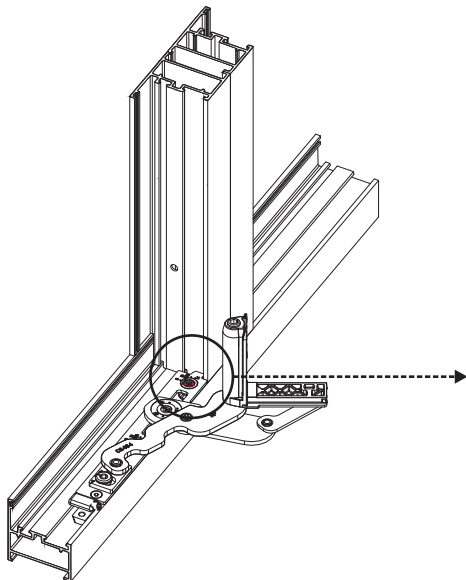
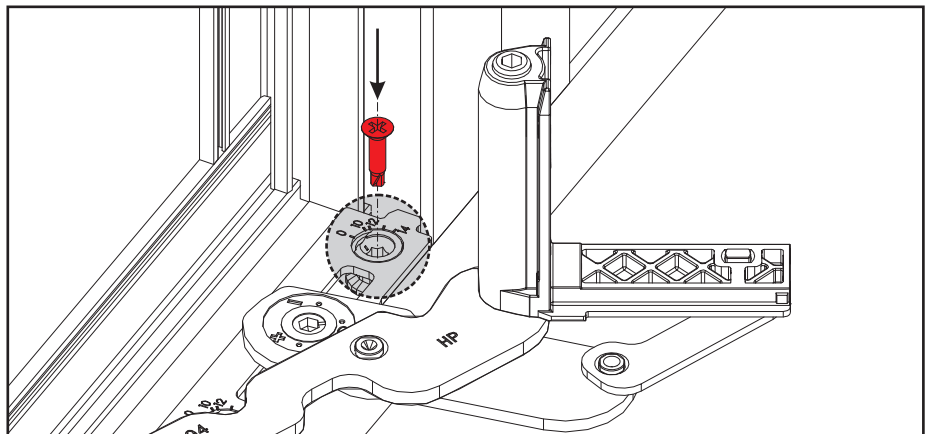
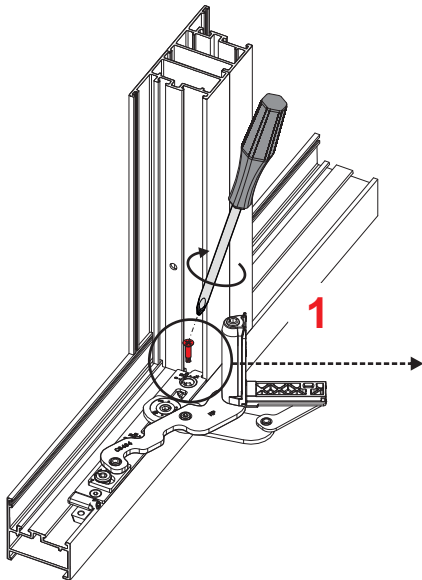
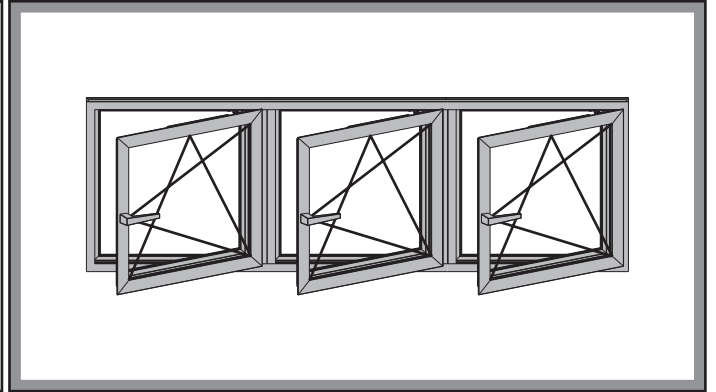
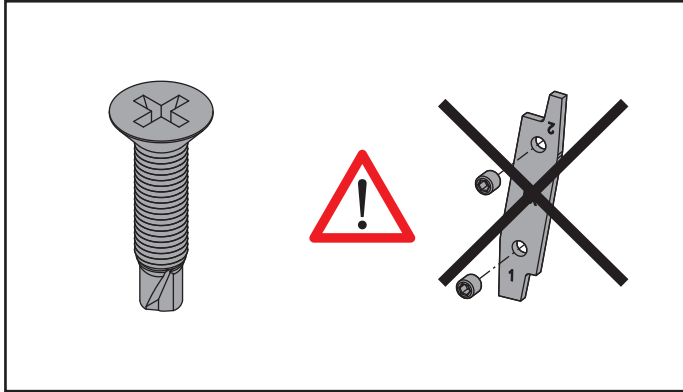

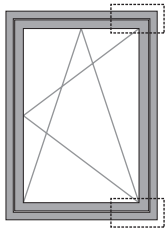

8 STD LGC 

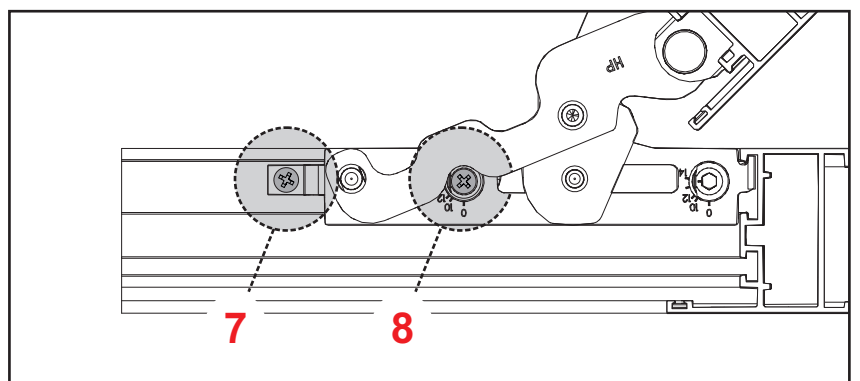
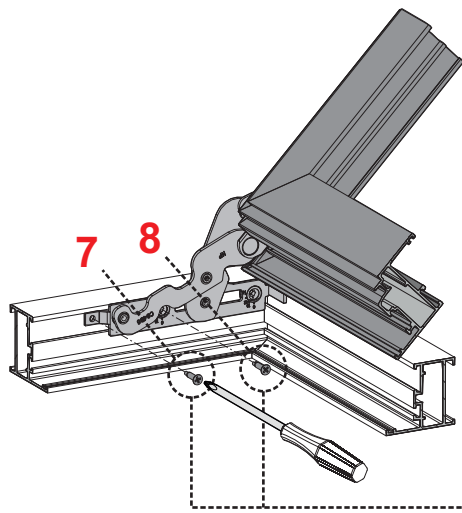
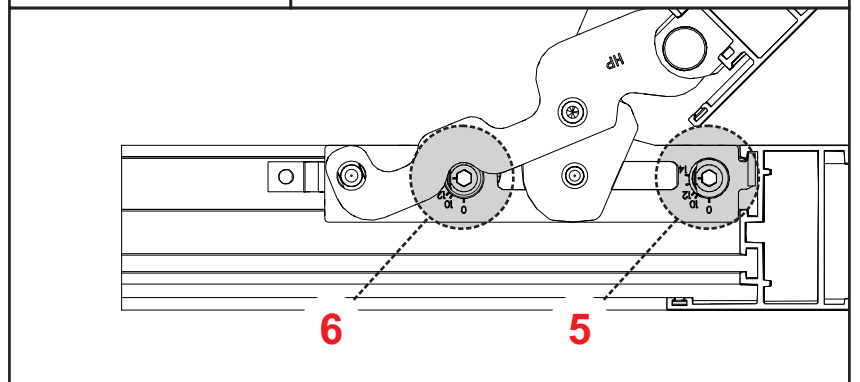
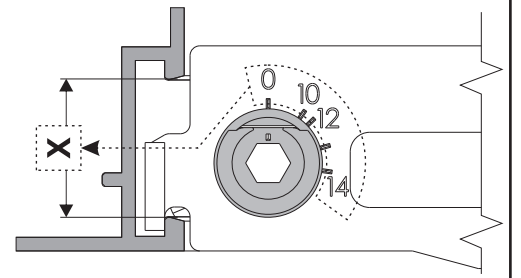
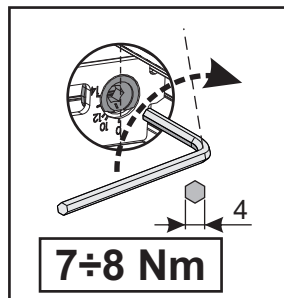
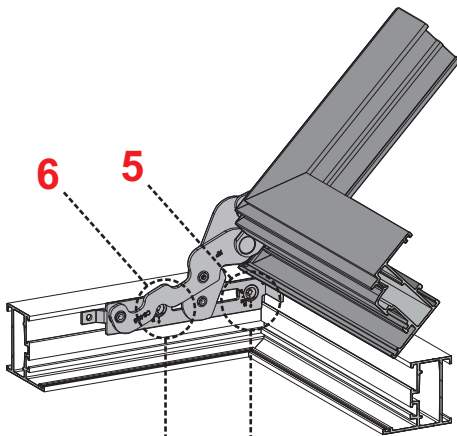
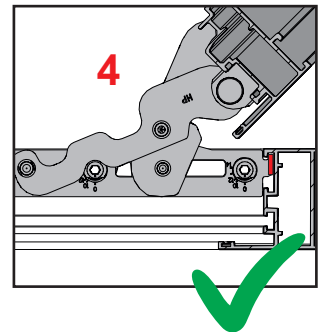
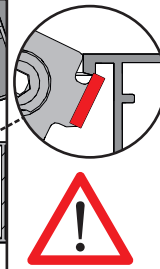
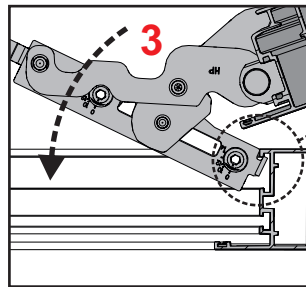
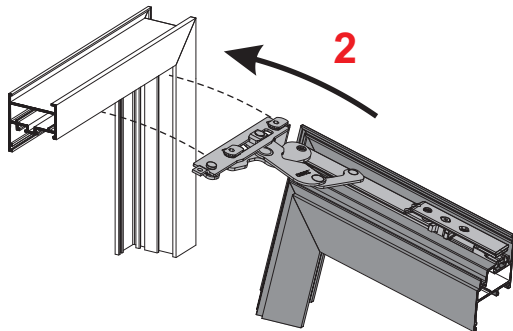
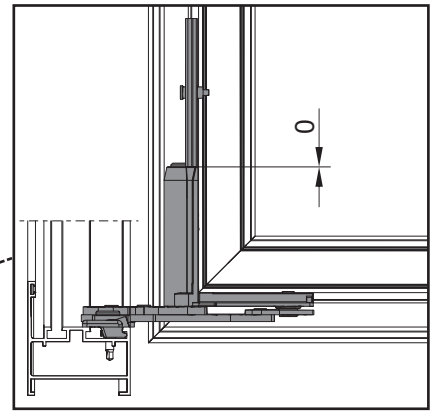
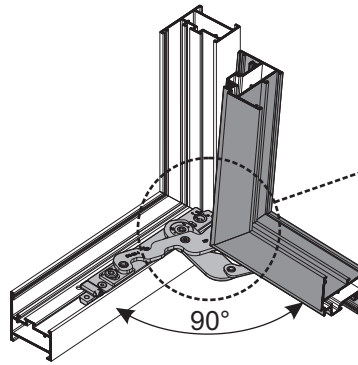
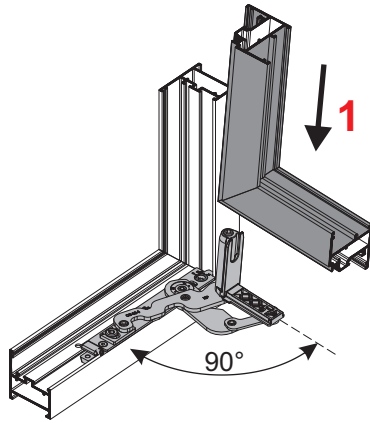

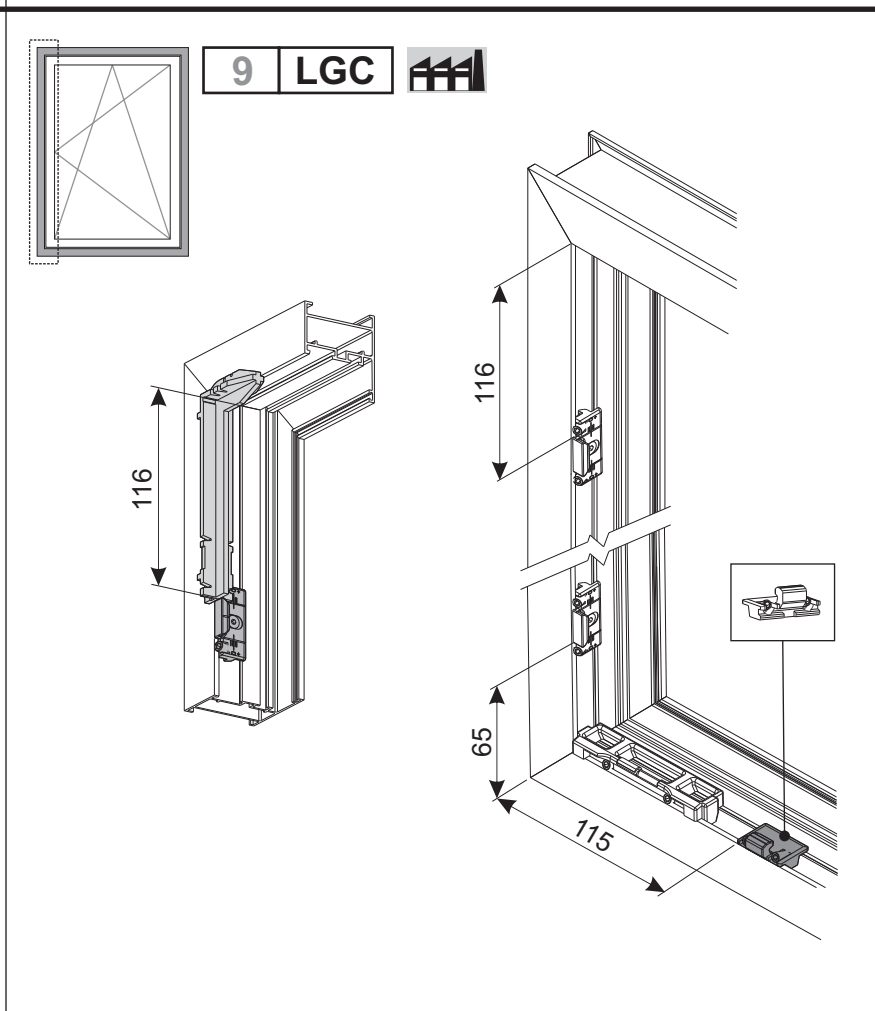
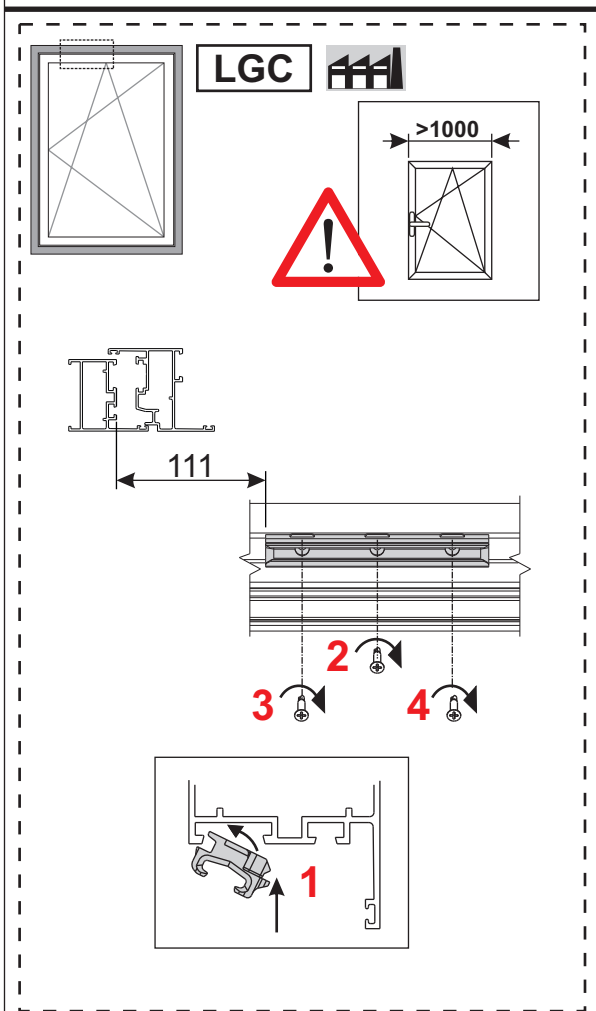
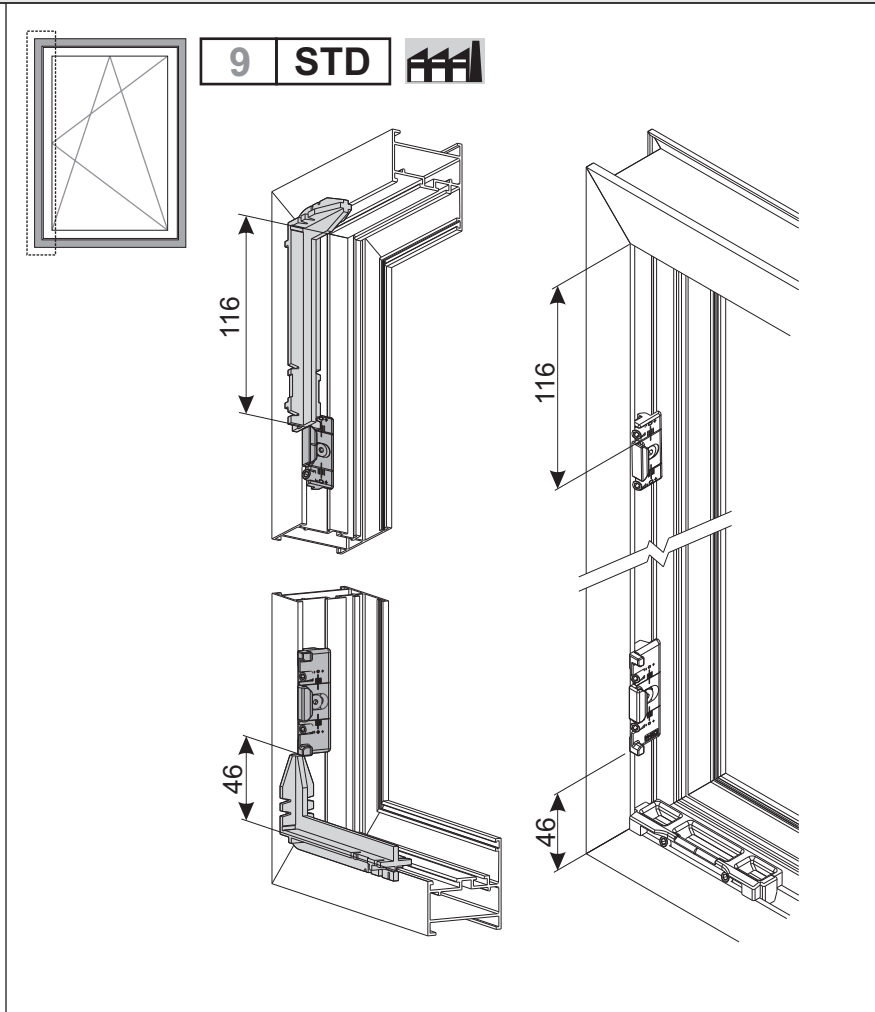
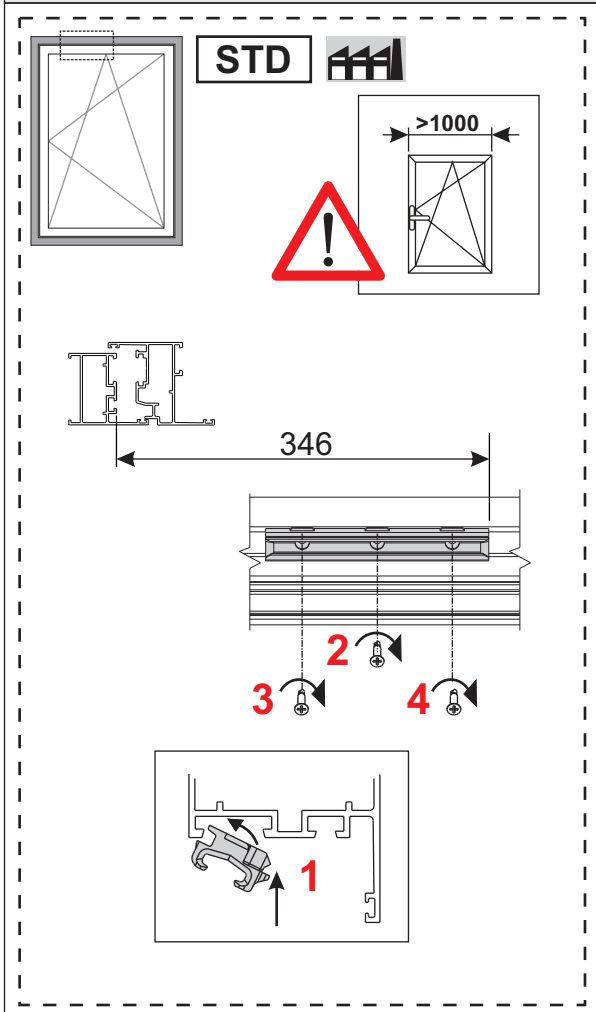

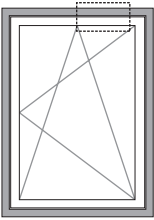

10 STD LGC



* Quote indicative da verificare sull'anta installata e regolata con cremone in posizione microventilazione.

Indicative distance to be checked on the leaf installed and adjusted in position with microventilation cremone.

Cotas indicativas para el control de la hoja ensamblada y regulación cremona en posición de microventilación.

Die Maße sind zu überprüfen auf den montierten Flügel, und reguliert mit dem Griff bei der Mikrobeflüchtung Position.

Η απόσταση τοποθέτησης είναι ενδεικτική. Ελέγξτε αφού πρώτα τοποθετήσετε το φύλλο και βάλετε την σπανιολέτα στην θέση μικροεξαερισμού.

Cotes à vérifier sur l'ouvrant installé et réglé avec la crémone en position microventilation.

