

Lubrificare con prodotti a base di vaselina sia le guide che tutti i meccanismi prima del loro inserimento.

Impiegare astine di collegamento in poliammide o in alternativa in alluminio con trattamento di ossidazione e non di verniciatura.

Si garantisce il funzionamento dell'accessorio descritto in queste istruzioni solo se l'infisso è stato installato a regola d'arte, quindi in squadra e senza impedimenti nell'apertura totale dell'anta.

Nel caso in cui l'infisso richieda il braccio FRIZ: L > 635 mm.

Lubricar con productos a base de vaselina tanto las guías como todos los mecanismos antes de introducirlos.

Utilizar varillas de conexión de poliamida o en alternativa de aluminio con tratamiento de oxidación y sin pintura.

Se garantiza el funcionamiento del accesorio descrito en estas instrucciones sólo si el bastidor se ha instalado correctamente, es decir, en escuadra y sin obstáculos en la apertura total de la hoja.

En el caso que la ventana requiera el brazo FRIZ: L > 635 mm.

Λιπάνετε με προϊόντα που έχουν ως βάση την βαζελίνη, τους οδηγούς αλλά και όλους τους μηχανισμούς πριν την εισαγωγή τους.

Χρησιμοποιήστε ντίξες σύνδεσης πολυαμιδίου ή εναλλακτικά αλουμινίου με επεξεργασία ανοδίωσης και όχι με βαφή πούδρας.

Εγγυόμαστε τη καλή λειτουργία του εξαρτήματος που περιγράφονται σε αυτές τις οδηγίες μόνο αν το κούφωμα

είναι εγκατεστημένο με τον κατάλληλο τρόπο, δηλαδή ευθυγραμμισμένο και χωρίς εμπόδια στο σύνολο του ανοίγματος του φύλλου. Στην περίπτωση κατά την οποία το κούφωμα απαιτεί τον βραχίονα FRIZ: L > 635mm.

Use vaseline-based products to lubricate both the guides and all the mechanisms before inserting them. Use polyamide connecting rods or aluminium connecting rods which have been subject to oxidation treatment and not painted. Correct functioning of the accessory described in these instructions is only guaranteed if the window has been installed correctly, that is, flush and without obstacles preventing total wing opening. If the window requires the FRIZ arm: L > 635 mm.

Die Führungen und alle Getriebeteile vor dem Einbau mit Vaseline einfetten. Polyamid-Verbindungsstangen oder Verbindungsstangen aus eloxiertem und unlackiertem Aluminium verwenden. Die einwandfreie Funktion des in dieser Anleitung beschriebenen Beschlags ist nur dann gewährleistet, wenn das Fenster sachgerecht montiert wurde, d.h. lotrecht und ohne Hindernisse bei der vollständigen Öffnung des Flügels. Falls das Fenster eine Schere FRIZ erfordert: Länge L > 635 mm aufweist.

Avant tout montage, lubrifier les guides et tous les mécanismes avec des produits à base de vaseline. Utiliser des tringles en polyamide ou en aluminium ayant subi un traitement contre l'oxydation et non un vernissage. Le bon fonctionnement de l'accessoire qui est décrit dans les présentes instructions est garanti uniquement si la fenêtre est montée dans les règles de l'art, c'est-à-dire à angle droit et sans que l'ouverture

totale du vantail soit entravée. Lorsque le bras FRIZ est nécessaire pour des châssis: la longueur doit être L > 635 mm.

Прежде чем установить направляющие и механизмы, следует смазать их составами на основе вазелина. Используйте соединительные штанги из полиамида или, в качестве альтернативы, штанги из алюминия, подвергнутые оксидированию, но не окраске. Работа описанной в инструкциях принадлежности гарантируется только при условии безукоризненной ее установки, т.е. под прямым углом и без препятствий для полного раскрытия створки на. В том случае, когда для установки переплета необходим кронштейн FRIZ: длина L > 635 мм.

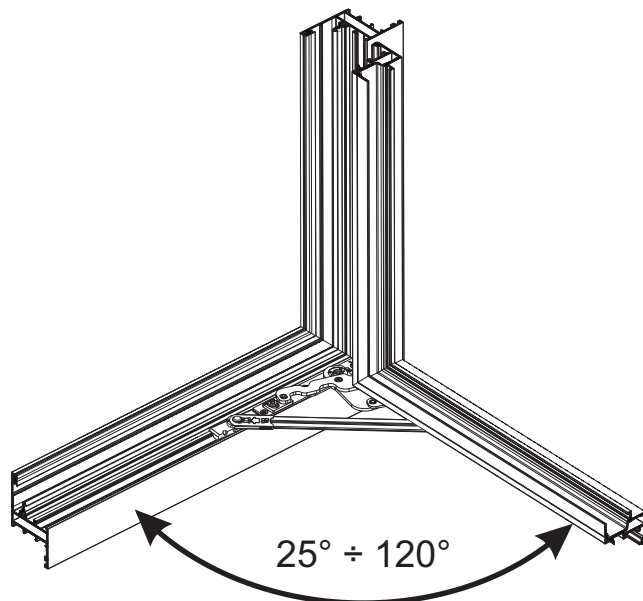
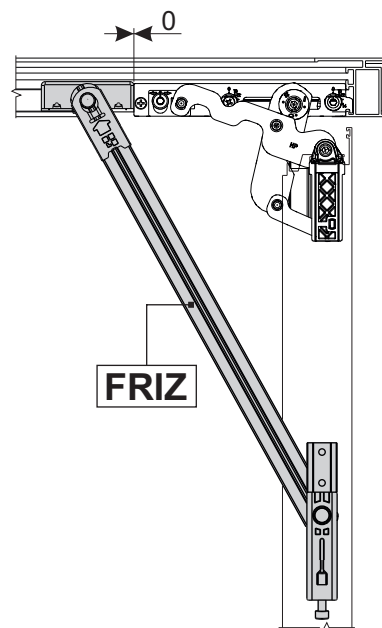
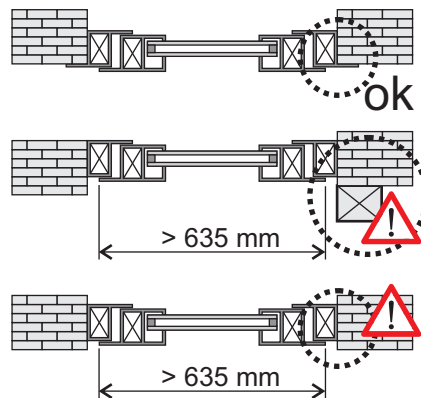

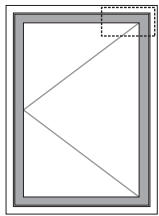

1

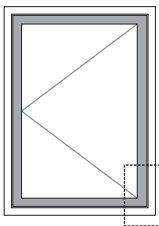
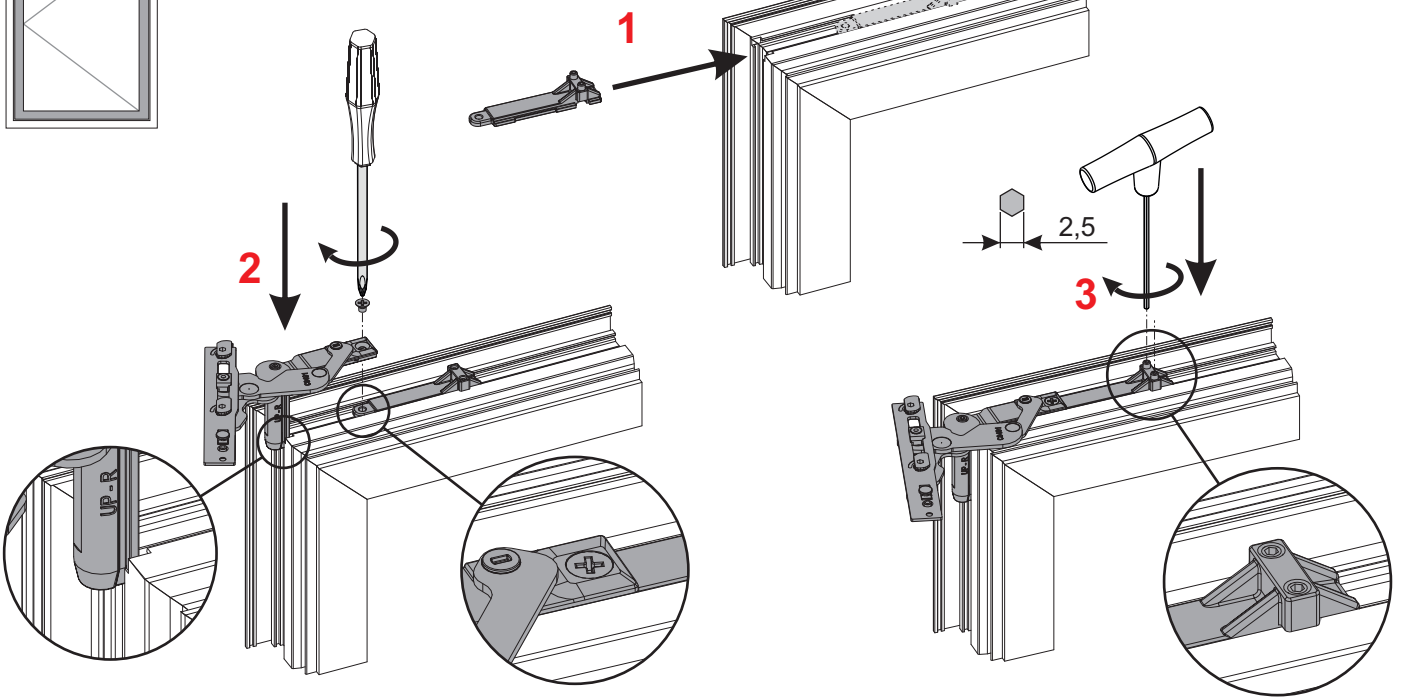

2

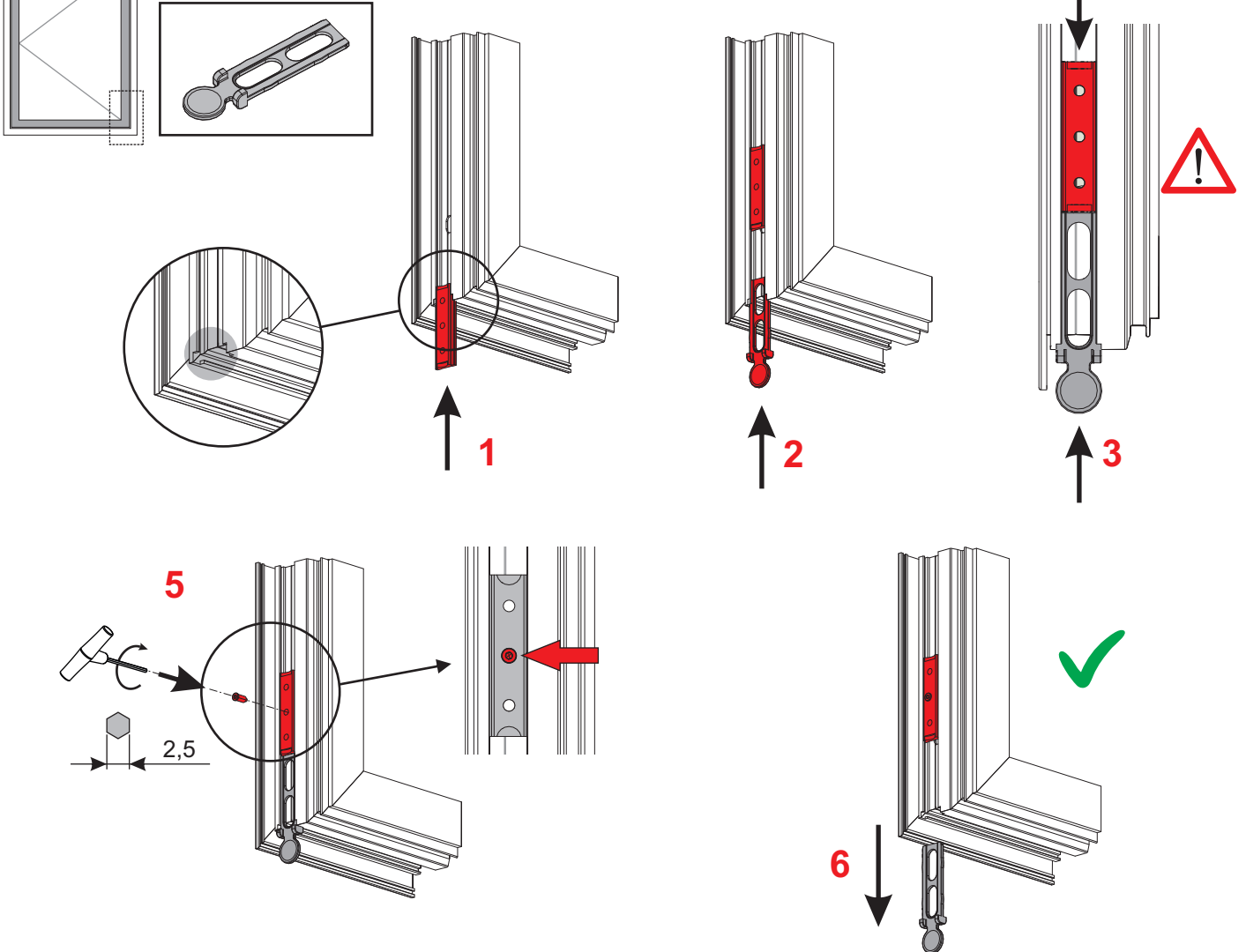

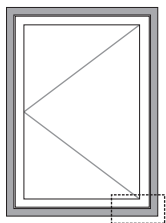

3

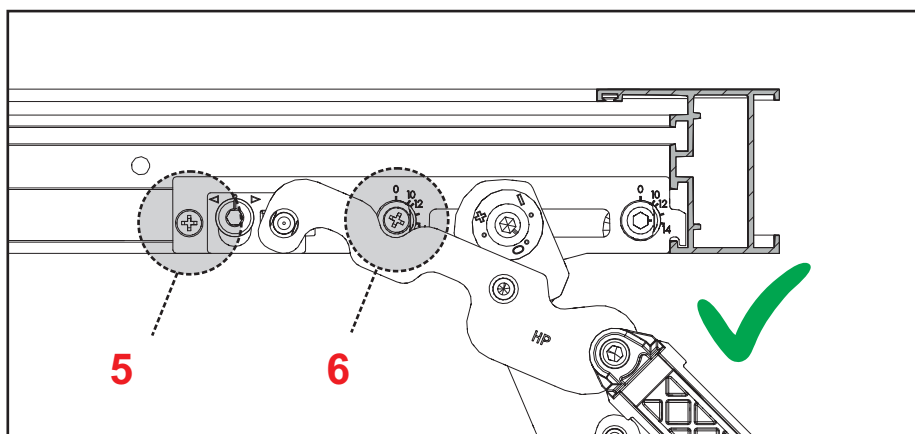
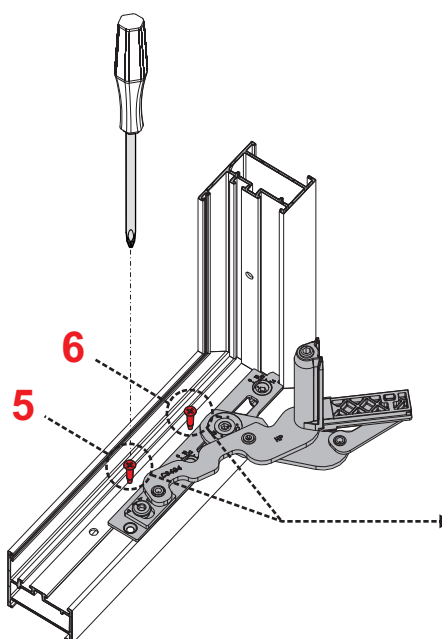
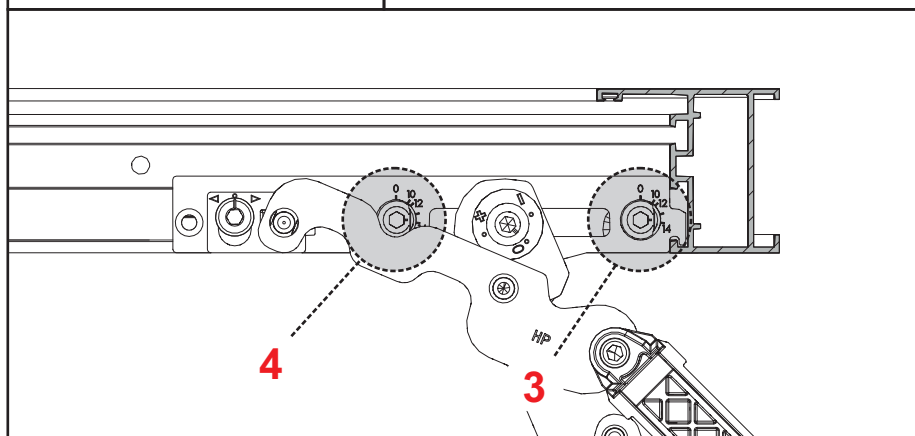
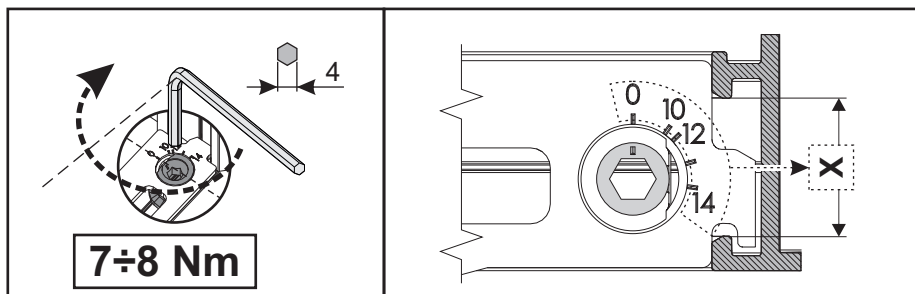
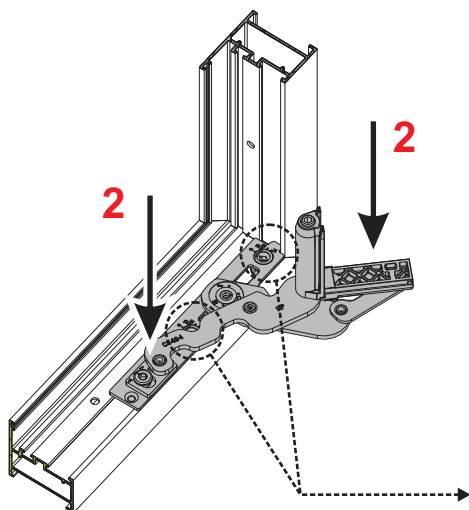
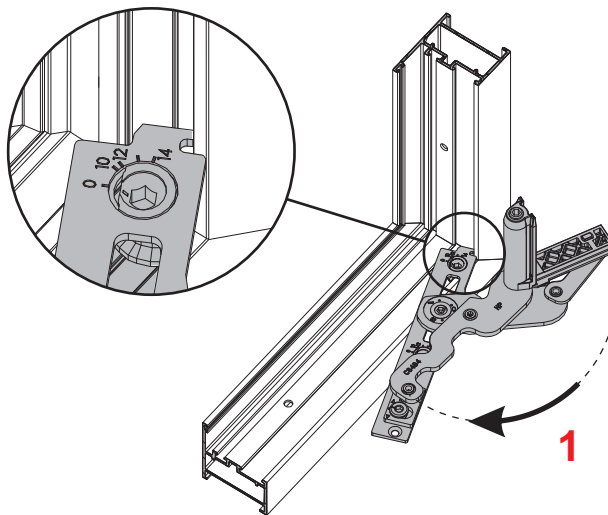

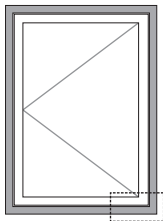

4

A

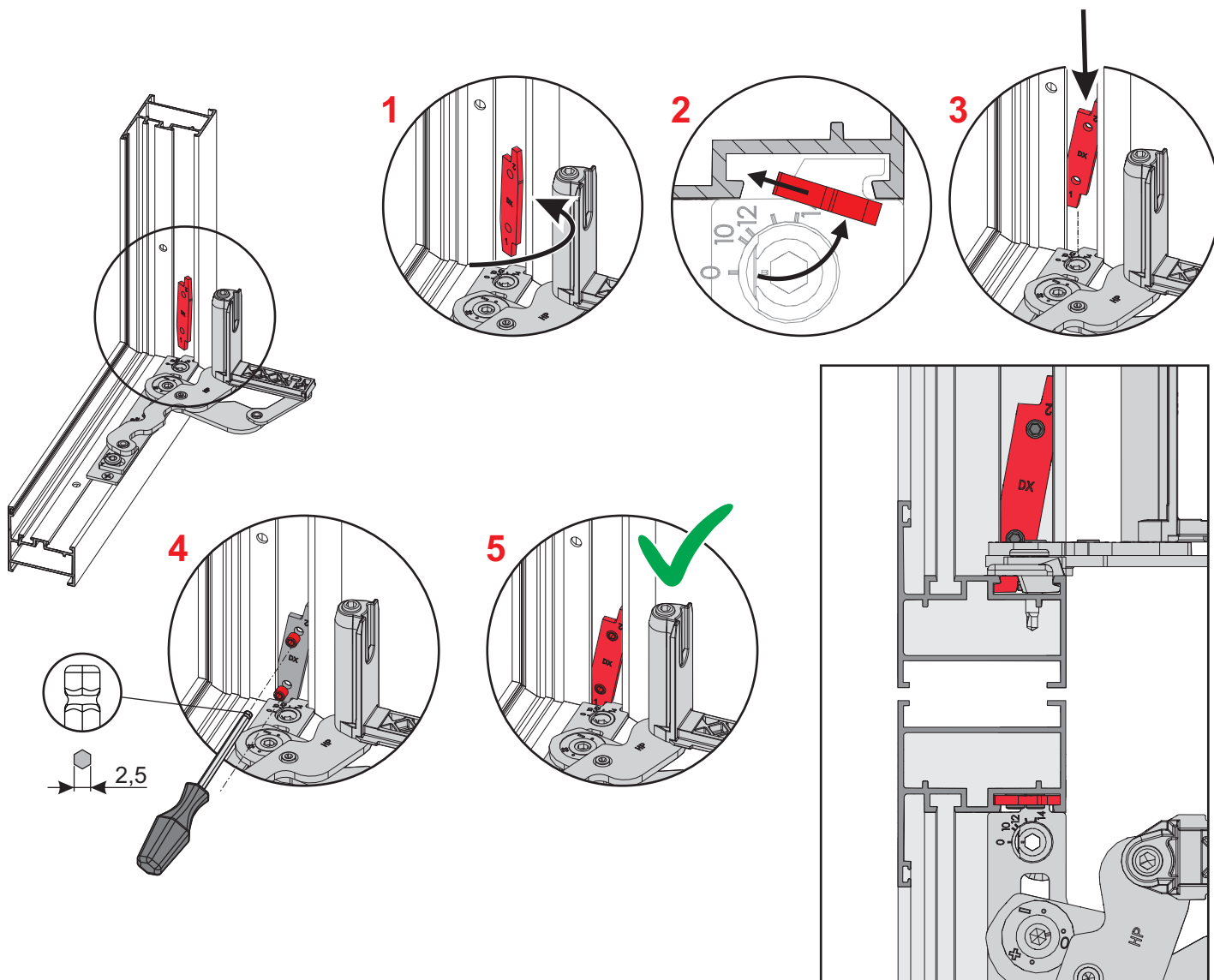
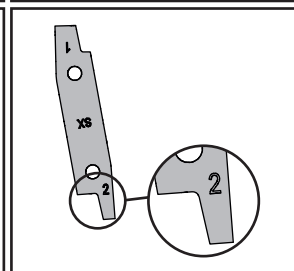
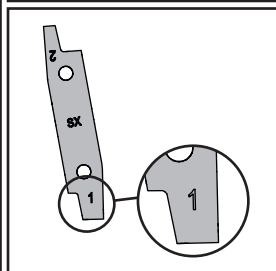
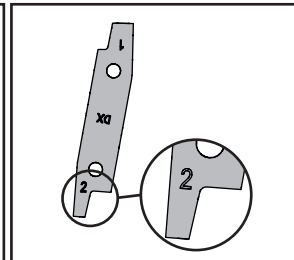
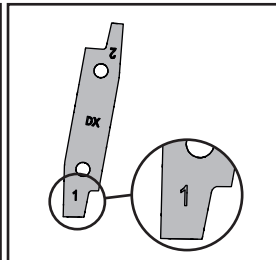
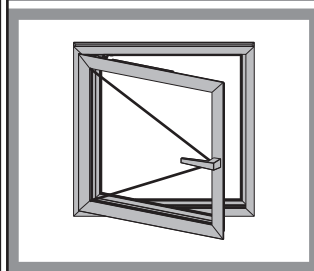
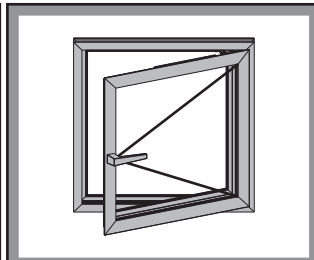
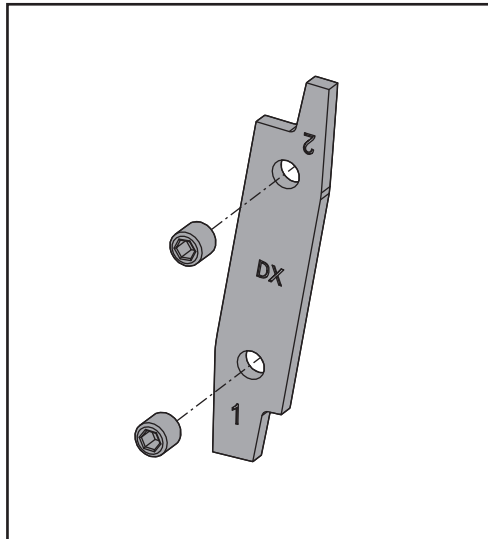
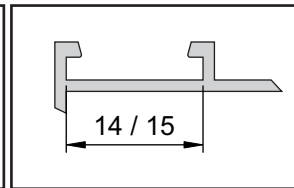
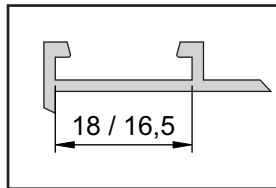

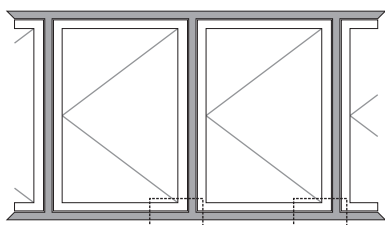

4 

B

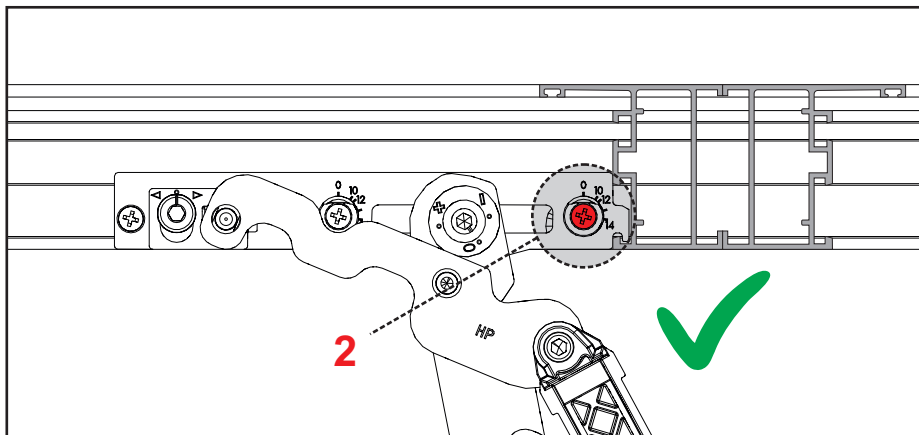
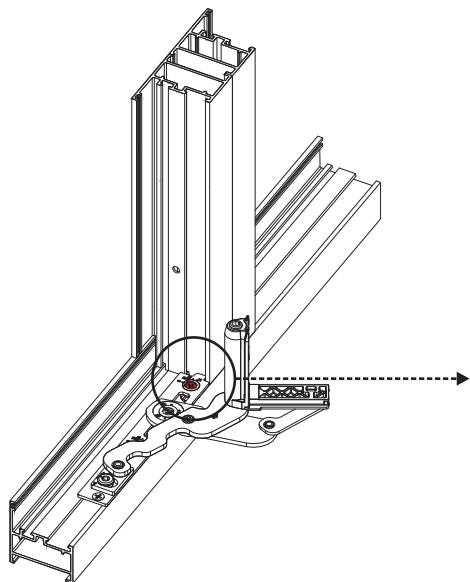
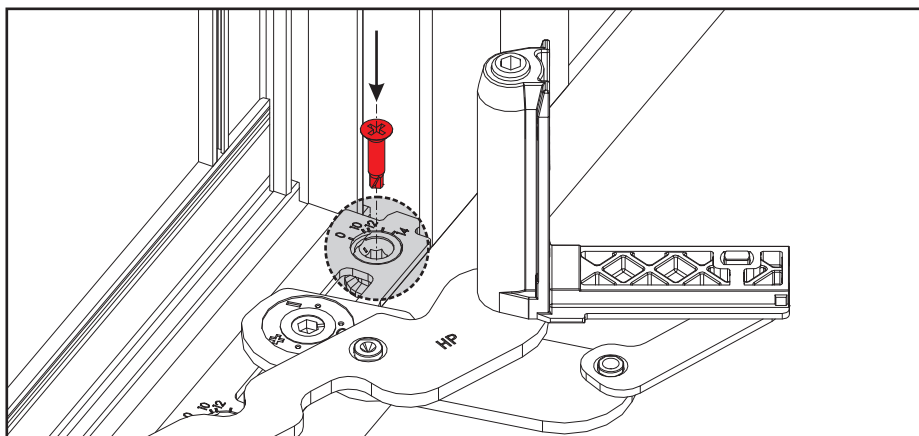
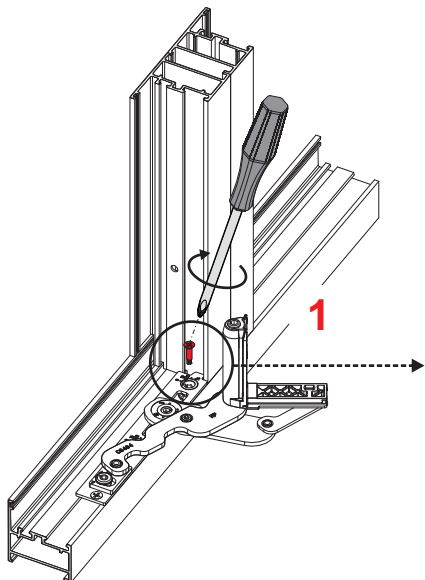
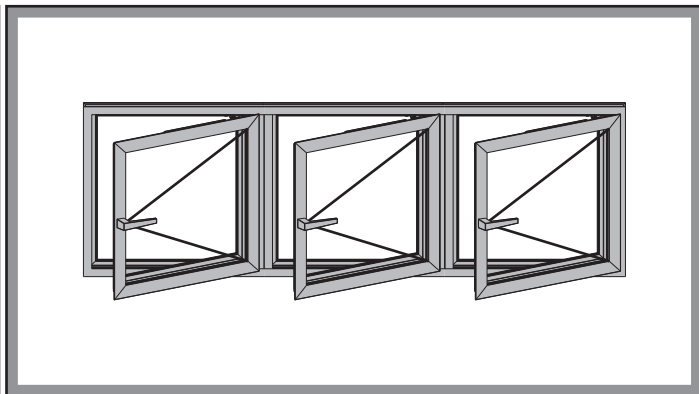
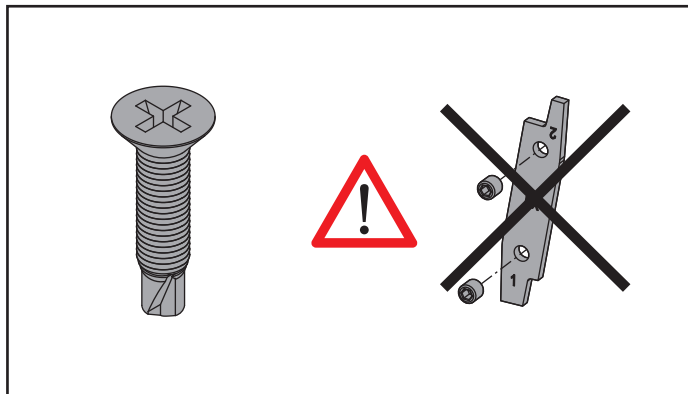

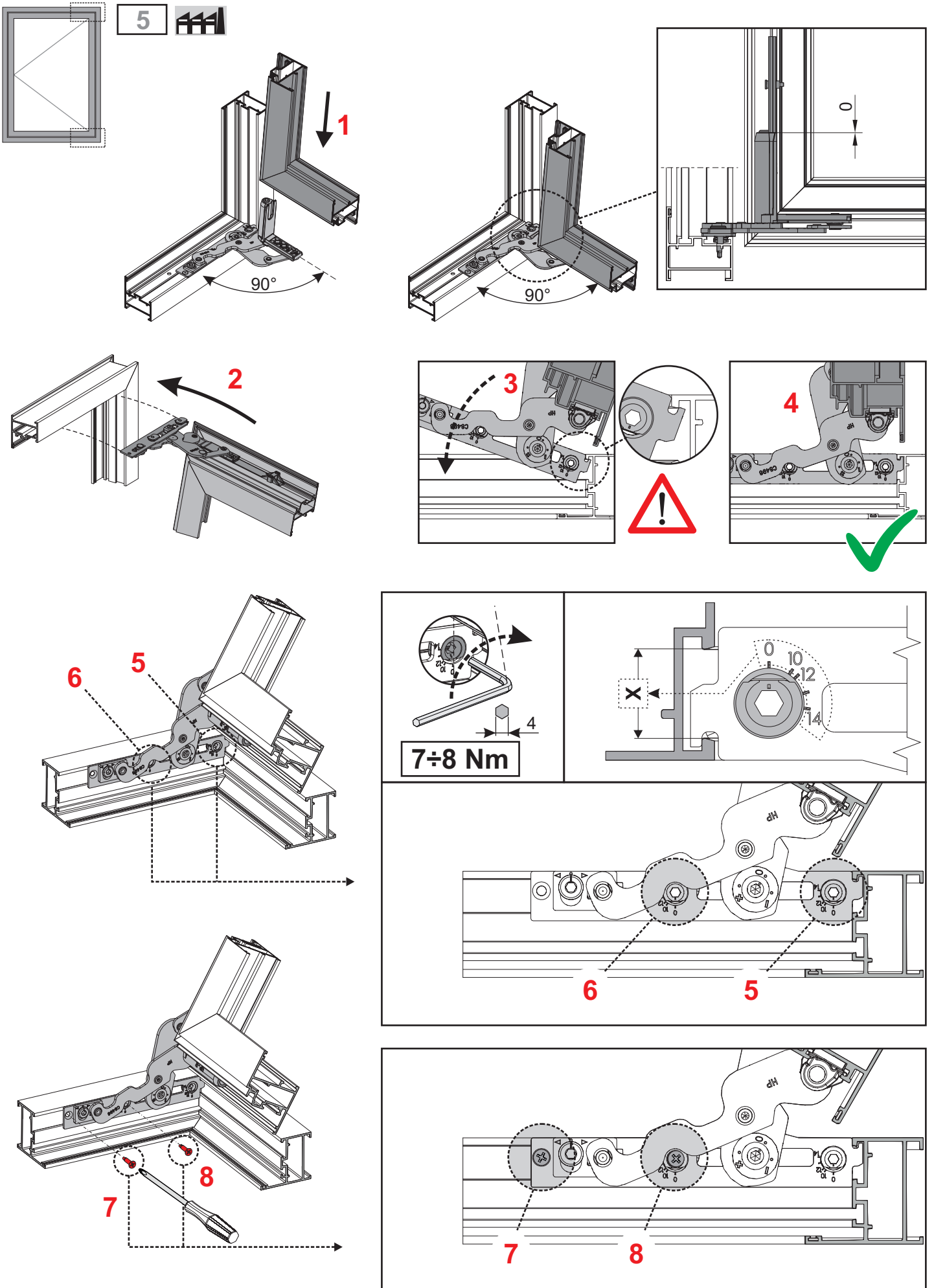

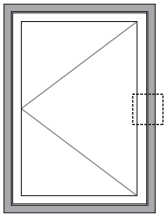

6

