

SPESORE VERNICE
FINISH THICKNESS
PEINTURE ÉPAISSE
ESPEJOR PINTURA
DICKE DER LACKIERUNG

40 ÷ 110 µm

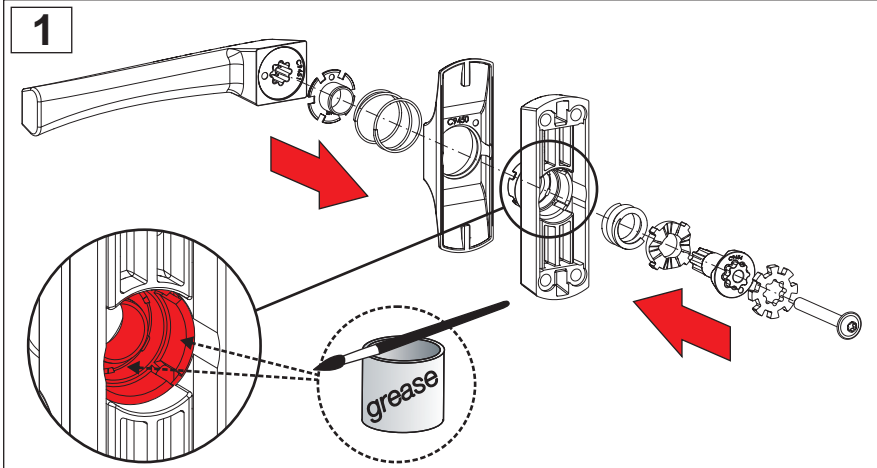
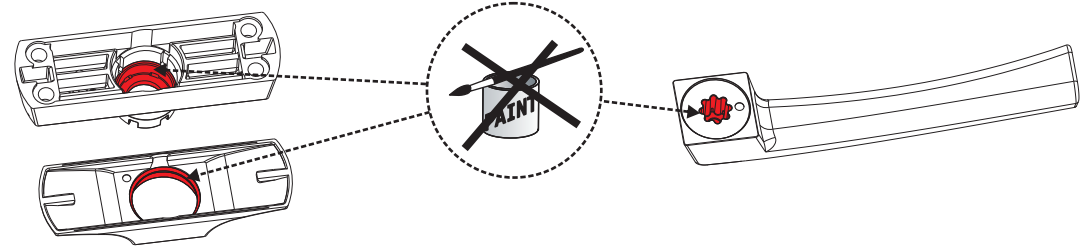

2 **ATTENZIONE:**
 NECESSARIA SPECIFICA MACCHINA E ATTREZZATURA
 DA RICHIEDERE A GIESSE S.P.A.

ATTENTION:
 REQUIRED SPECIFIC MACHINE EQUIPMENT TO
 REQUEST FOR GIESSE S.P.A.

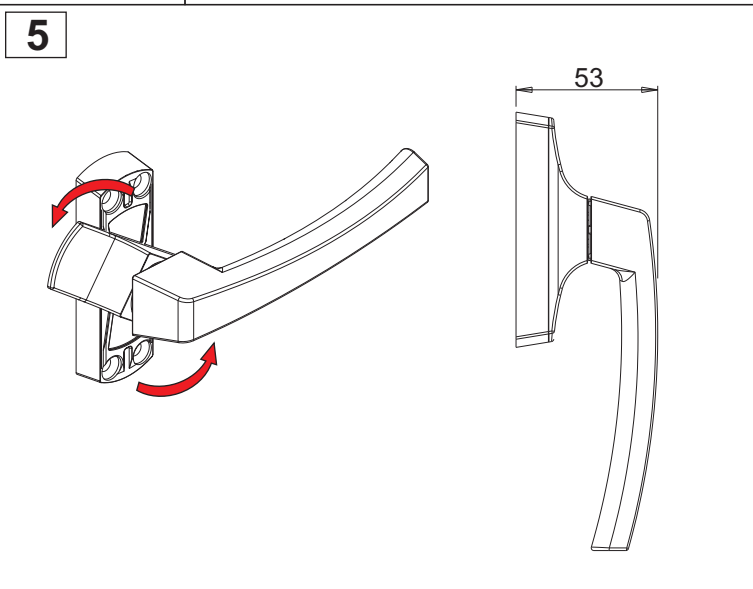
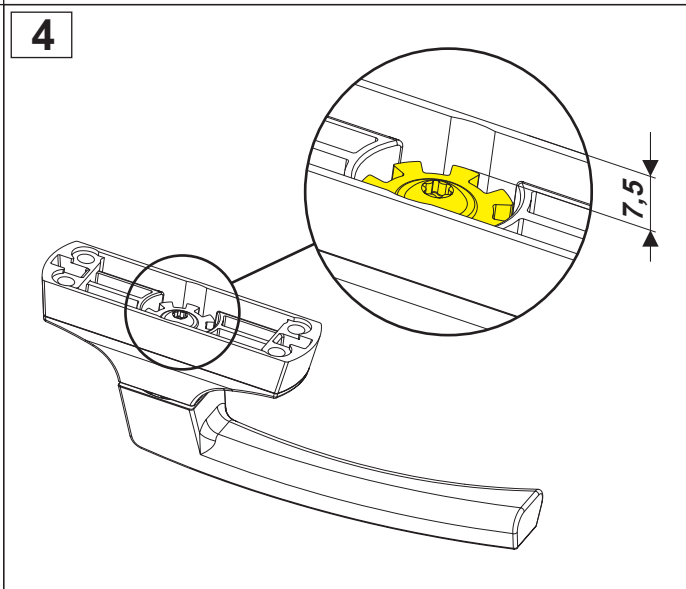
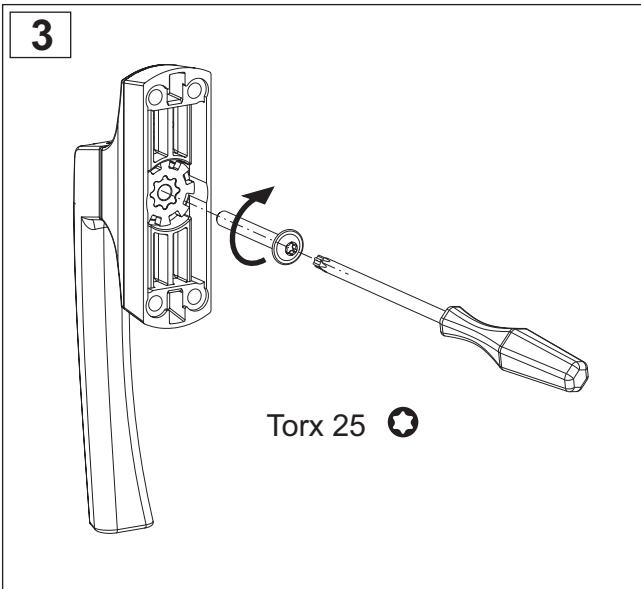
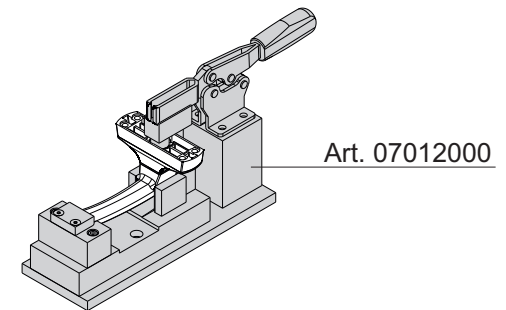

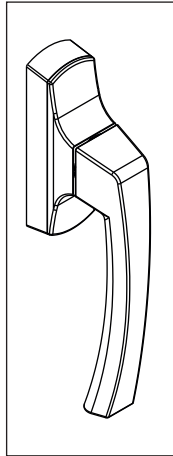

COD.	L
02025000	20 mm
02026000	28 mm
02027000	35 mm
02028000	45 mm
02029000	55 mm
02050000	65 mm

3 S/L

3 D/R

1

2

4

5