

109020030Q/N/09-2023

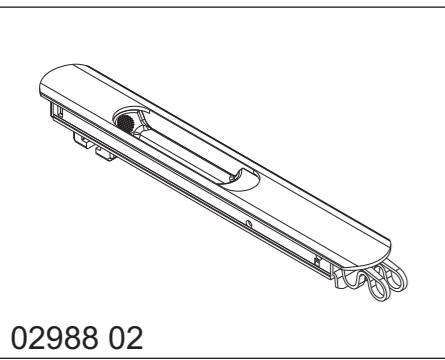

02988 02

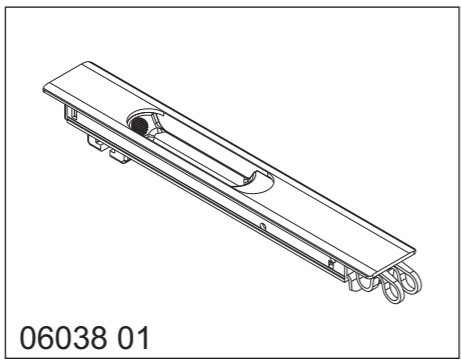

06038 01

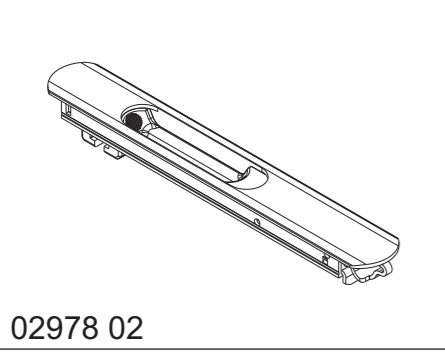

02978 02

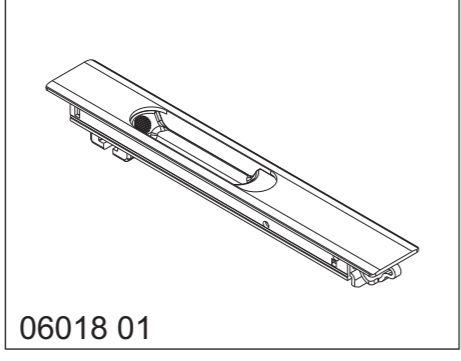

06018 01

KIT AGGANCIAMENTO - COUPLING KIT - KIT DE FERMETURE - KIT GANCHOS - VERRIEGELUNGSKIT

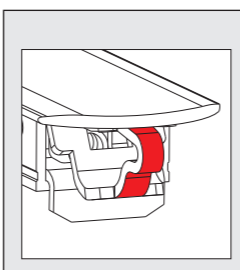

SERIE / SERIES	Y	KIT	Wrench icon
HYDRO - Domal Slide 80	13	04912	45°
HYDRO - Domal Slide 80	13	04918	90°
HYDRO - Domal Slide Pa80	13	04912	45°
HYDRO - Domal Slide Pa110	13	04918	90°
ALCOA - R50S / R50S Revamping	20,5	04894	45°
ALCOA - R50 S	20,5	04895	90°

Wrench icon

45° 90°

TELAIO  
COUNTERFRAME  
DORMANT  
CONTRAMARCO  
BLENDRAHMEN

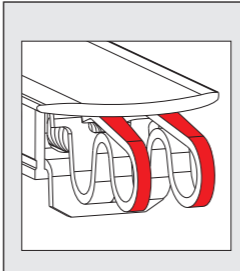

SERIE / SERIES	Y	KIT	Wrench icon
ALCOA - R50S / R50S Revamping	20,5	04894	45°
ALCOA - R50S	20,5	04895	90°
ALCOA - Win65S - 65STT	15,5	04904	45°
ALCOA - Win90S - 90STT (F90S/TT)	15,5	04994	45°
ALLCO - Export 60S	12	04916	45°
ALLCO - Export 60S	22,5	04899	45°
ALLCO - Triall.co 65 - 65TT	16,5	04902	45°
ALLCO - Triall.co 90 - 90TT	16,5	04903	45°
HYDRO - Domal40S	14	04916	45°
HYDRO - Domal Slide 56	28	04896	45°
HYDRO - Domal Slide 84	28	04893	45°

SERIE / SERIES	Y	KIT	Wrench icon
INDINVEST - Alpha 560S	12,5	04916	45°
INDINVEST - Gold 650S - 650STT	16	04902	45°
METRA - NC 60 I	13,5	04888	45°
METRA - NC 60 I	22,5	04888	45°
METRA - NC 90 I	18,5	04900	90°
PASSERINI - Skeit 60	21	04888	45°
PASSERINI - Skeit 60 Super (36, TT)	15,5	03318	45°
PROFILATI - PE 60S	12	04916	45°
PROFILATI - PE 60S	21,5	04899	45°
PROFILATI - PE 70S - 70STT	15	04904	45°

- ⊗ Sulla serie R50 S la Maniglia Brio è applicabile solo realizzando l'asola squadrata e non quella stondata.
- ⊗ On the R50 S series the Brio handle can only be applied by machining the square-corner slot and not the rounded-corner slot.
- ⊗ Pour la série R50 S, il est nécessaire de pratiquer le trou oblong carré et non le trou arrondi pour pouvoir appliquer la cuvette Brio.
- ⊗ En la serie R50 S la Manilla Brio puede aplicarse sólo realizando el mecanizado escuadrado y no el redondeado.
- ⊗ Bei der Serie R50 S kann die Griffmuschel Brio nur montiert werden, wenn der eckige Schlitz und nicht der abgerundete Schlitz hergestellt wird.

LAVORAZIONE MONTANTE CONTROTELAIO  
WORKING JAMBS COUNTER-FRAMES  
TRAVAIL MONTANT PROFIL DORMANT  
TRABAJO MONTANTE MARCO  
BLENDRAHMENBEARBEITUNG

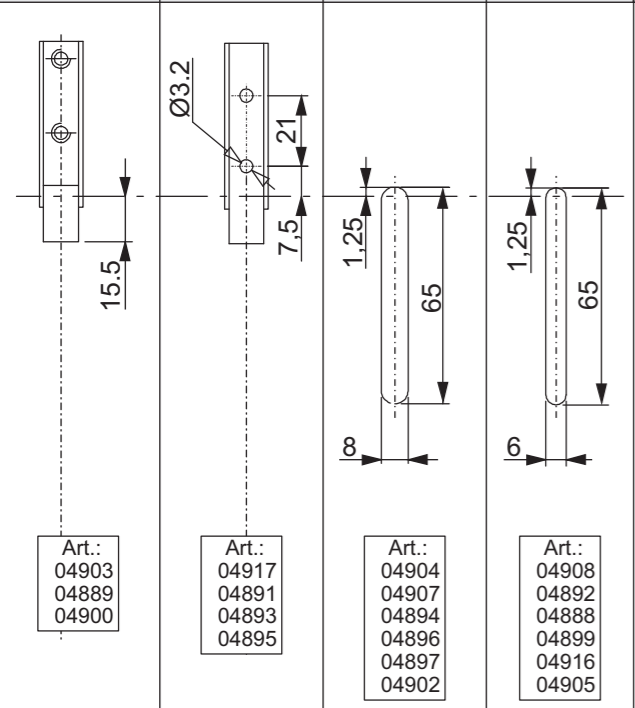

LAVORAZIONE MONTANTE ANTA  
WORKING JAMBS WING  
TRAVAIL MONTANT  
TRABAJO MONTANTE HOJA  
FLÜGELBEARBEITUNG

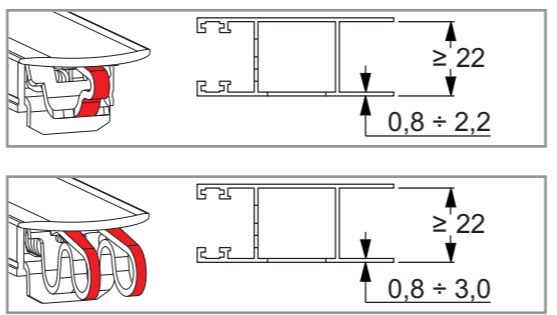
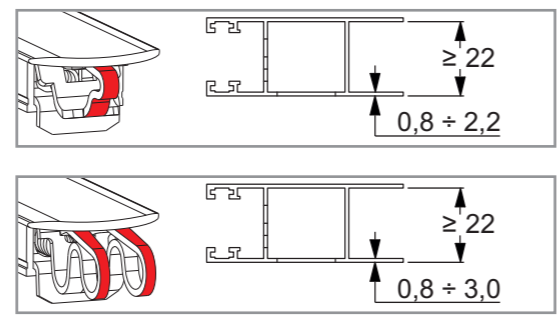
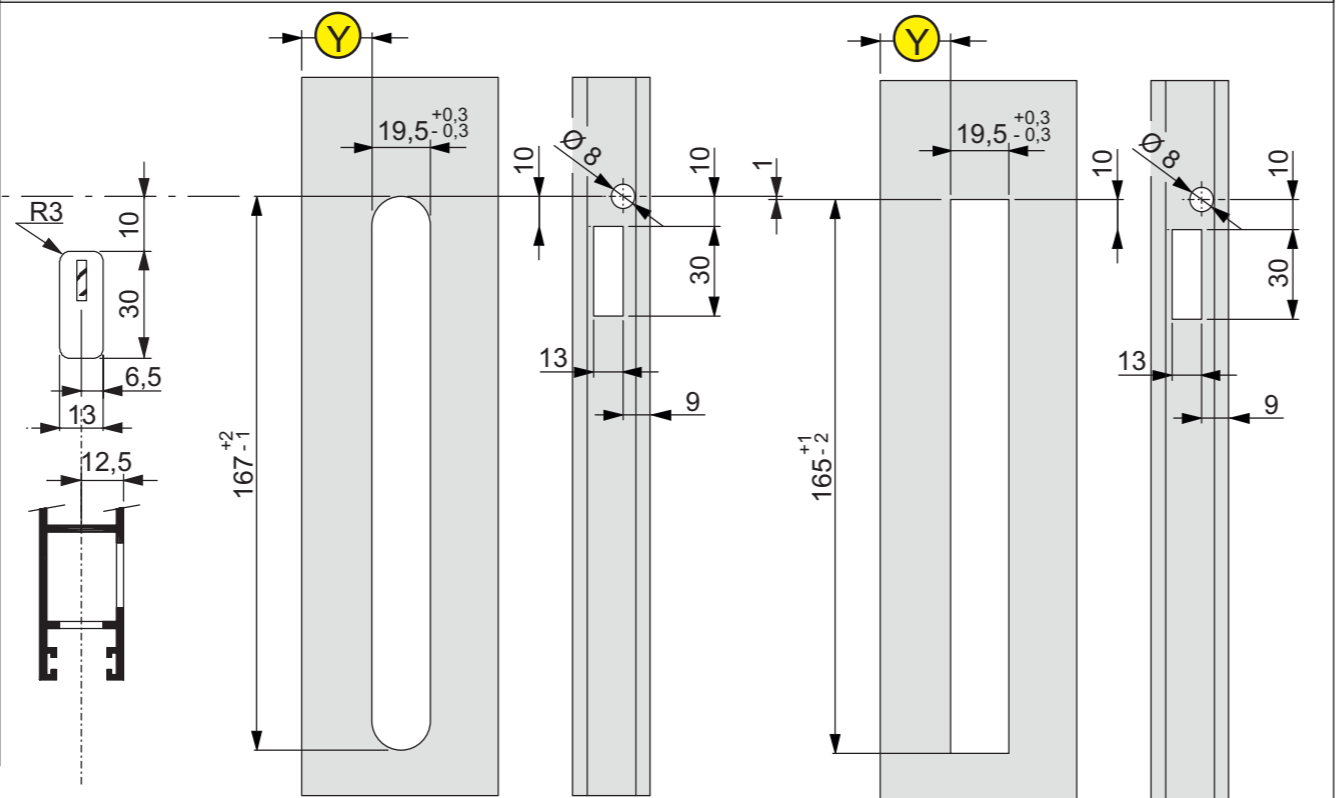

Asse centrale binario  
Axe central rail  
Axe voie centrale  
Eje central binario  
Mittelachse der Schiene

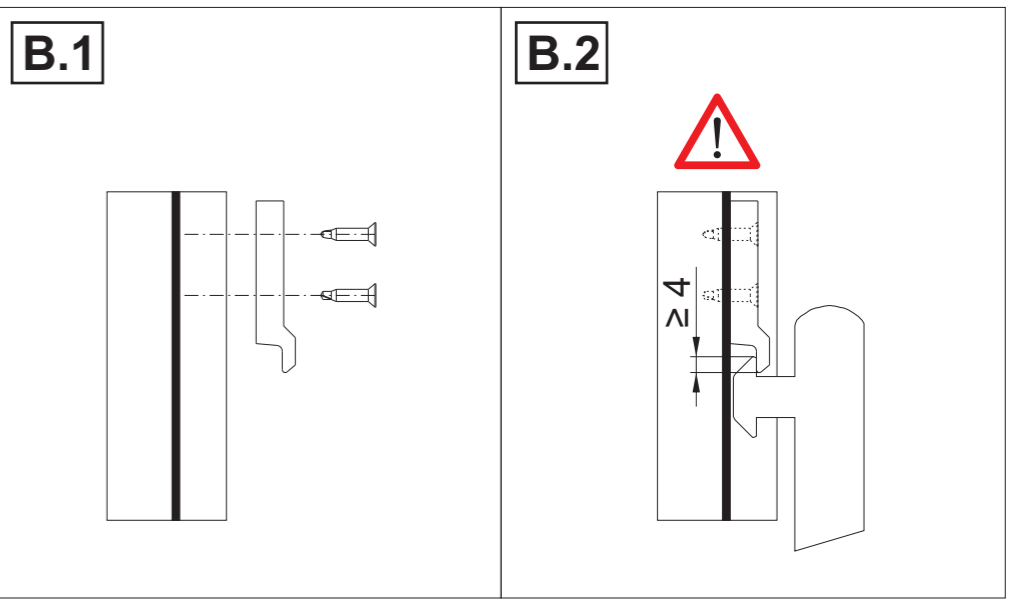
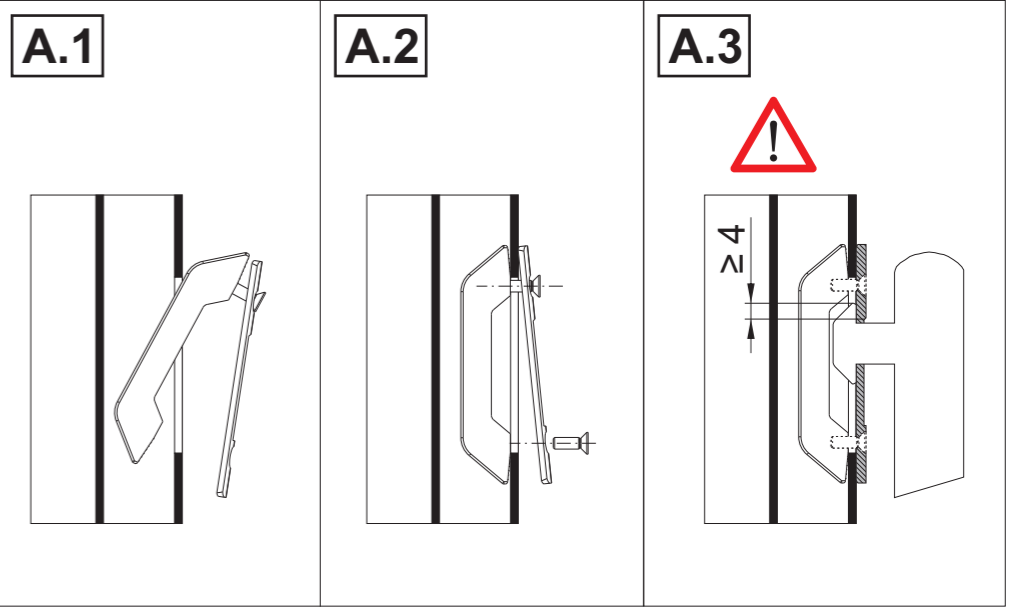

1

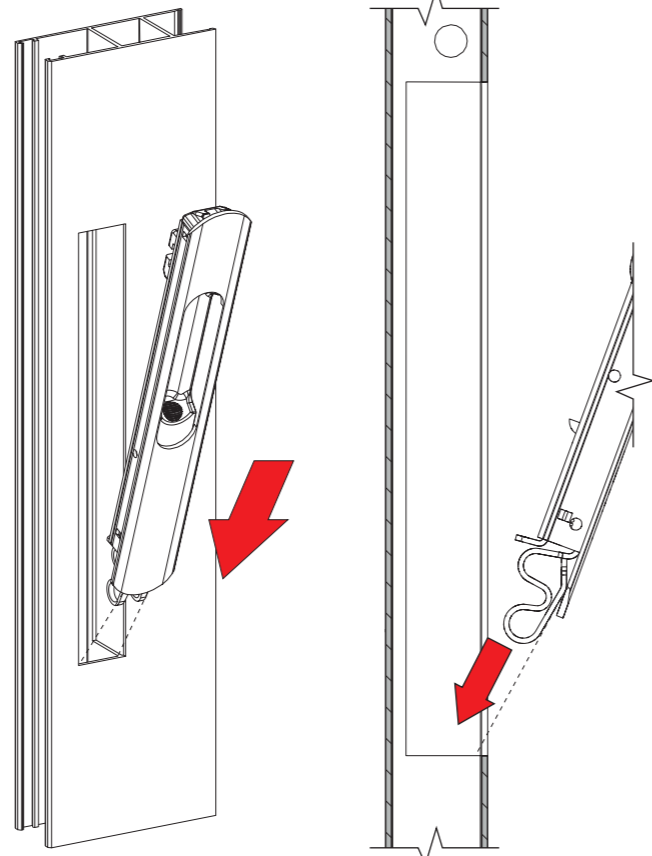
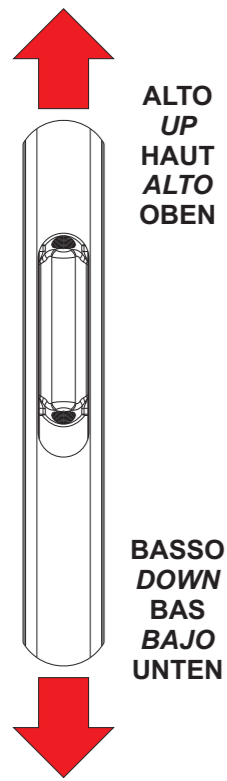

2

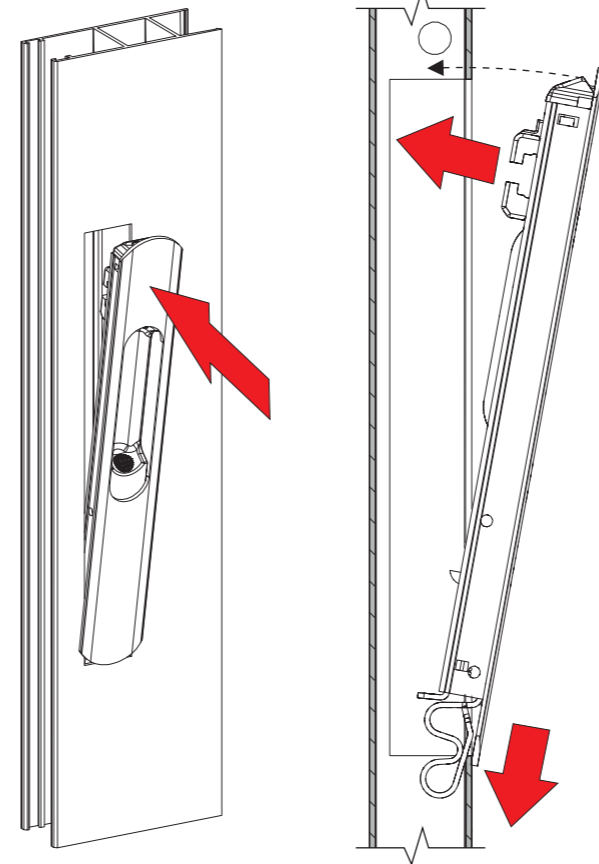

3

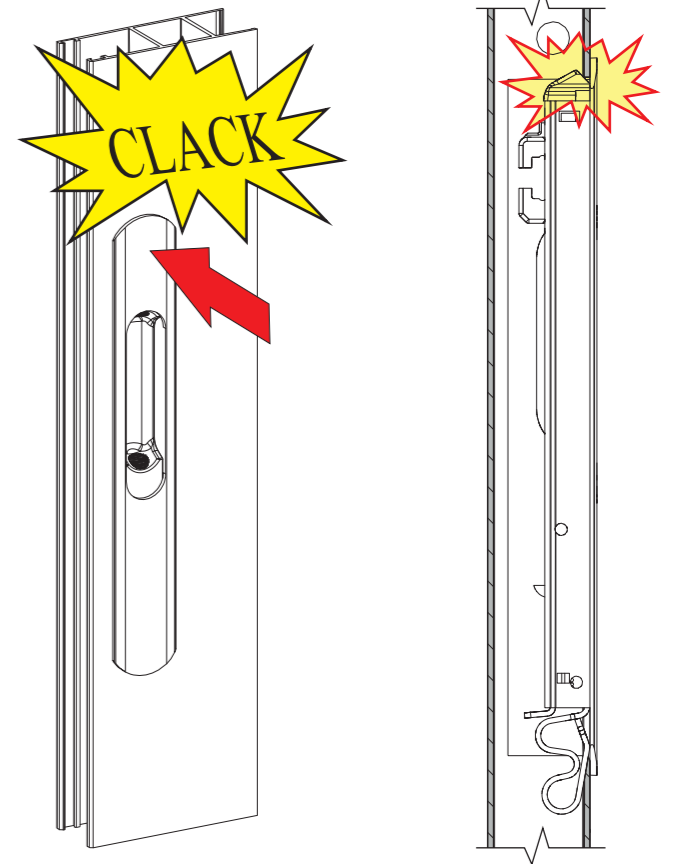

4

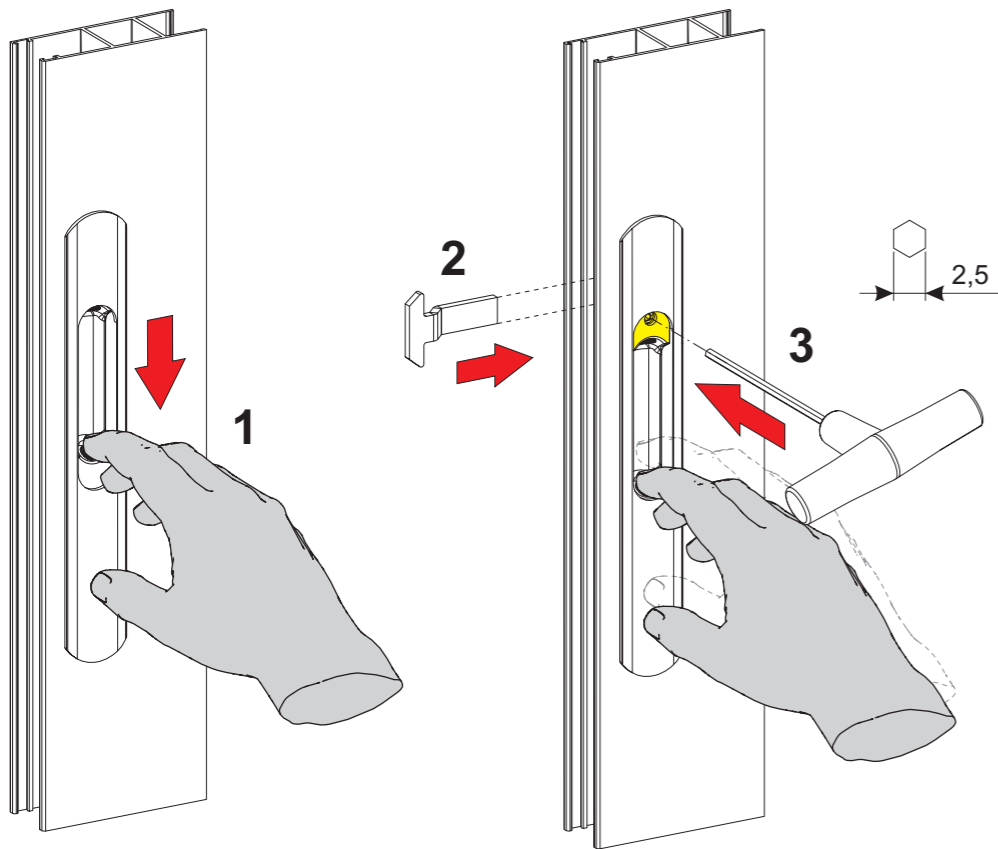

5

