

109280000QNI/06-2019

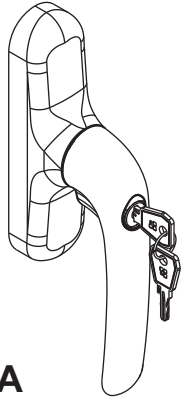

PRIMA

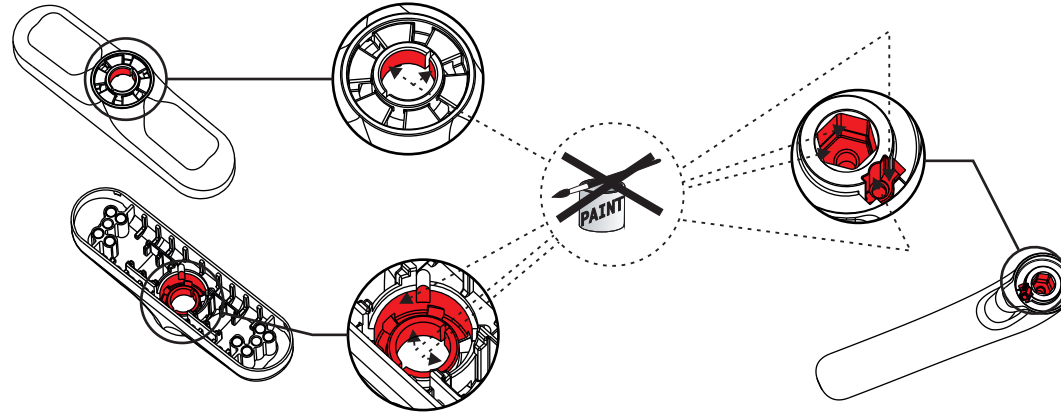

SPESORE VERNICE  
FINISH THICKNESS  
PEINTURE ÉPAISSE  
ESPESOR PINTURA  
DICKE DER LACKIERUNG  
40 ÷ 110 µm



ATTENZIONE:  
NECESSARIA SPECIFICA  
MACCHINA E ATTREZZATURA

ATTENTION:  
REQUIRED SPECIFIC MACHINE  
EQUIPMENT

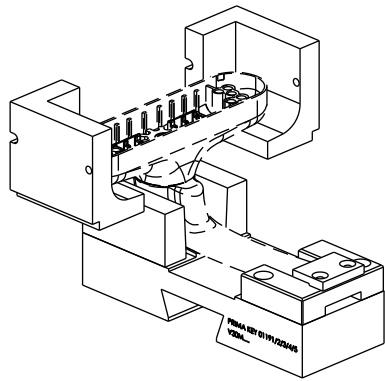

1

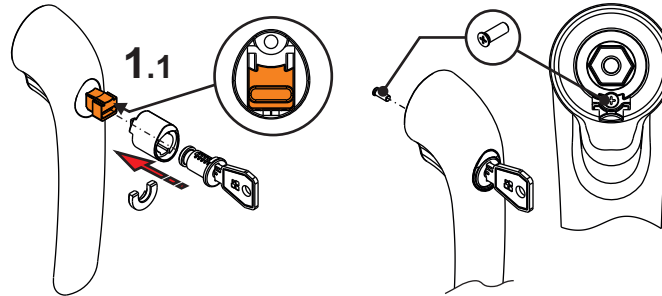
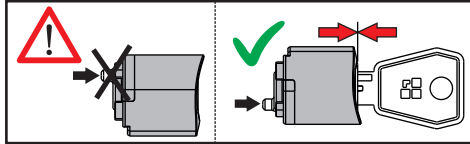

2

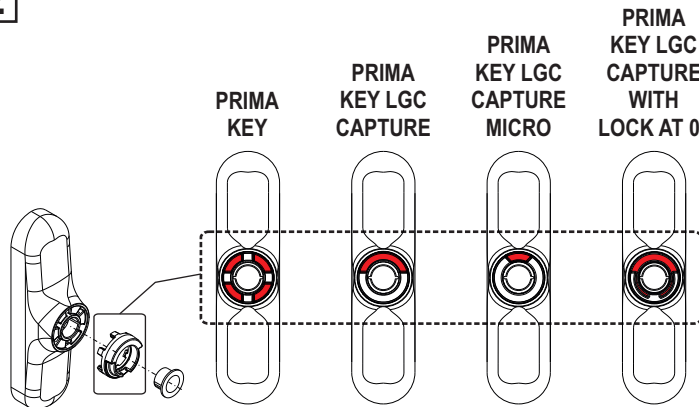

3

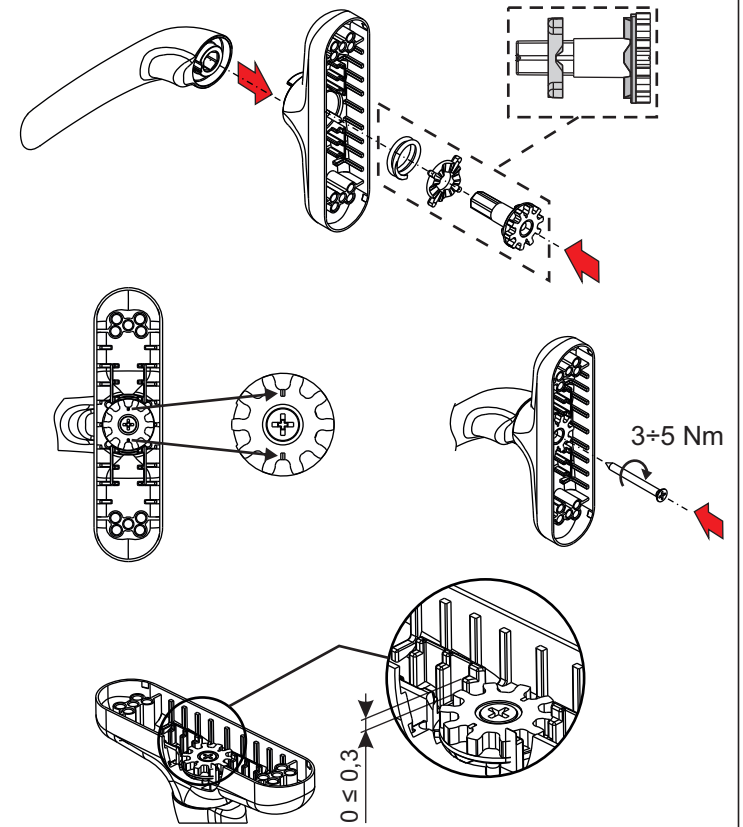

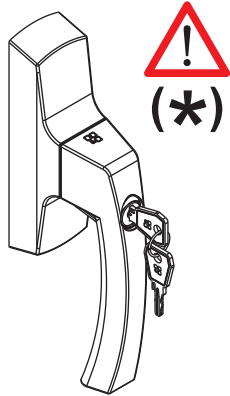

ASIA

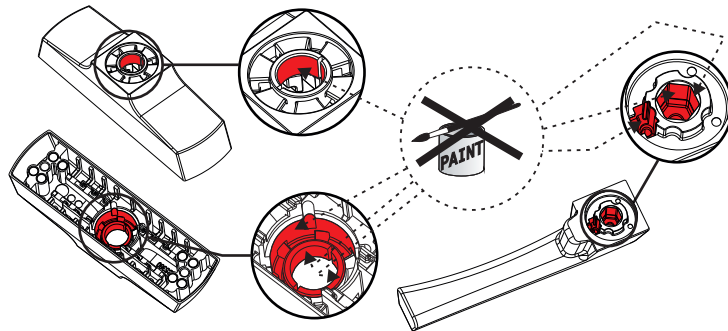

SPESSORE VERNICE - FINISH THICKNESS  
 PEINTURE ÉPAISSE - ESPESOR PINTURA  
 DICKE DER LACKIERUNG  $40 \div 110 \mu\text{m}$

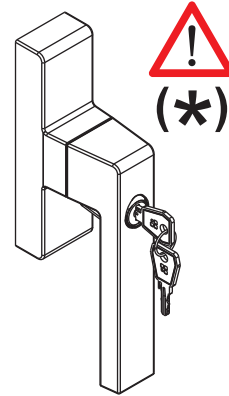

KORA

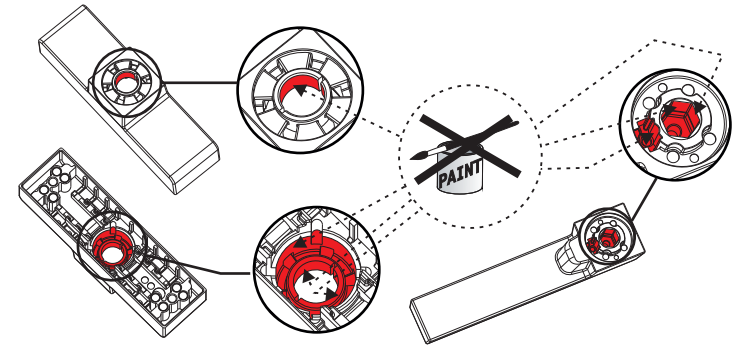

SPESSORE VERNICE - FINISH THICKNESS  
 PEINTURE ÉPAISSE - ESPESOR PINTURA  
 DICKE DER LACKIERUNG  $40 \div 110 \mu\text{m}$

1

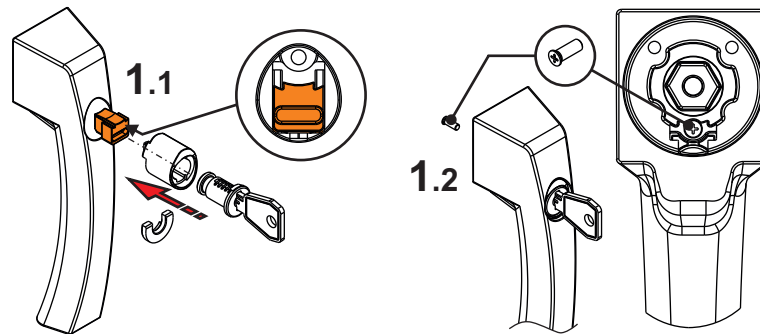
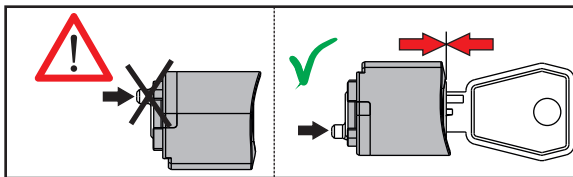

3

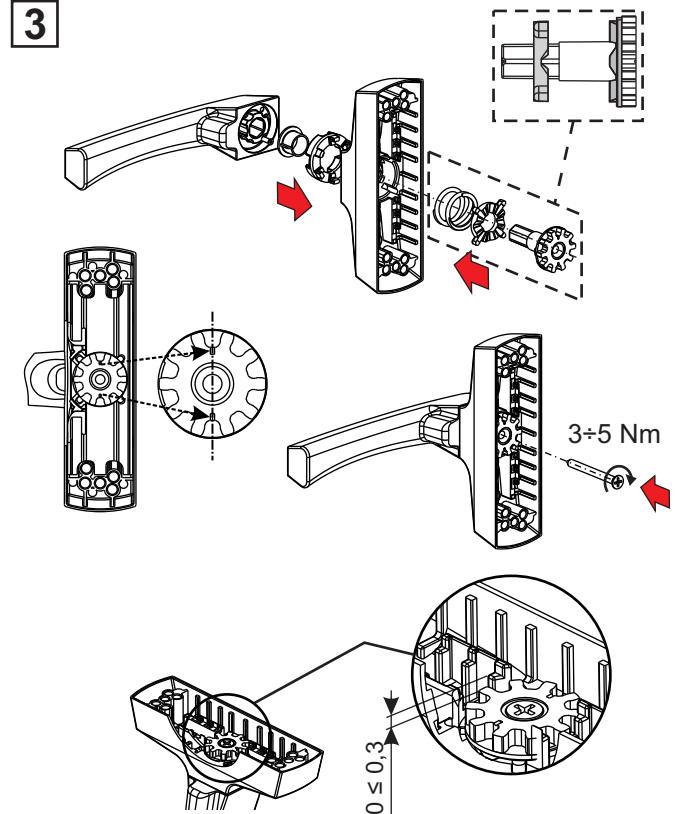

ATTENZIONE:  
 NECESSARIA SPECIFICA MACCHINA E  
 ATTREZZATURA

ATTENTION:  
 REQUIRED SPECIFIC MACHINE EQUIPMENT

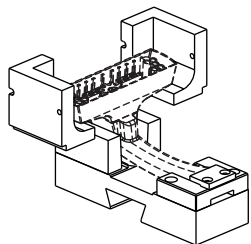

2

