

KIT AGGANCIO – COUPLING KIT – KIT DE FERMETURE – KIT GANCHOS – VERRIEGELUNGSKIT

SERIE / SERIES	Y	KIT	Wrench icon
DOMAL HYDRO BUILDING SYSTEM IT - Slide 80	13	04912L1	45°
DOMAL HYDRO BUILDING SYSTEM IT - Slide Pa80	13	04912L1	45°
ORIGINAL SYSTEM HYDRO BUILDING - R50S / R50S Revamping	20,5	0489401	45°
ORIGINAL SYSTEM HYDRO BUILDING - R50S	20,5	0489501	90°

45° 90°

TELAIO
COUNTERFRAME
DORMANT
CONTRAMARCO
BLENDRAHMEN

SERIE / SERIES	Y	KIT	Wrench icon
ORIGINAL SYSTEM HYDRO BUILDING - R50S / R50S Revamping	20,5	0489401	45°
ORIGINAL SYSTEM HYDRO BUILDING - R50S	20,5	0489501	90°
ORIGINAL SYSTEM HYDRO BUILDING - Win65S - 65STT	15,5	0490401	45°
ORIGINAL SYSTEM HYDRO BUILDING - Win90S - 90STT (F90S/TT)	15,5	04994L1	45°
ALLCO - Export 60S	12	0491601	45°
ALLCO - Export 60S	22,5	0489901	45°
ALLCO - Triall.co 65 - 65TT	16,5	0490201	45°
ALLCO - Triall.co 90 - 90TT	16,5	0490301	45°
DOMAL HYDRO BUILDING SYSTEM IT - Domal40S	14	0491601	45°
DOMAL HYDRO BUILDING SYSTEM IT - Slide 56	28	0489601	45°
DOMAL HYDRO BUILDING SYSTEM IT - Slide 84	28	0489301	45°
INDINVEST - Gold 650S - 650STT	16	0490201	45°
PROFILATI - PE 60 Slide	12	0491601	45°
PROFILATI - PE 70 Slide - 70 Slide TT	15	0490401	45°

- ⊗ Sulla serie R50 S la Maniglia Brio è applicabile solo realizzando l'asola squadrata e non quella stondata.
- ⊗ On the R50 S series the Brio handle can only be applied by machining the square-corner slot and not the rounded-corner slot.
- ⊗ Pour la série R50 S, il est nécessaire de pratiquer le trou oblong carré et non le trou arrondi pour pouvoir appliquer la cuvette Brio.
- ⊗ En la serie R50 S la Manilla Brio puede aplicarse sólo realizando el mecanizado escuadrado y no el redondeado.
- ⊗ Bei der Serie R50 S kann die Griffmuschel Brio nur montiert werden, wenn der eckige Schlitz und nicht der abgerundete Schlitz hergestellt wird.

LAVORAZIONE MONTANTE CONTROTELAIO - WORKING JAMBS COUNTER-FRAMES - TRAVAIL MONTANT PROFIL DORMANT - TRABAJO MONTANTE MARCO - BLENDRAHMENBEARBEITUNG

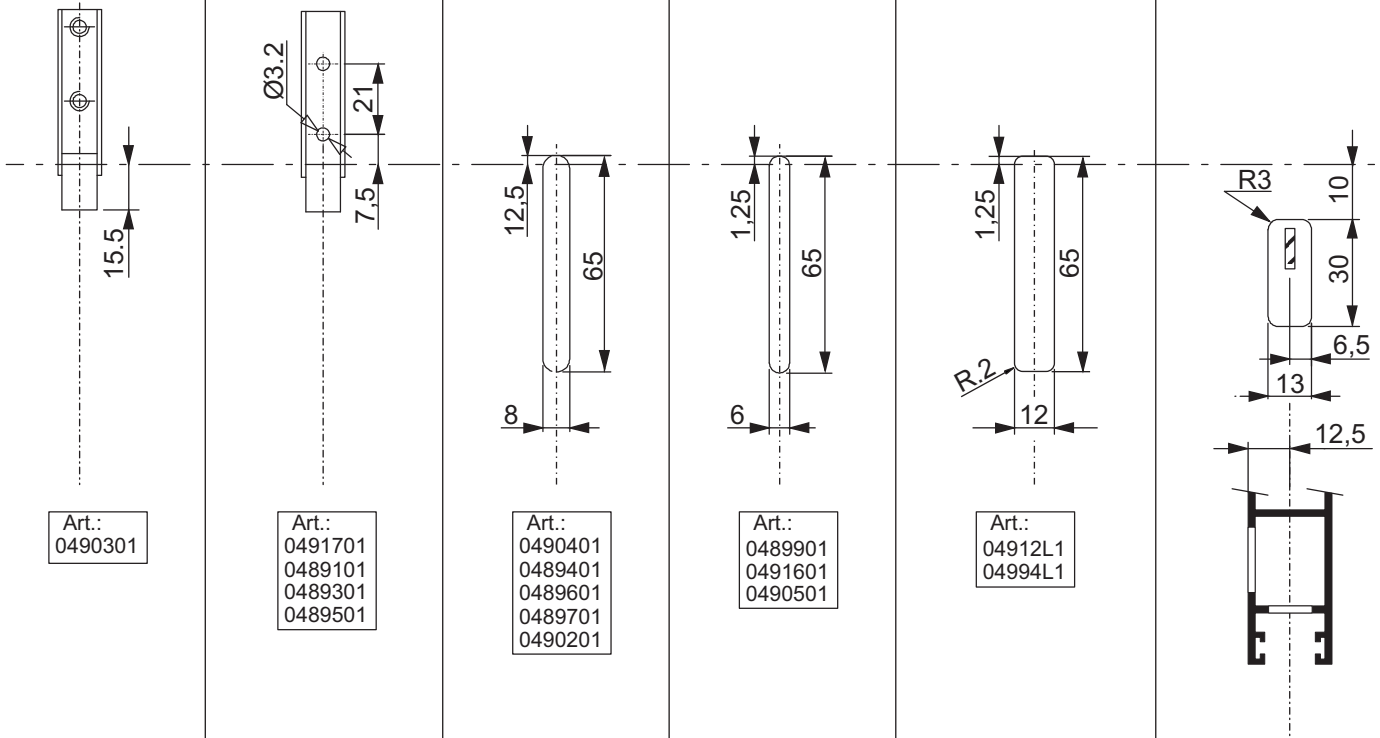

Asse centrale binario
 Axe central rail
 Axe voie centrale
 Eje central binario
 Mittelachse der Schiene

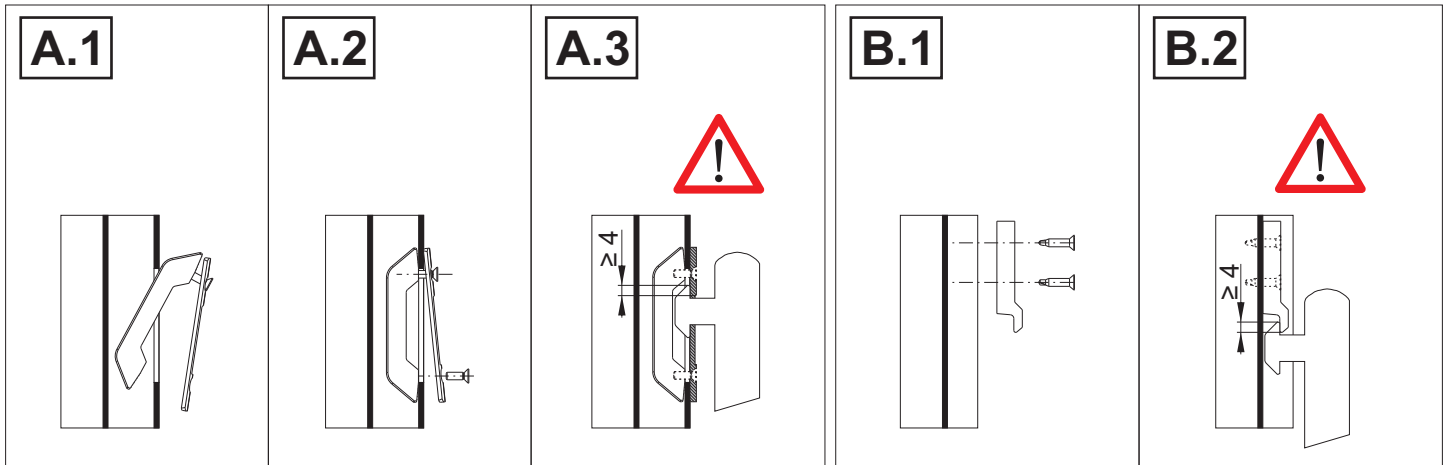

LAVORAZIONE MONTANTE ANTA - WORKING JAMBS WING - TRAVAIL MONTANT - TRABAJO MONTANTE HOJA - FLÜGELBEARBEITUNG

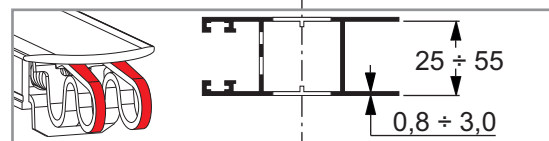
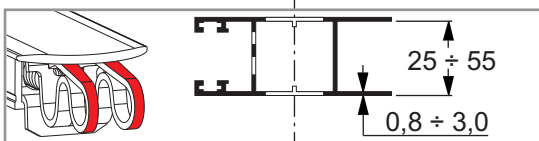
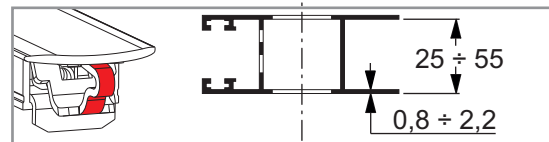
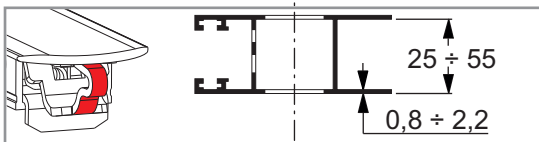
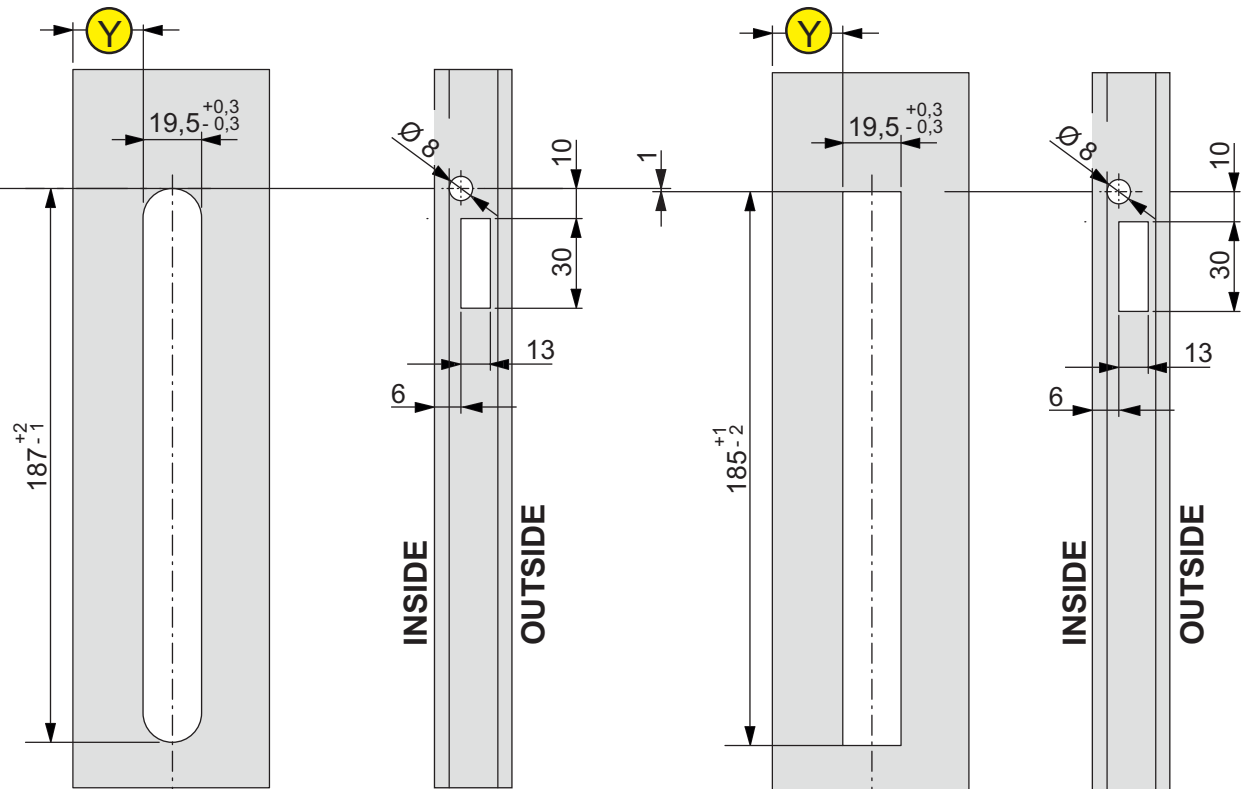

1

Lt = 55 - Sp

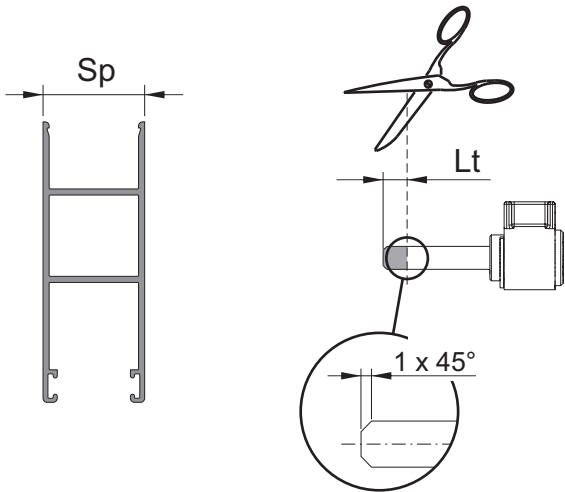

2 A

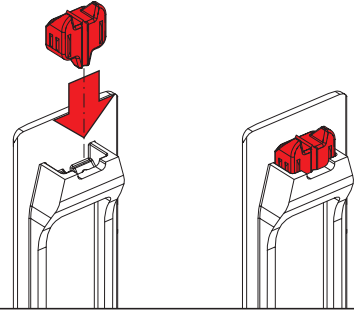

2 B

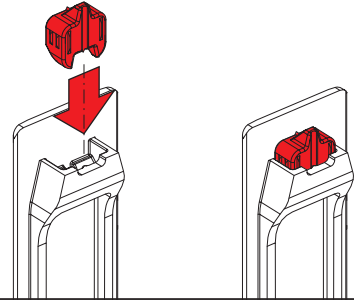

3

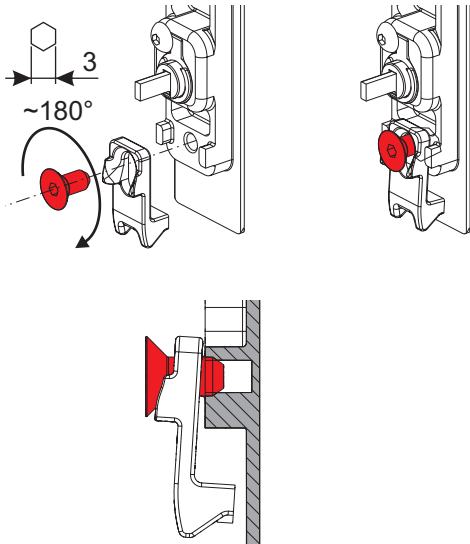

4

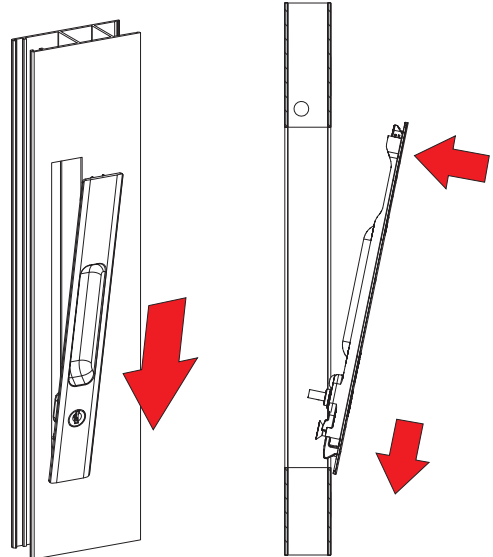

5

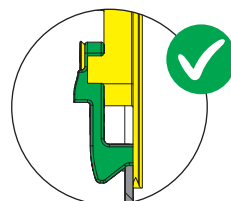
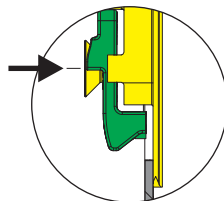
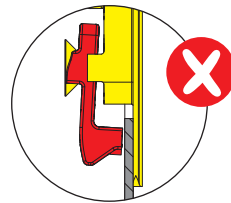
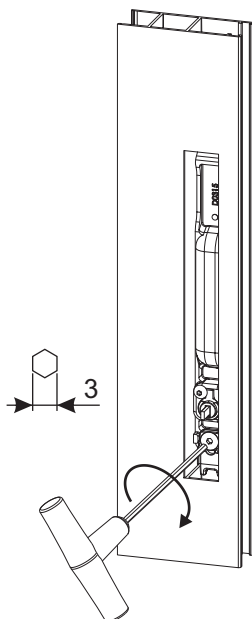

↑
ALTO
TOP
HAUT
ALTO
OBEN

↓
BASSO
BOTTOM
BAS
BAJO
UNTEN

6

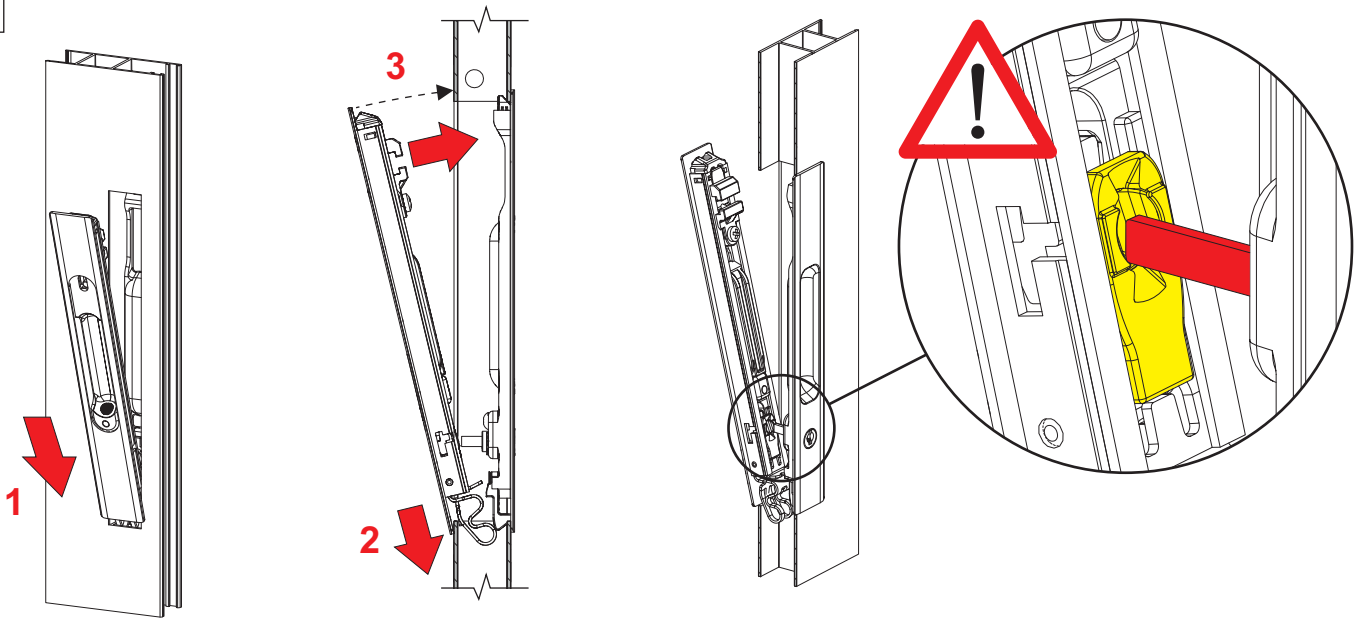

7

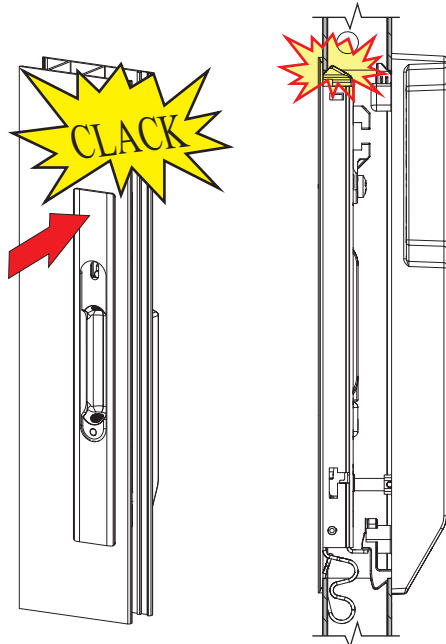

8

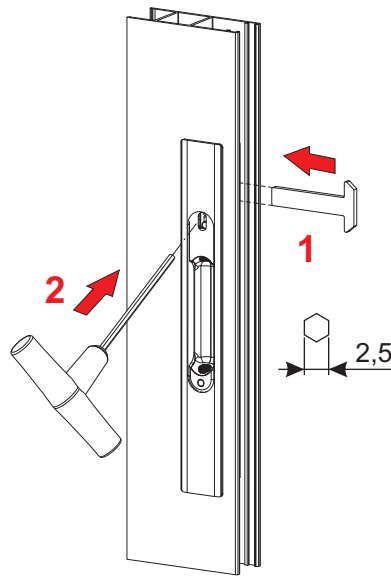

9

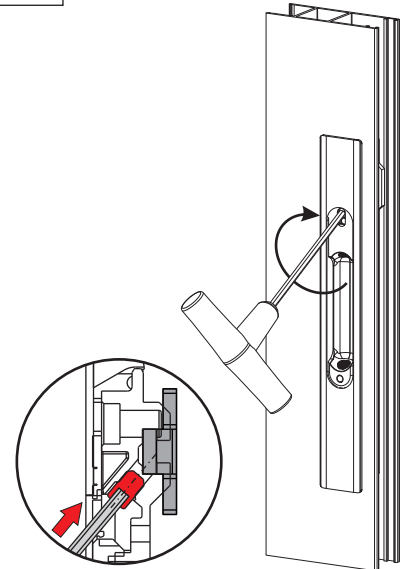

10

