

11129000Q/N/02-2024

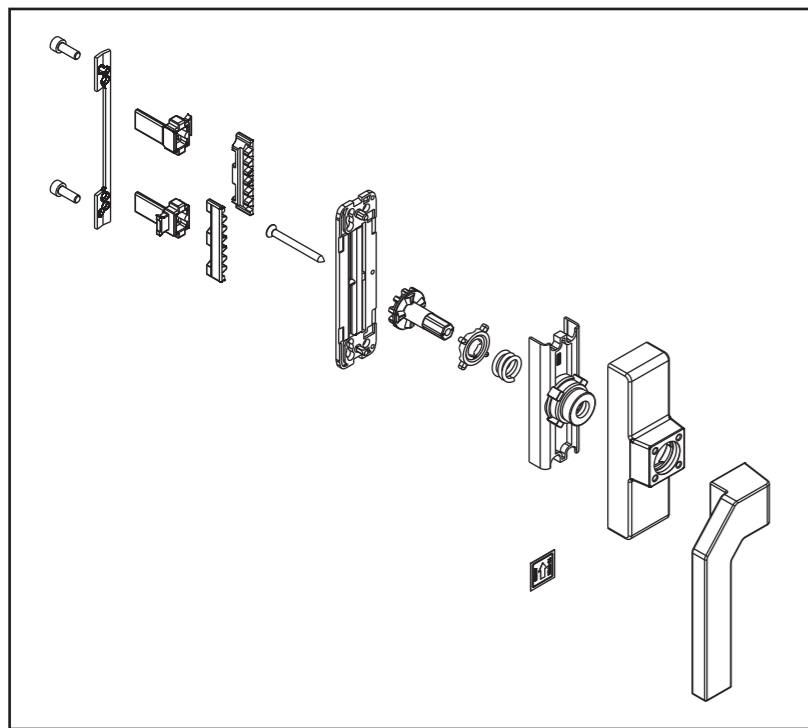

**ATTENZIONE:**  
NECESSARIA  
SPECIFICA MACCHINA  
E ATTREZZATURA DA  
RICHIEDERE A  
GIESSE S.P.A

**ATTENTION:**  
REQUIRED SPECIFIC  
MACHINE EQUIPMENT  
TO REQUEST FOR  
GIESSE S.P.A

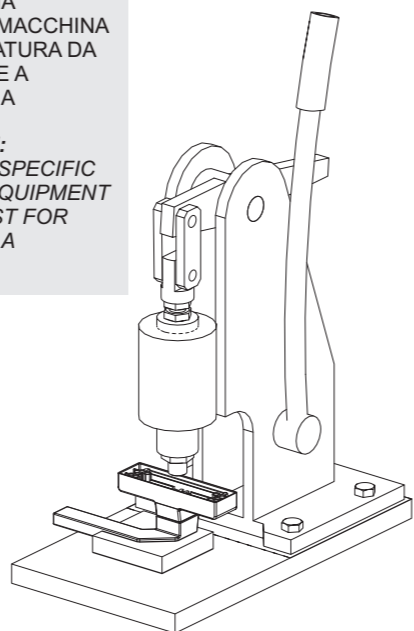

**SPESORE VERNICE**  
**FINISH THICKNESS**  
**PEINTURE ÉPAISSE**  
**ESPEJOR PINTURA**  
**DICKE DER LACKIERUNG**

**40 ÷ 110 µm**

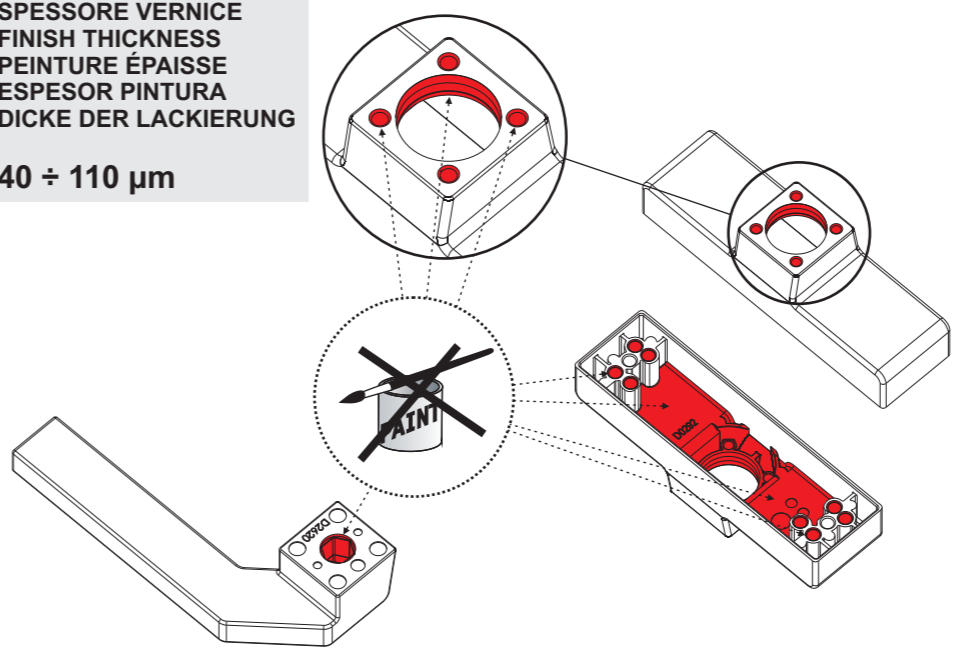

**1**

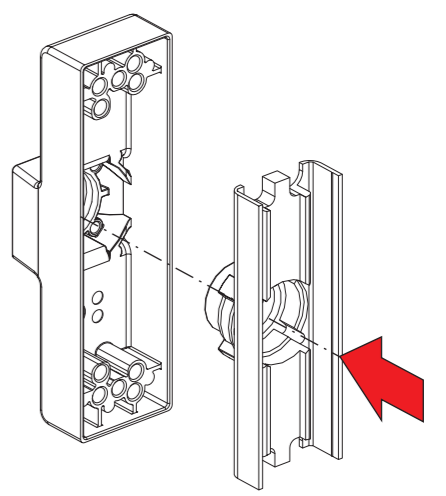

**2**

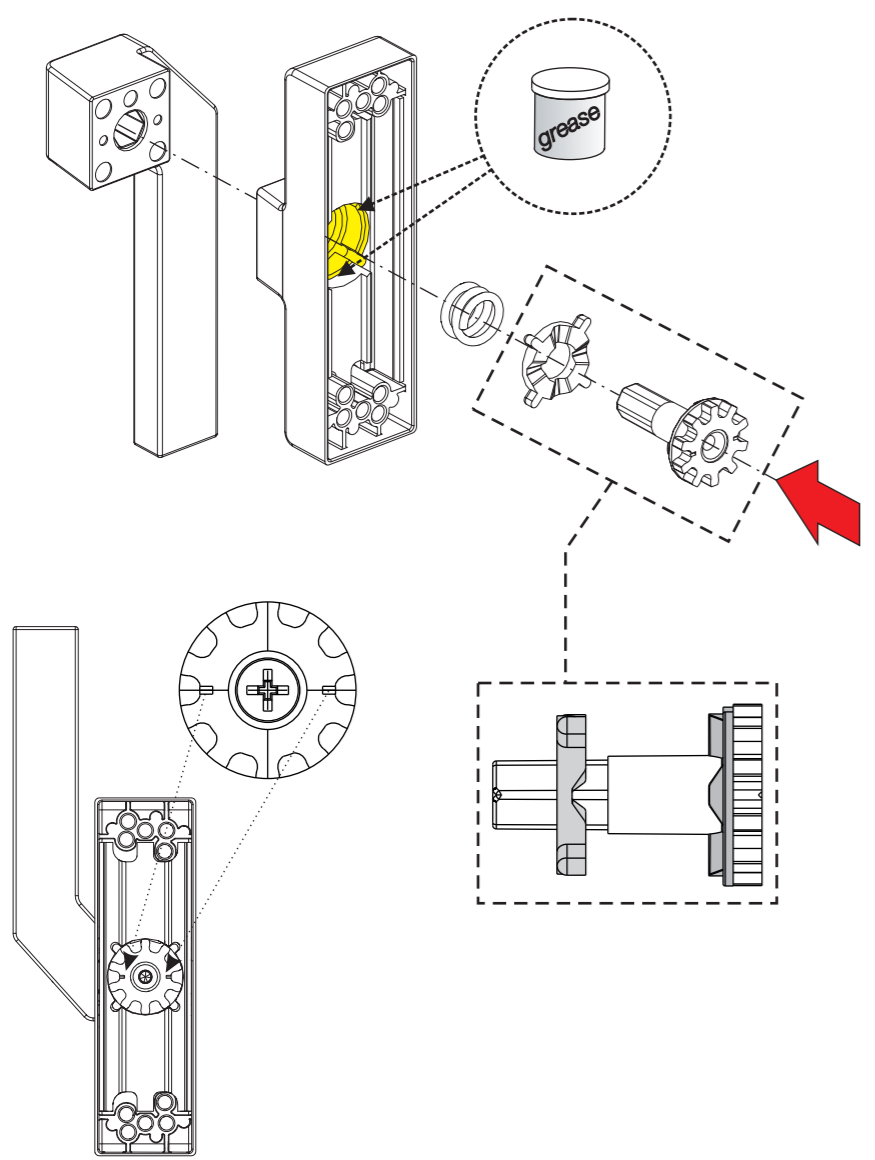

**3**

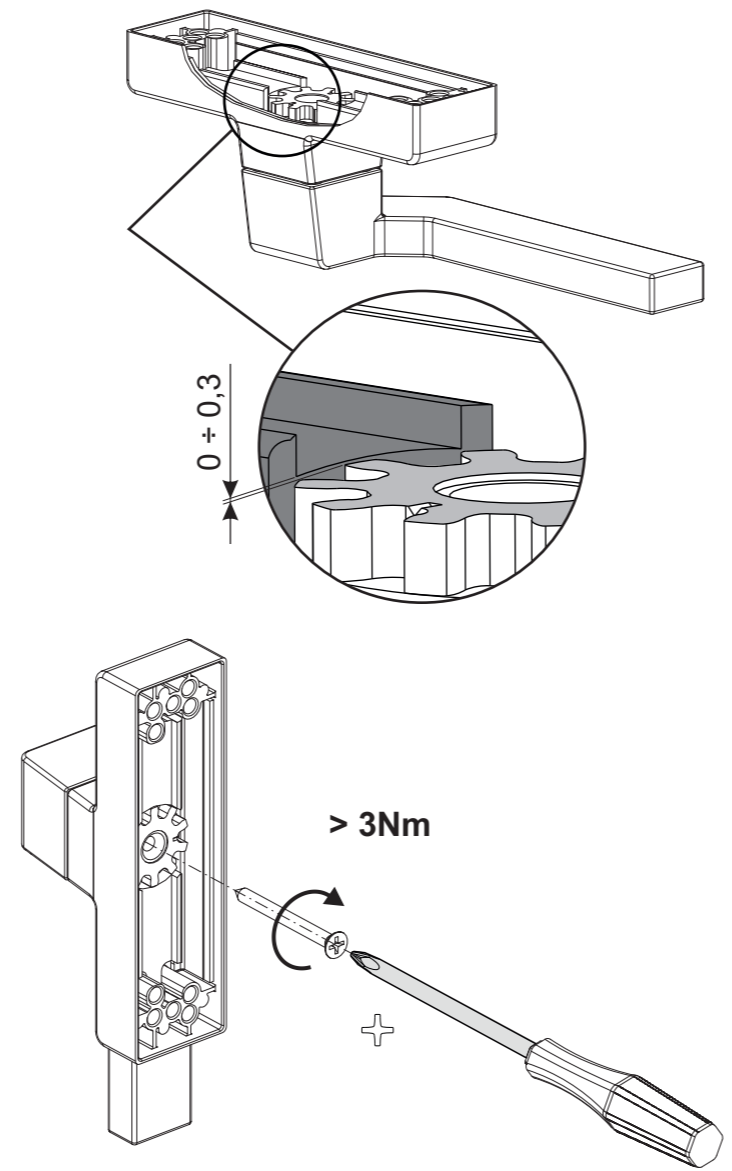

**4**

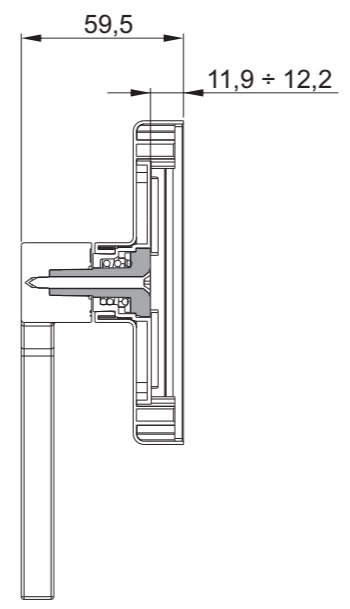

**5**

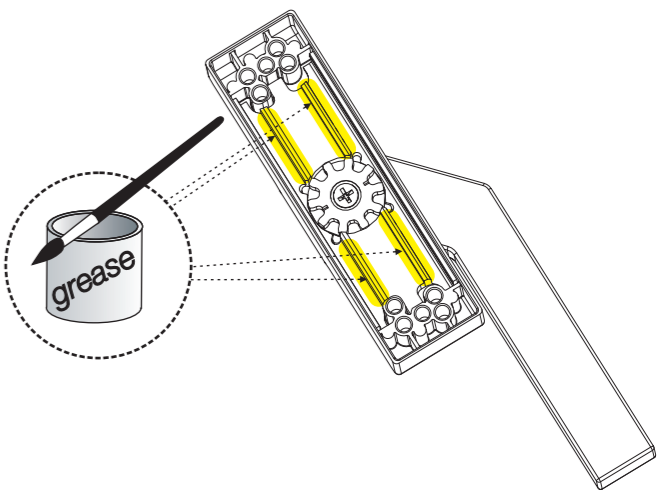

**6**

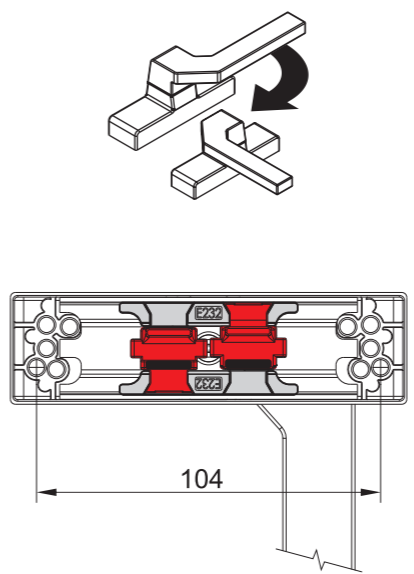

**7**

