

**SPESORE VERNICE**  
**FINISH THICKNESS**  
**PEINTURE ÉPAISSE**  
**ESPEJOR PINTURA**  
**DICKE DER LACKIERUNG**

**40 ÷ 110 µm**

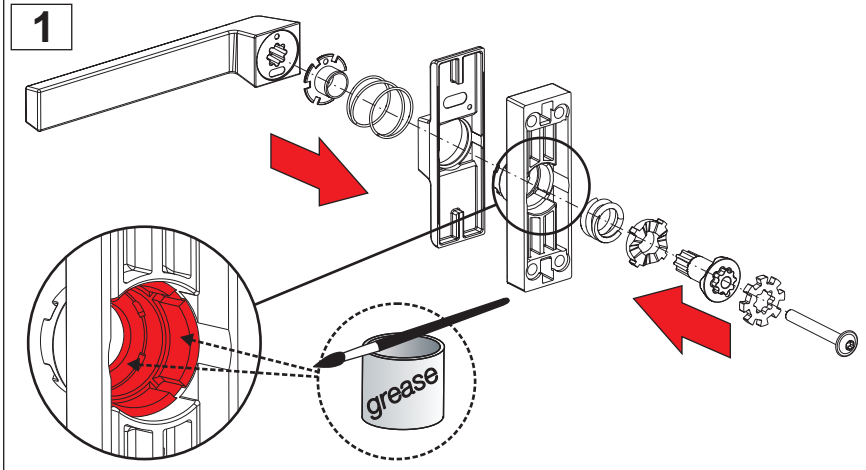
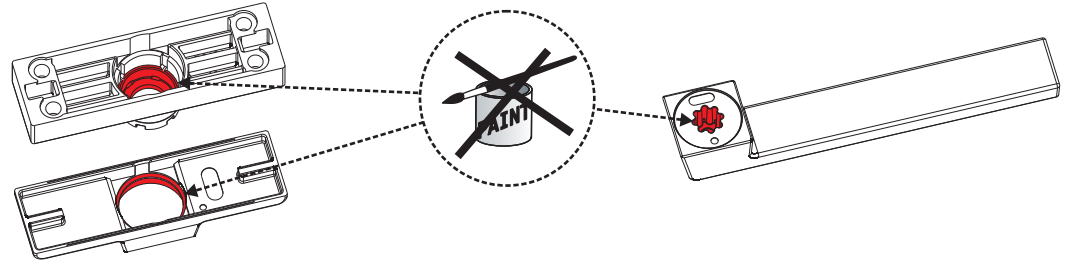

**2**

**ATTENZIONE:**  
 NECESSARIA SPECIFICA MACCHINA  
 E ATTREZZATURA DA RICHIEDERE A  
 GIESSE S.P.A.

**ATTENTION:**  
 REQUIRED SPECIFIC MACHINE  
 EQUIPMENT TO REQUEST FOR  
 GIESSE S.P.A.

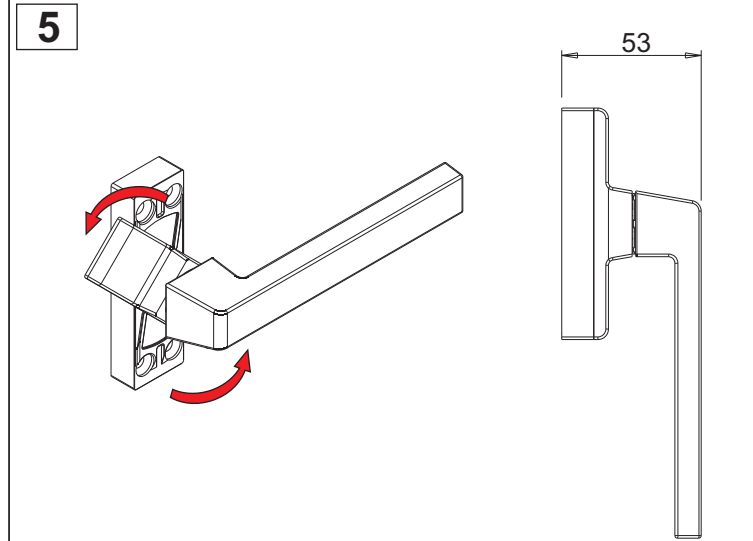
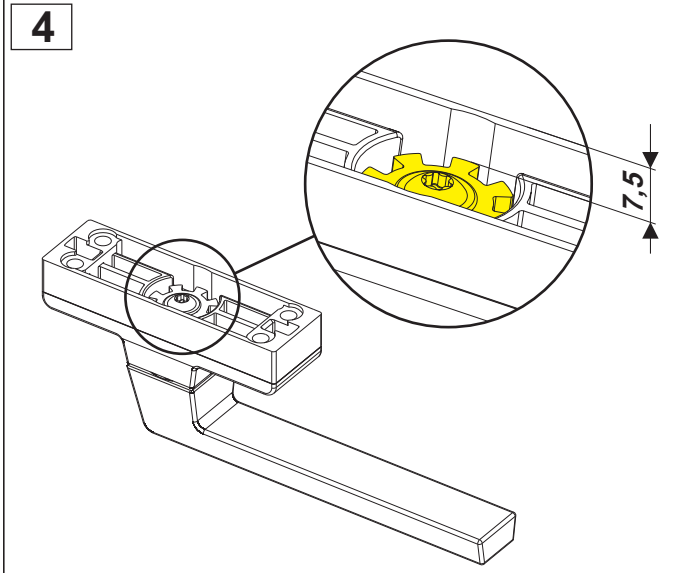
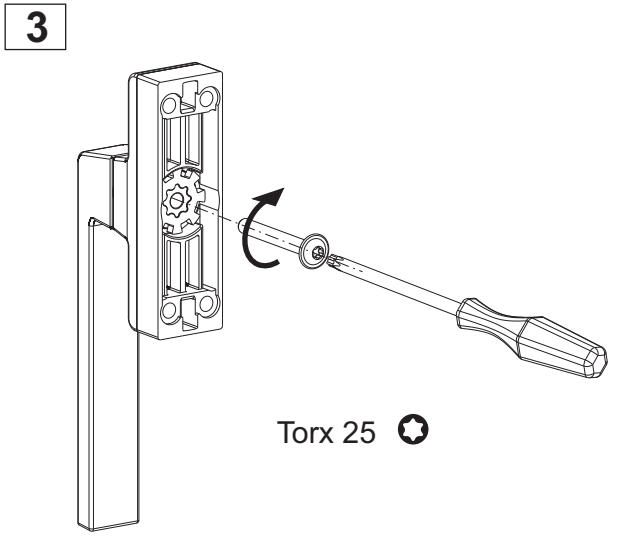
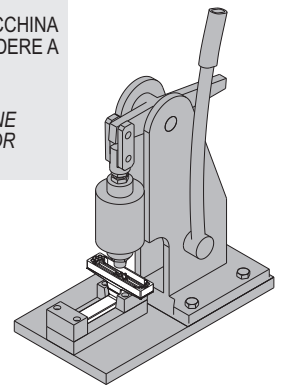

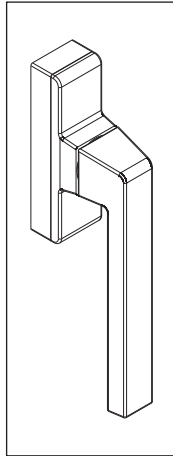

COD.	L
02025000	20 mm
02026000	28 mm
02027000	35 mm
02028000	45 mm
02029000	55 mm
02050000	65 mm

