



SASH HINGE SET FOR CHIC 3D 100

Functions

Set of hinges (top and bottom) for side-hung or secondary sash with tilt-and-turn CHIC 3D 100.

Online data sheet



Technical Features

Sash opening to 180°. Maximum load capacity 100 kg. Assembly is simple, fast and easy using the special pre-assembled cams. When there is an additional fastening mechanism, you need to use the CHIC fastening element. Both hinges are adjustable (3D). If opening is obstructed, you need to use the FRIZ limitation arm. **CAUTION:** This hinge is designed to be used only on inward opening casements and is not suitable for outward opening casements.

Materials

Corner support made of zamak
Connecting brackets and hinge plates made of zinc plated steel
Pins made of 304 grade stainless steel and aluminium bronze
Cams made of zinc plated steel

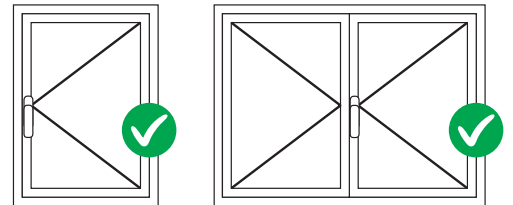

ADJUSTMENTS [mm]

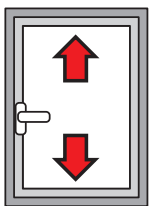

Height:
+2.5 / -1

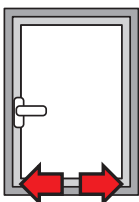

Side:
+1.5 / -1.5

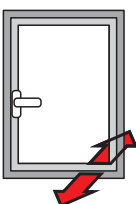

Hinge compression:
+1.4 / -0.6

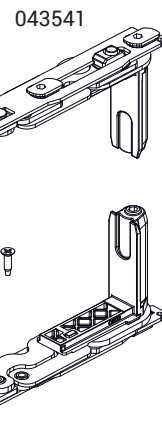
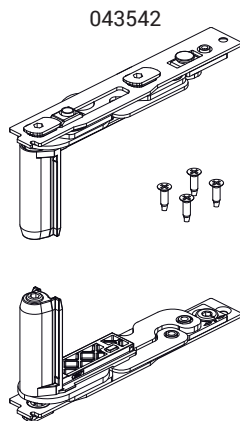

Adjustments

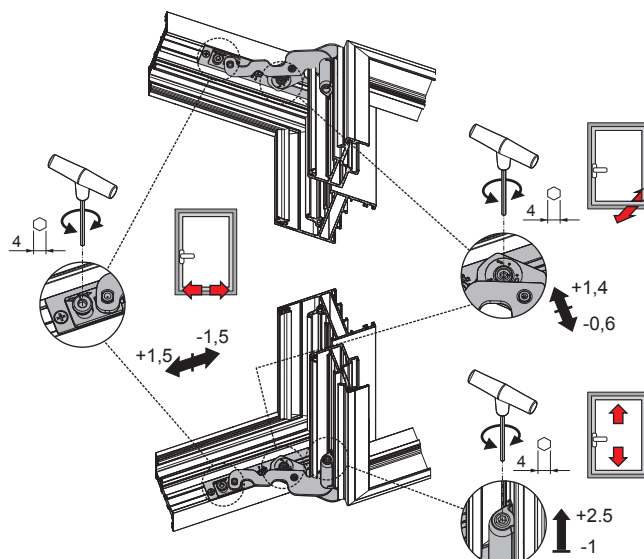

Table of maximum glass thickness [mm]

2500	33	27	23	20	18	16	15	14	13	12	11	
2400	33	27	23	20	18	16	15	14	13	12	11	
2300	34	28	24	21	19	17	16	14	13	12	11	
2200	36	30	25	22	20	18	16	15	14	13	12	
2100	37	31	27	23	21	19	17	16	14	13	12	
2000	39	33	28	25	22	20	18	16	15	14	13	
1900	41	34	30	26	23	21	19	17	16	15	14	
1800	44	36	31	27	24	22	20	18	17	16	15	
1700	46	38	33	29	26	23	21	19	18	16	15	
1600	49	41	35	31	27	25	22	20	19	17	15	
1500	50	44	37	33	29	26	24	22	20	17	15	
1400	50	47	40	35	31	28	25	23	20	17	15	
1300	50	50	43	38	34	30	27	24	20	17	15	
1200	50	50	47	41	36	33	28	24	20	17	15	
1100	50	50	50	45	40	34	28	24	20	17		
1000	50	50	50	49	42	34	28	24	20			
900	50	50	50	50	42	34	28	24				
800	50	50	50	50	42	34	28					
700	50	50	50	50	42	34						
600	160	500	600	700	800	900	1000	1100	1200	1300	1400	1500

Table of maximum load capacity [kg]

2500	100	100	100	100	100	100	100	100	100	100	100	100
2400	100	100	100	100	100	100	100	100	100	100	100	100
2300	100	100	100	100	100	100	100	100	100	100	100	100
2200	100	100	100	100	100	100	100	100	100	100	100	100
2100	100	100	100	100	100	100	100	100	100	100	100	100
2000	100	100	100	100	100	100	100	100	100	100	100	100
1900	100	100	100	100	100	100	100	100	100	100	100	100
1800	100	100	100	100	100	100	100	100	100	100	100	100
1700	100	100	100	100	100	100	100	100	100	100	100	98
1600	100	100	100	100	100	100	100	100	100	100	99	92
1500	100	100	100	100	100	100	100	100	100	100	93	87
1400	100	100	100	100	100	100	100	100	100	93	87	81
1300	100	100	100	100	100	100	100	100	94	87	80	75
1200	100	100	100	100	100	100	100	95	87	80	74	69
1100	100	100	100	100	100	100	95	87	79	73	68	
1000	100	100	100	100	96	87	79	72	67			
900	100	100	100	98	87	78	71	65				
800	100	100	99	87	77	69	63					
700	100	100	87	76	67	61						
600	160	500	600	700	800	900	1000	1100	1200	1300	1400	1500

Mandatory to use the FRIZ arm

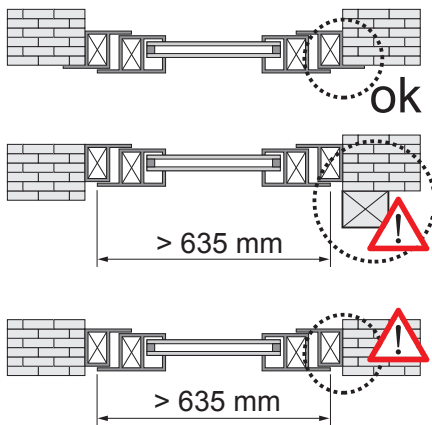

FRIZ arm positioning

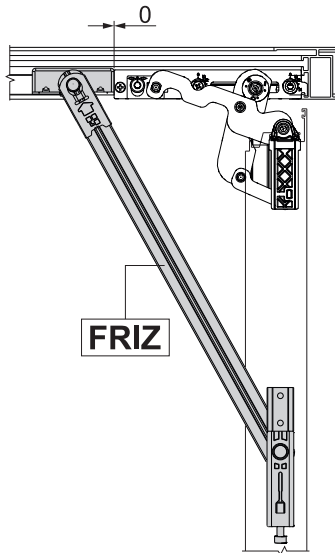

Opening angle with FRIZ arm

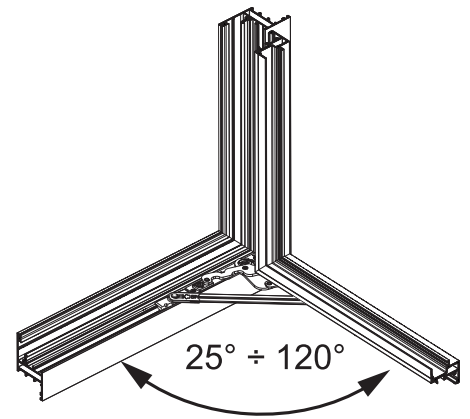

Item code	Description	PROFILE CROSS - SECTION	Hand	Load capacity 2 hinges [kg]	Load capacity 3 hinges [kg]	Base Raw	Anodised Elox	PVD	Pieces per pack
043541	CHIC - SASH HINGE SET	C001-C002-C003-C005-C006	RX	X					10
043542	CHIC - SASH HINGE SET	C001-C002-C003-C005-C006	LX	X					10