

MOBILE STRIKER

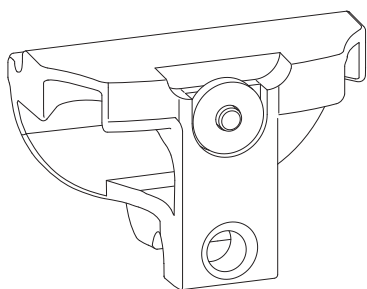

Functions

Component for positioning the mobile sash for GS1000 tilt and slide systems.

Online data sheet



Technical features

The mobile striker enables run-by of the sliding sash, for opening the secondary sash.

In configurations with an opening secondary sash, this striker replaces the fixed command striker supplied with the hardware set.

The pin with a spring keeps the striker in position and allows it to move in order to allow opening the secondary sash.

Installation can also be performed with a specific template.

Materials

Zamak striker

Spring and pin of steel

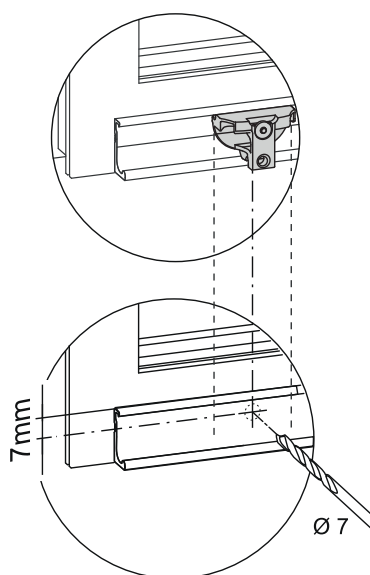

Item code	Description	Range [mm]	PROFILE CROSS - SECTION	GS1000-ML	GS1000-HL	GS1000-HD 100	GS1000-HD 160	GS1000-HD 200	Base Raw	Anodised Elox	Painted	Trend/Gold Brass	Pieces per pack
0979001	MOBILE STRIKER	-	-	X	X	X	X	X	X				1