

MOBILE STRIKER

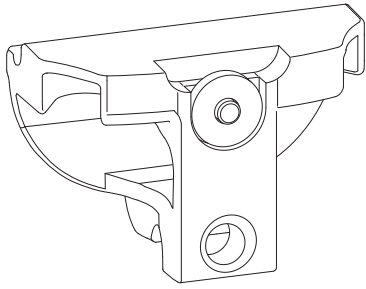

Functions

Component for positioning the mobile sash for GS1000 tilt and slide systems.

Online data sheet



Technical features

The mobile striker enables run-by of the sliding sash, for opening the secondary sash.

In configurations with an opening secondary sash, this striker replaces the fixed command striker supplied with the hardware set.

The pin with a spring keeps the striker in position and allows it to move in order to allow opening the secondary sash.

Materials

Zamak striker
Spring and pin of steel

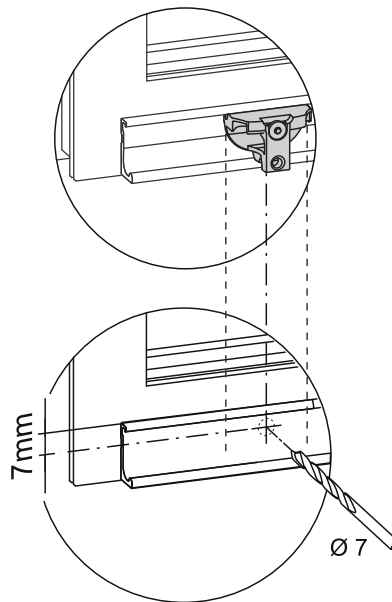

Item code	Description	Range [mm]	PROFILE CROSS - SECTION	GS1000-ML	GS1000-HL	GS1000-HD 100	GS1000-HD 160	GS1000-HD 200	Base Raw	Anodised Elox	Painted	Trend/Gold Brass	Pieces per pack
0979001	MOBILE STRIKER	-	-	X	X	X	X	X	X				1