

MASTER PLUS HANDLE



Functions

Pair of aluminium handles, reversible with stop, for fitting on the upright or centre rail of the door.

Online data sheet



Technical Features

The MASTER PLUS door handle comprises a base and a rotor which, combined with a return spring, allows reversible operation and horizontal positioning of the handle.

Instant access to the fixing screws by simply rotating the plate cover.

The double C/C distance of the drilling, 43 and 50 mm, enables the handle to be fitted on the majority of profiles available on the market.

Fixing to the profile is carried out using the $\varnothing 4.2 \times 16$ self-threading screws supplied with the handle.

The base has 4 holes, with c/c distance 38 mm, for using additional screws (not provided) when changing the handle.

The handle rotor is equipped with a mechanical stop that safeguards the end stroke of the spring, preventing damage and consequent breakage, in case of incorrect operation.

The 110 mm square pin supplied lets you install the handle on profiles from 78 to 82 mm wide (without cutting the pin).

The handle is protected and finished using the GIESSE painting system, which guarantees high quality surfaces, uniformity of colour and excellent resistance to abrasions.

The components are pretreated to guarantee resistance to surface scaling.

Materials

Handle in die-cast aluminium

Rotor in zinc plated zamak

Self-forming screw for fixing to the rotor made of zinc-plated steel

Base and cover made of painted zamak

Compression spring made of stainless steel

Steel return spring

Screws for fixing to the profile and square pin

8x8x110 in zinc plated steel

Shim washers made of acetal resin

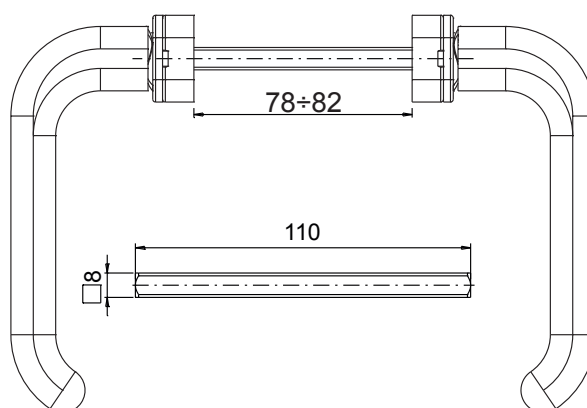

DOOR HANDLES

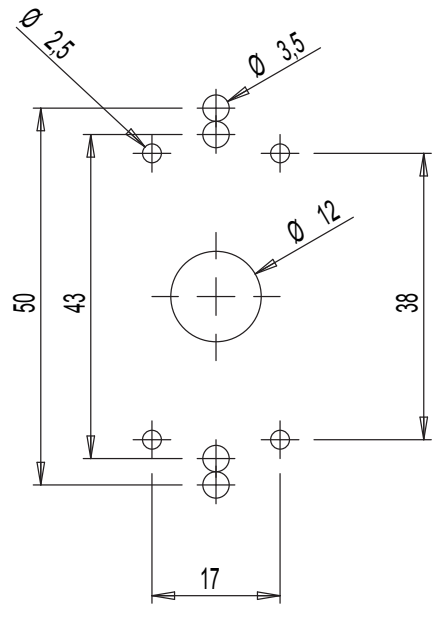
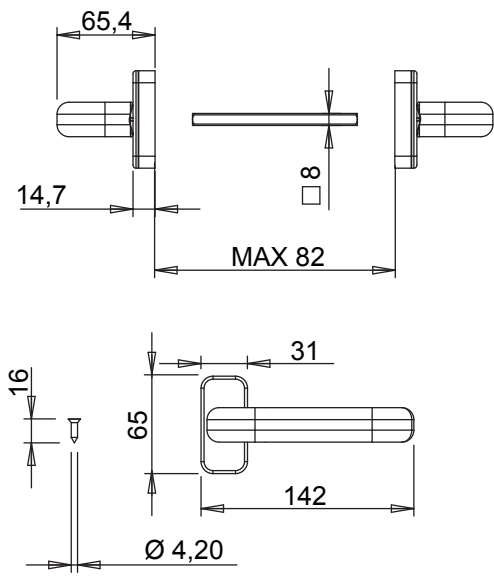

Item code	Description	Note	Square spindle [mm]	Base Raw	Anodised Elox	Painted	Trend/Gold Brass	Pieces per pack
02422	MASTER PLUS HANDLE	pair	8x8x110	X		X		10