

## ASIA WINDOW HANDLE GS3000-150

### Functions

Window handles for GS3000-150 lift and slide system.

Online data sheet



### Technical features

Long window handle for lift and slide window with ASIA style to construct sashes up to 150 kg.  
 7/10 mm square pin.  
 43 mm fixing C/C distance.  
 Available in single version without key.  
 Compatible with driving rods with 25 mm backset.  
 Can be combined with recess handle with 43 mm C/C distance.

### Materials

Aluminium handle and cover  
 Zamak case  
 Rotor made of zinc-plated steel  
 Trim ring made of acetal resin  
 Square pin in zinc plated steel  
 Fixing screws, zinc-coated steel

ASIA window handle L240 -I43



ASIA window handle dimensions L240 -I43

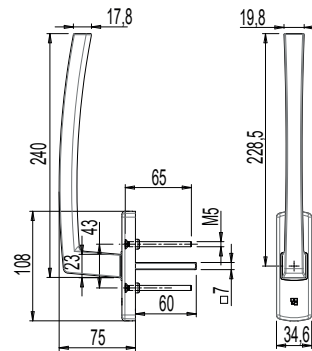

Recess handle



Recess handle dimensions

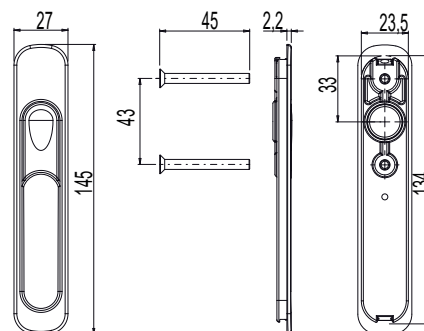

Item code	Description	C/C distance (l)	Handle length (L)	Compatible with drive gear	Base Raw	Anodised Elox	Painted	Trend/Gold Brass	Pieces per pack
0243201	ASIA WINDOW HANDLE L240-I43 GS3000	43 mm	240 mm	E =25 mm	X	X	X	X	1
02764	EXTERNAL RECESS PULL HANDLE	43 mm	-	E = 25mm	X		X	X	8