

**AP200 MECHANISM**



**Functions**

TOUCH BAR type safety panic exit device for slip-on mounting.

Online data sheet



**Technical Features**

The AP200 mechanism consists of:

- the reversible mechanism (A) and its mechanism protection plug (B)
- the pre-assembled round coupling shim (C)
- the base with push-bar and mechanism (D), with assembled front and rear caps
- square connecting pin between the fastening mechanism and lock (E)
- the shimming plate (F)

The device to insert should be combined with the following components:

- the security locks with one-point and three-point fastening, to be chosen depending on the profile and the type of application with specific counterplates
- specific strikers for the lock used cylinder

**Materials**

- Mechanisms in zinc plated steel
- Painted steel mechanism protection plug
- Brackets in Zamak
- Shimming plates in zinc plated steel
- Grub screws and fixing screws in zinc plated steel

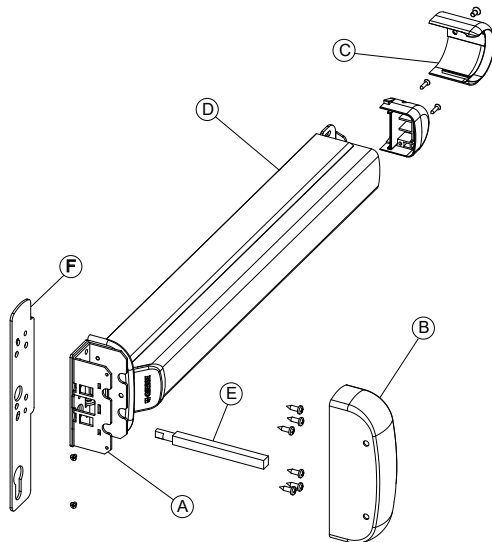

Item code	Description	Note	Base Raw	Anodised Elox	Painted	Trend/Gold Brass	Pieces per pack
07430	PANIC EXIT DEVICE AP200	L=1170			X		1
07431	PANIC EXIT DEVICE AP200	L=1300			X		1