



## ROLLER AND BOLT LOCKS

### Functions

Central lock, slip-on version for aluminium uprights , with roller and pivoting bolt.

Online data sheet



### Technical Features

Lock compatible with European profile cylinders, has a burglar-proof pivoting bolt and a protrusion adjustable roller.

Bolts operated with the cylinder.

Bolt with thickness of 10 mm and minimum protrusion of 24 mm.

Roller protrusion adjustable from 7 mm to 16,5 mm.

### Materials

Lock cover plate and case plate in zinc plated steel

Flat front in stainless steel

Nickel-plated zamak roller

Nickel-plated steel bolt

Polyamide cylinder machining cover studs

Zinc plated steel cylinder fixing screw

Lock fixing screws in stainless steel

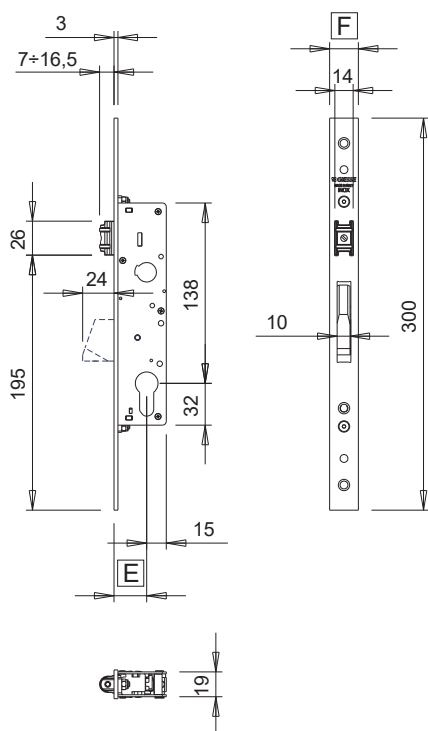

Item code	Description	Backset E [mm]	Front width F [mm]	Compatible counterplates	Base Raw	Anodised Elox	Painted	Trend/Gold Brass	Pieces per pack
04616	CENTRAL LOCK WITH ROLLER	25	22	04630 - 04639 - 04859 - 04860	X				10
04617	CENTRAL LOCK WITH ROLLER	30	22	04630 - 04639 - 04859 - 04860	X				10
04618	CENTRAL LOCK WITH ROLLER	35	22	04630 - 04639 - 04859 - 04860	X				10
04622	CENTRAL LOCK WITH ROLLER	25	24	04630 - 04639 - 04859 - 04860	X				10
04623	CENTRAL LOCK WITH ROLLER	30	24	04630 - 04639 - 04859 - 04860	X				10
04624	CENTRAL LOCK WITH ROLLER	35	24	04630 - 04639 - 04859 - 04860	X				10