

SKATTO COMPENSATOR TOOL

Functions

Tool used to do the machining for mounting the SKATTO compensator.

Online data sheet



Technical features

It consists of an adjustable counterbore and an adjustable stop.
Counterbore tool with 2 diameters, one for fixing the compensator $\varnothing 16.2$ and one for the screw passage $\varnothing 7$.

Materials

Tool body made of special steel
Adjustable counterbore made of special steel
Adjustable stop made of treated steel
2 Flat-tipped stainless steel grub screws M 5 x 5.

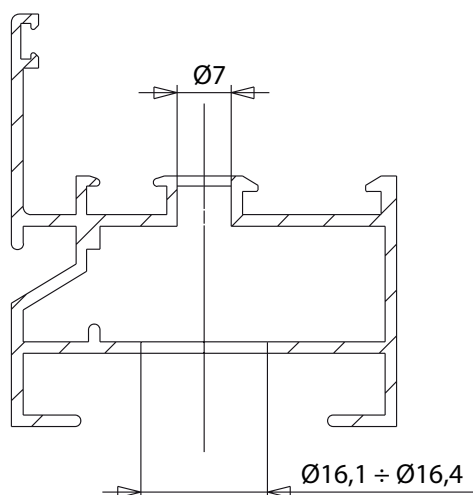

| Item code | Description | Note | Base Raw | Anodised Elox | Painted | Trend/Gold Brass | Pieces per pack |
|-----------|-------------------------|------|----------|---------------|---------|------------------|-----------------|
| 06510 | SKATTO COMPENSATOR TOOL | | X | | | | 1 |