

DIRECT FIXING SCREWS



Functions

M12 screw for direct fixing of DOMINA HP, DOMINA HP COVER and DOMINA CLASSIC hinges to thermal break profiles.

Online data sheet



Technical Features

Using the M12 direct fixing screw, DOMINA HP, DOMINA HP COVER and DOMINA CLASSIC hinges can be fitted to thermal break type profiles without using counterplates located internally of the hollow section (*).

Available in four different lengths:

W = 55 mm

W = 65 mm

W = 75 mm

W = 90 mm

When fitting hinges with the direct fixing screw, the profile must be prepared by drilling a $\varnothing 11$ mm hole with the aid of machining templates item 03237, item 05052 and item 05050 (specifically for corner hinges).

(*) Except for Domina HP and Domina HP Cover hinge, c/c distance 55.5

Materials

Zinc-coated steel fixing screw

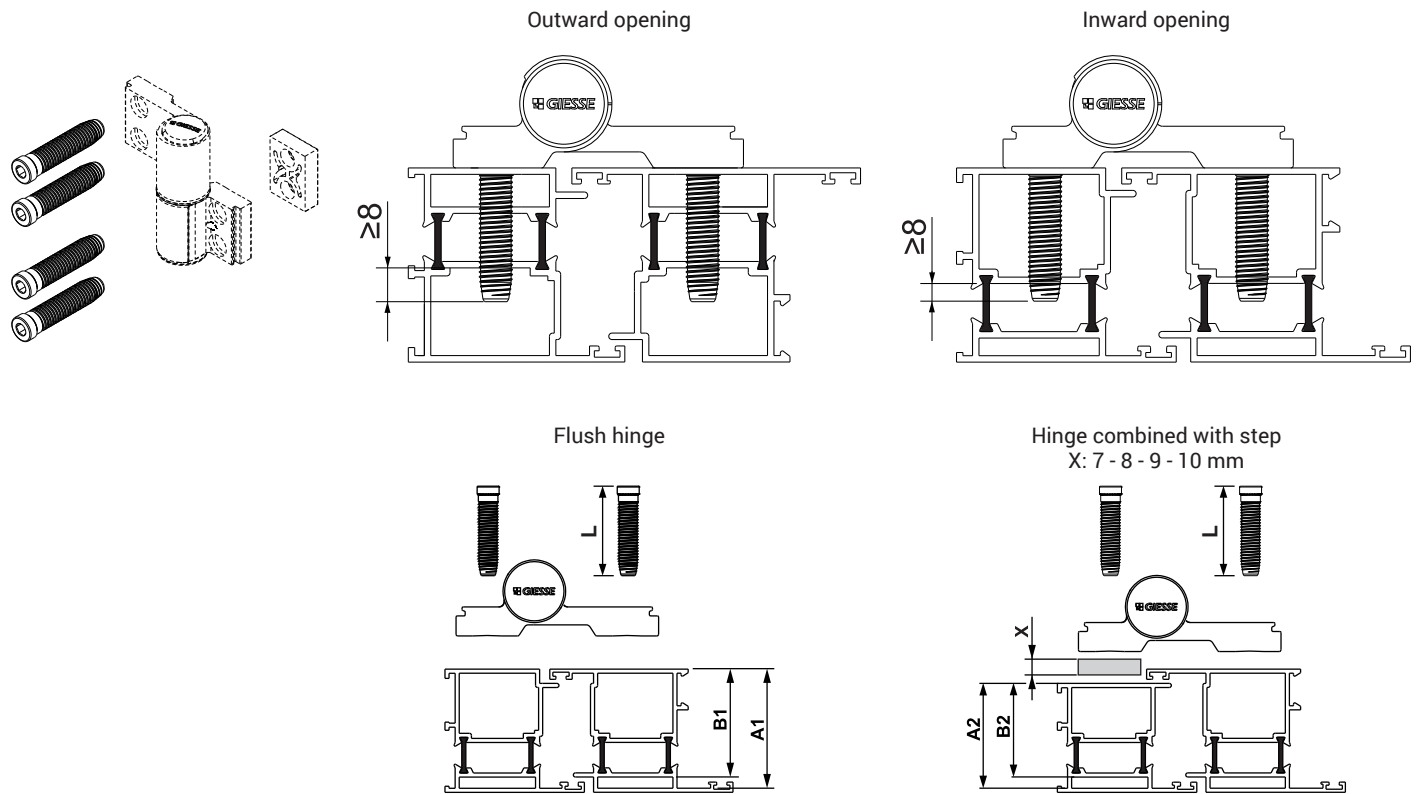

Item code	Description	L [mm]	A1 [mm]	B1 [mm]	A2 [mm]	B2 [mm]	Base Raw	Anodised Elox	Painted	Trend/Gold Brass	Pieces per pack
05300	DIRECT FIXING SCREW M12x55	55	≥ 42	≤ 34	$\geq 42-X$	$\leq 34-X$	X				20
05301	DIRECT FIXING SCREW M12x65	65	≥ 52	≤ 44	$\geq 52-X$	$\leq 44-X$	X				20
05302	DIRECT FIXING SCREW M12x75	75	≥ 62	≤ 54	$\geq 62-X$	$\leq 54-X$	X				20
05303	DIRECT FIXING SCREW M12x90	90	≥ 77	≤ 69	$\geq 77-X$	$\leq 69-X$	X				20