

CARROS FIJOS 1 RUEDA



Funciones

Carro de aluminio extruído de una rueda para ventanas o puertas correderas de aluminio.

Ficha técnica on-line



Características Técnicas

La rueda está montada sobre un cojinete de bolas.
Se caracteriza por poder ser inspeccionado sin tener que desmontar la hoja al quitar los tornillos de fijación.

03529

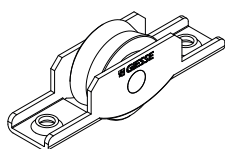

03539

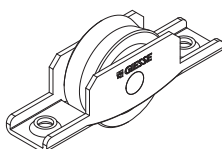

03558

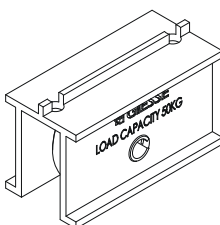

03121

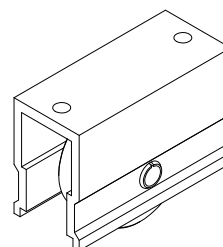

03151N

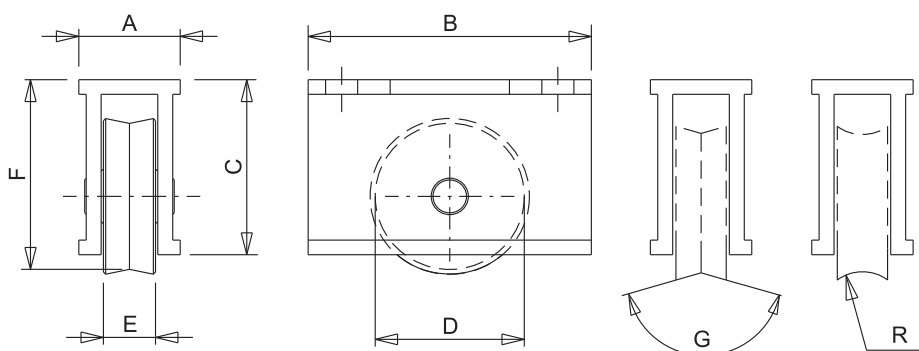
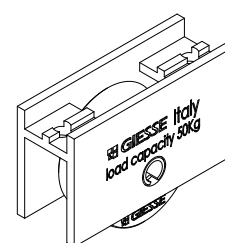

Código	Descripción	Nota	Capacidad (kg)	A [mm]	B [mm]	C [mm]	D [mm]	E [mm]	F [mm]	G [°]	Cojinete	Soporte externo	Base Bruto Anodizado Elox	Lacado	Trend/Otro Latón	Unidades por confección
03529	CARRO FIJO 1 RUEDA	Confección a granel	50	16	70	15,6	24	11	/	156°	Bolas	Acero	X			200
03539	CARRO FIJO 1 RUEDA	Confección a granel	50	16	70	18	28	11	-	156°	Bolas	Acero	X			200
03558	CARRO FIJO 1 RUEDA	Confección a granel	60	24	50	30,4	28	12	34,85	156°	Bolas	Aluminio	X			200
03121	CARRO FIJO 1 RUEDA	Juego de 4 un.	60	21,5	50	33	28	12	38,5	156°	Bolas	Aluminio	X			50
03151N	CARRO FIJO 1 RUEDA	Juego de 4 un.	50	17,8	50	29,2	28	12	35,25	156°	Bolas	Aluminio	X			100