

SYSTÈME UNICA CRÉMONE



Fonctions

Crémone sans composants internes.
 Peut se transformer en crémone pour ouverture interne, ouverture extérieure, oscillo-battant en fonction des cas, au moyen des kits spéciaux (livrés avec les points de fermeture).

Fiche technique en ligne



Caractéristiques techniques

La manœuvre de crémone UNICA est disponible en plusieurs versions et est livrée sans composants internes. Le montage de ces pièces, faisant partie du kit, est réservé au menuisier, bien qu'il soit simple et rapide.
 Toutes les crémones Unica présentent un entraxe de fixation de 104 mm.

Matériaux

Poignée en aluminium moulé sous pression
 Caisses et engrenage en zamak pressofusé
 Ressort en acier
 Vis en acier zingué
 Rondelle en Hostaform

Exemple de montage de la crémone pour oscillo-battant (01150N+04071N)

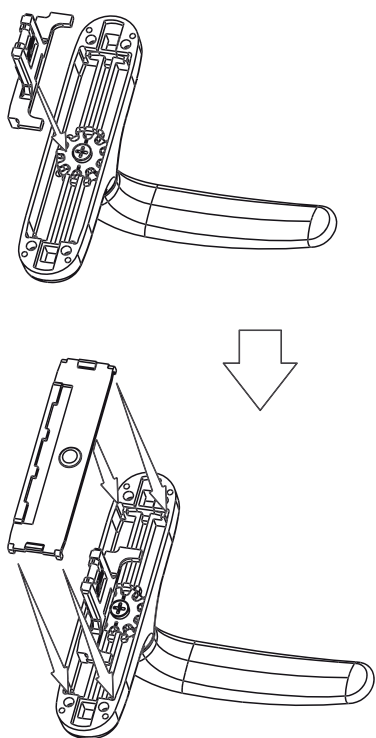

Exemple de montage de la crémone Apex (01150N+02259)

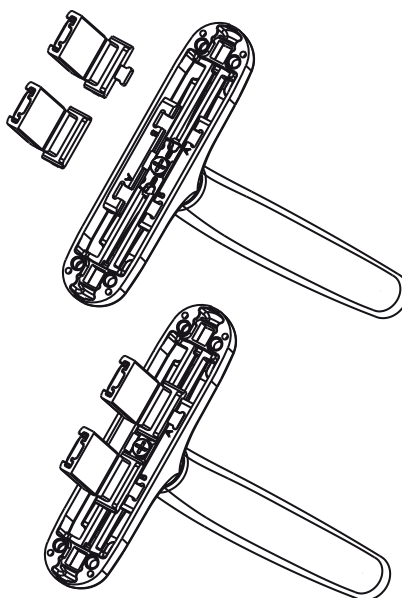

Usinage entraxe 104 mm

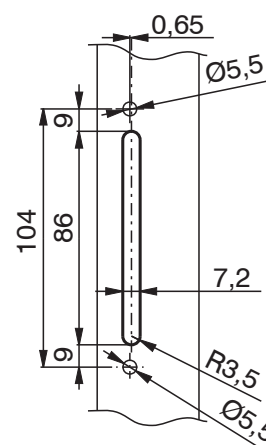

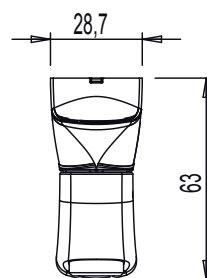
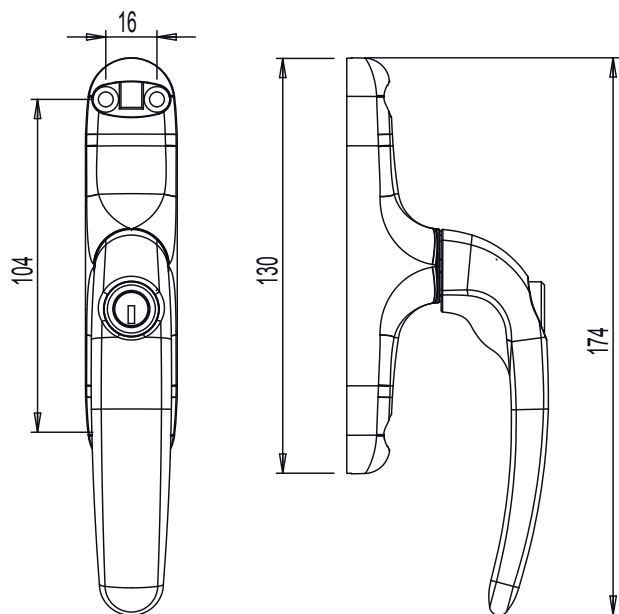
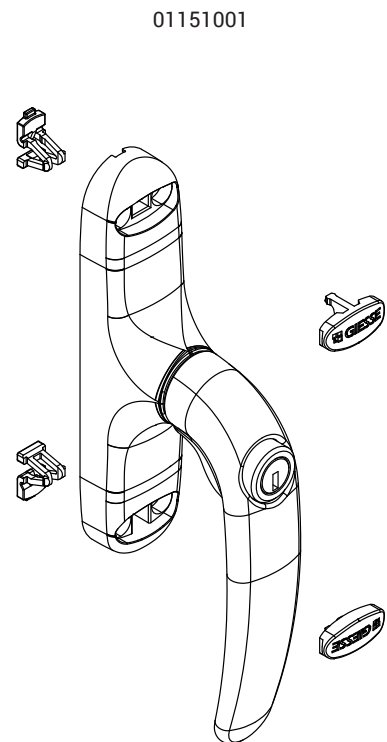
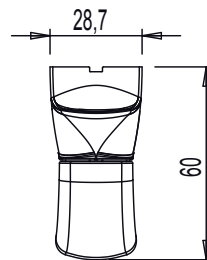
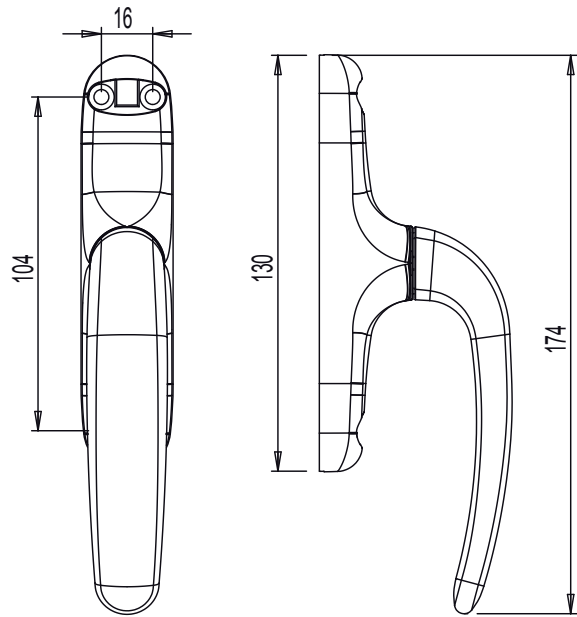
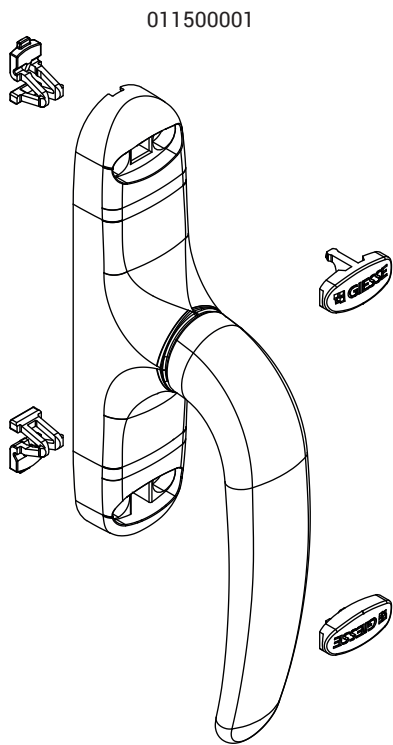

01230

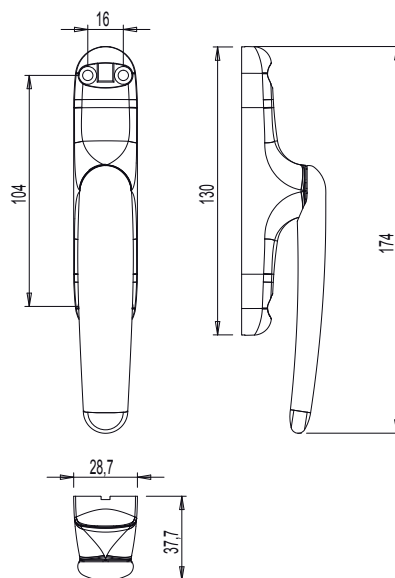
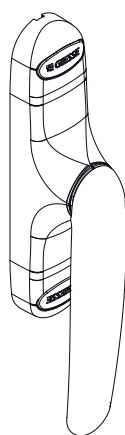

01125

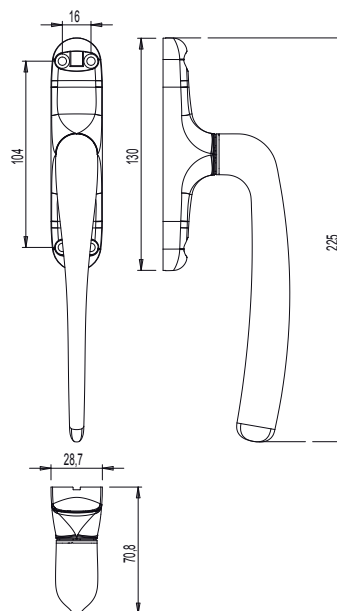
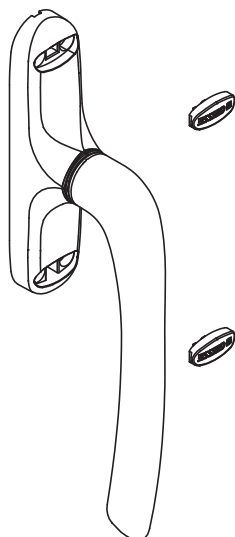

01126

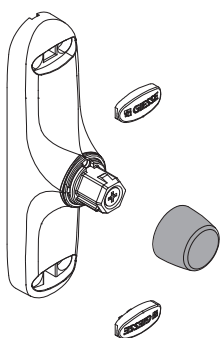

01129

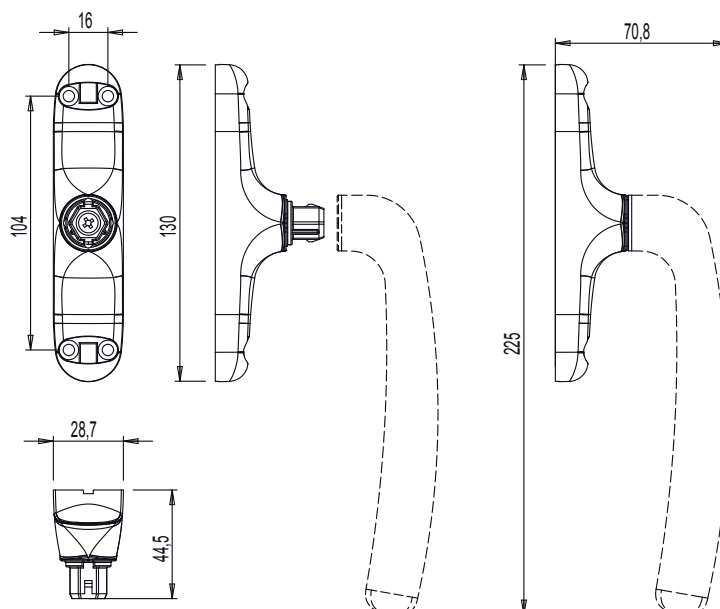
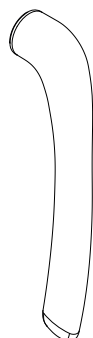

011691

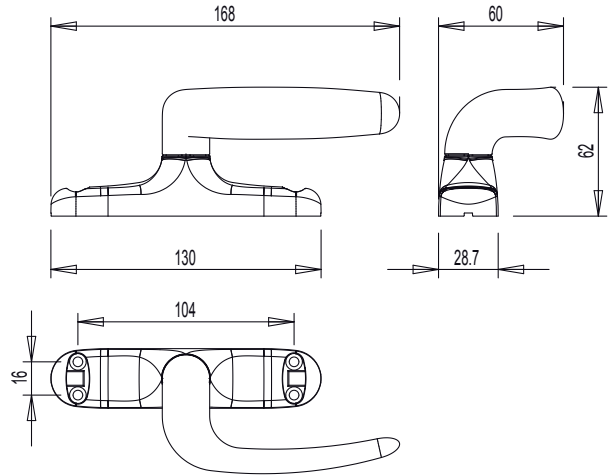
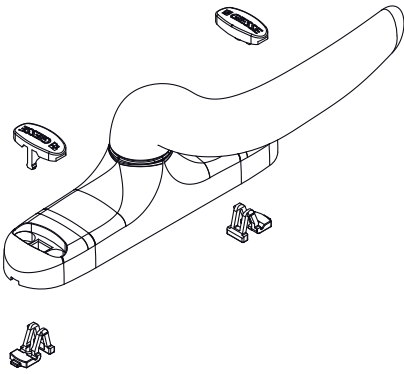

011692

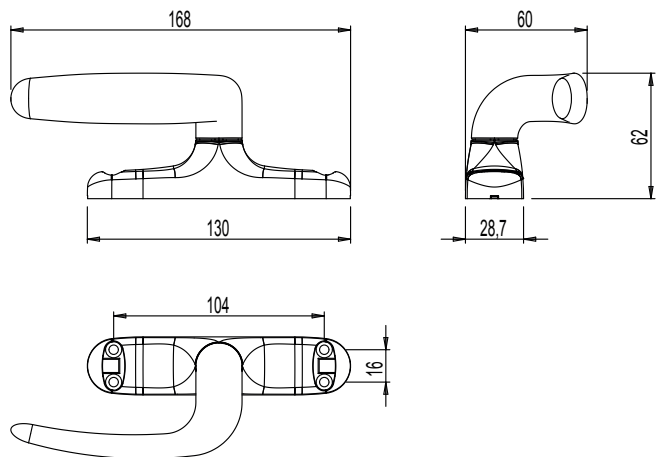
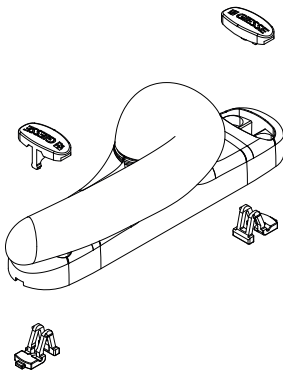

01063

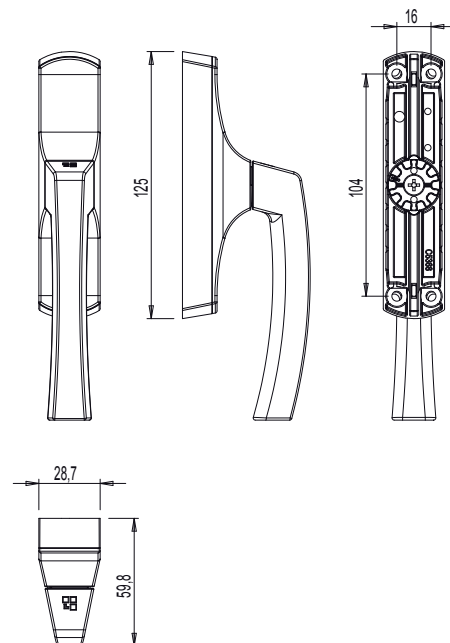
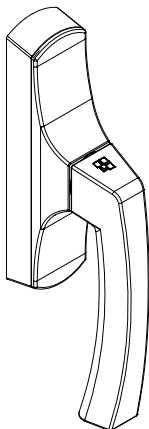

Référence article	Description	GORGE	Main	Entraxes	Brut	Anodisé Elox	Laqué	Trend/Or Laiton	Pièces par boîte
01063	CRÉMONE ASIA OUTWARD 0-180°	C001-C007-P002		104 mm	X		X		10
01125001	CRÉMONE SYST.UNICA POIGNÉE L=172	C001-C002-C003-C004-C005-C006-C007-C008-C009-C010-C012-C013-C014-C015-C016-C017-P001-P002-P004-P005-P006-P007-P008-P009-P010		104 mm			X		10
01126	CRÉMONE UNICA AWAY	C001-C002-C003-C004-C005-C006-C007-C008-C009-C010-C012-C013-C014-C015-C016-C017-P001-P002-P004-P005-P006-P007-P008-P009-P010		104 mm			X		10
01129	POIGNÉE POUR UNICA - AWAY	C001-C002-C003-C004-C005-C006-C007-C008-C009-C010-C012-C013-C014-C015-C016-C017-P001-P002-P004-P005-P006-P007-P008-P009-P010		-			X		10
01150001	CRÉMONE SYSTÈME UNICA	C001-C002-C003-C004-C005-C006-C007-C008-C009-C010-C012-C013-C014-C015-C016-C017-P001-P002-P004-P005-P006-P007-P008-P009-P010		104 mm	X		X	X	10
01151001	CRÉMONE UNICA KEY	C001-C002-C003-C004-C005-C006-C007-C008-C009-C010-C012-C013-C014-C015-C016-C017-P001-P002-P004-P005-P006-P007-P008-P009-P010		104 mm	X		X	X	10
011691	CRÉMONE UNICA POIGNÉE DESAXÉE CW2	-	Droite	104 mm	X		X		5
011692	CRÉMONE UNICA POIGNÉE DESAXÉE CW2	-	Gauche	104 mm	X		X		5
01230	CRÉMONE UNICA RABAISSÉ	C001-C002-C003-C004-C005-C006-C007-C008-C009-C010-C012-C013-C014-C015-C016-C017-P001-P002-P004-P005-P006-P007-P008-P009-P010		104 mm	X		X	X	5