

SISTEMA UNICA CREMONESE



Funzioni

Cremonese priva dei componenti interni.
A seconda delle necessità può essere trasformata in Cremonese per apertura Interna, apertura Esterna, Anta Ribalta, utilizzando gli specifici kit (forniti anche completi dei punti di chiusura).

Scheda tecnica on-line



Caratteristiche Tecniche

La manovra cremonese UNICA è disponibile in differenti versioni ed è fornita priva dei particolari interni. L'operazione di montaggio degli stessi, contenuti all'interno dei kit di personalizzazione, è demandata al serramentista, ma di semplice e rapida esecuzione.

Tutte le cremonesi Unica hanno interasse di fissaggio 104 mm.

Materiali

- Manico in alluminio pressofuso
- Casse e ingranaggio in zama pressofusa
- Molla in acciaio
- Vite in acciaio zincato
- Rasamento in Hostaform

Esempio montaggio cremonese anta ribalta (01150N+04071N)

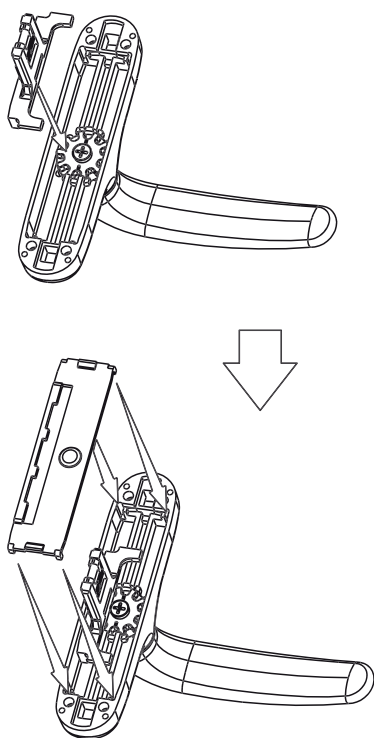

Esempio montaggio cremonese Apex (01150N+02259)

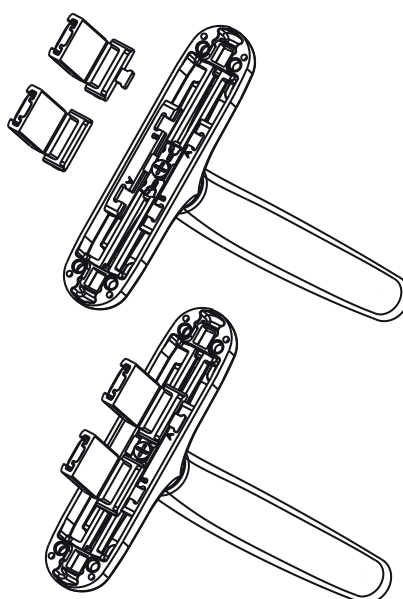

Lavorazione interasse 104 mm

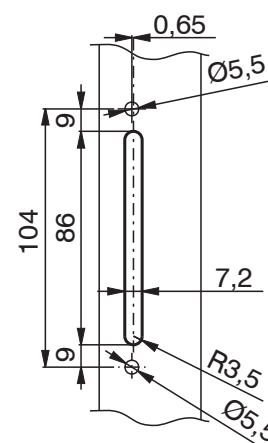

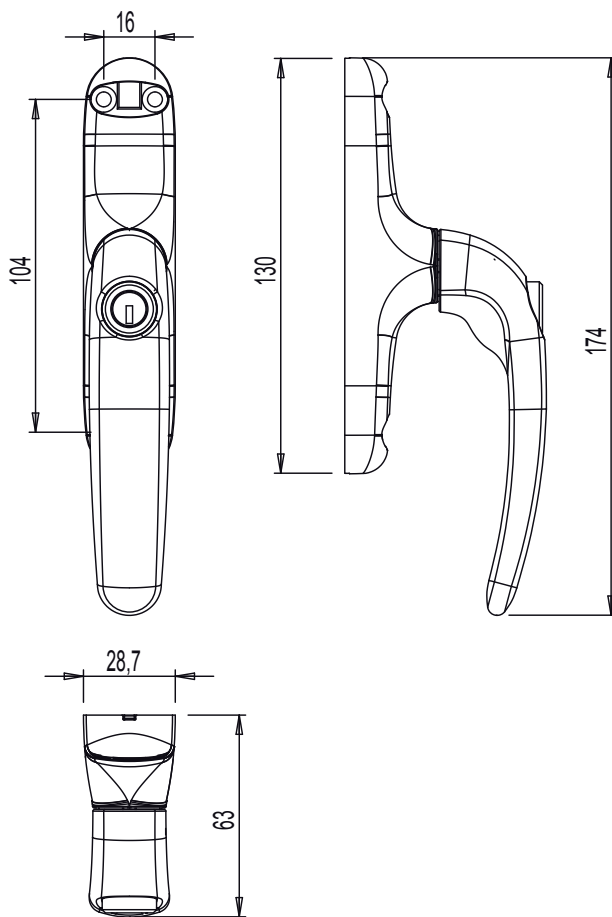
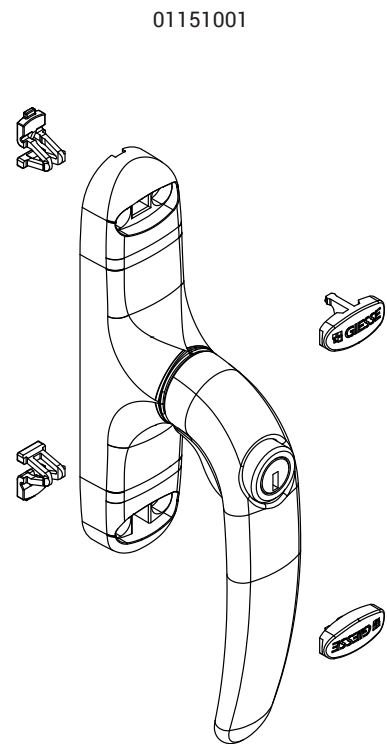
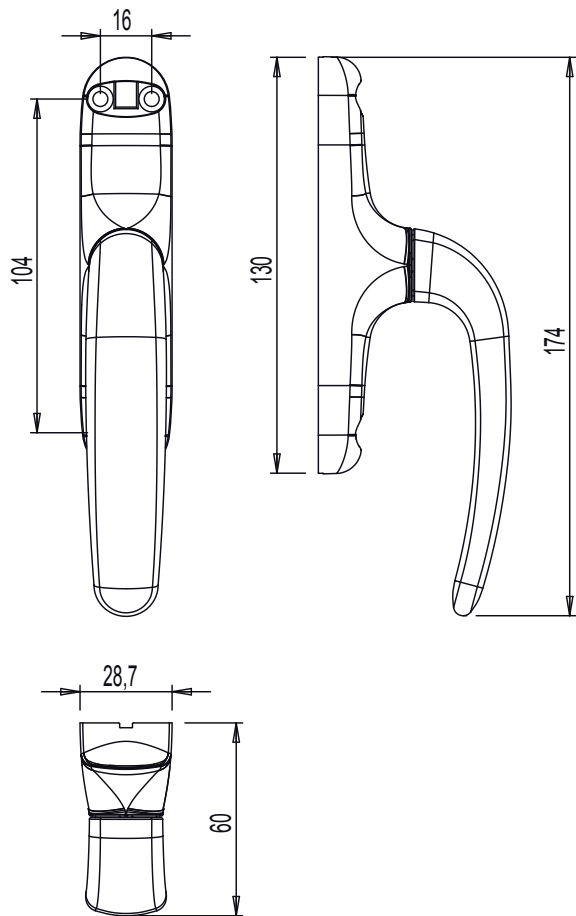
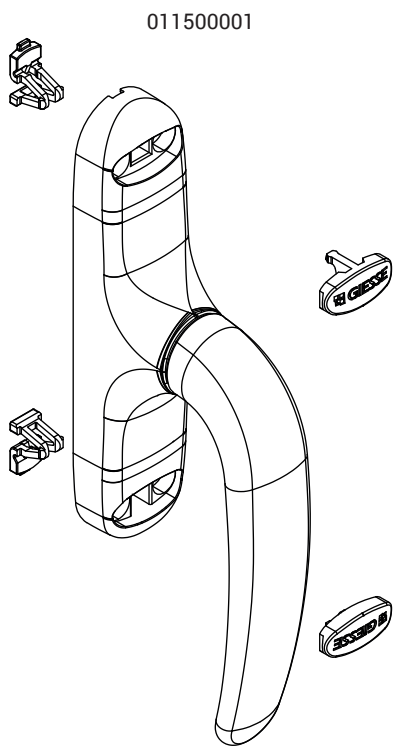

01230

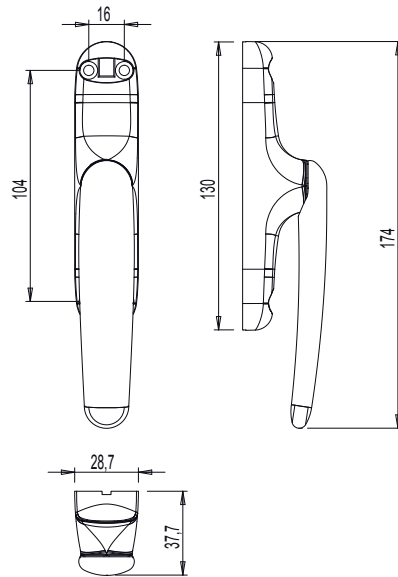

01125

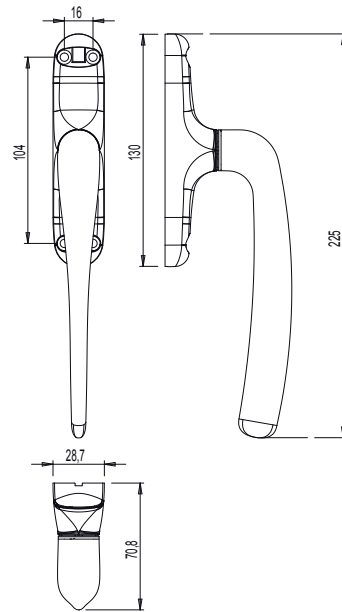
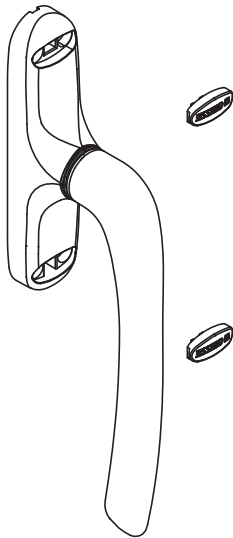

01126

01129

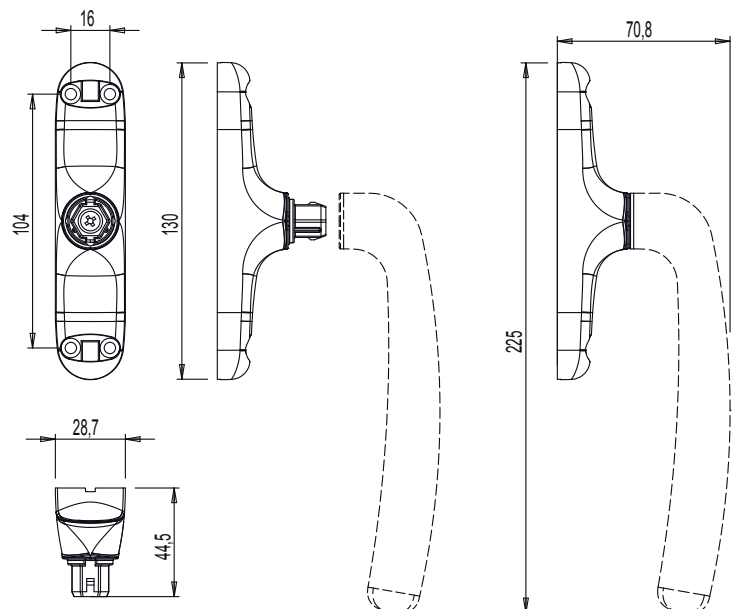
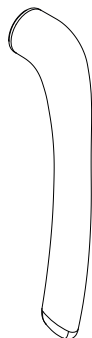
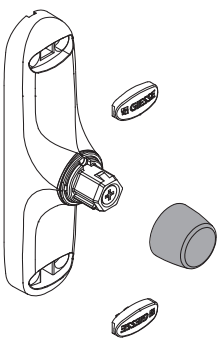

011691

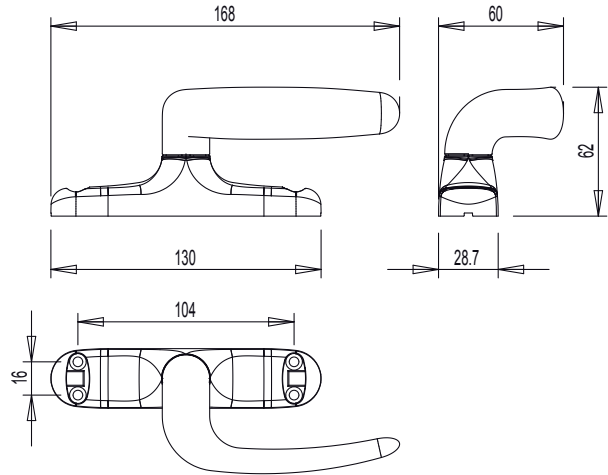
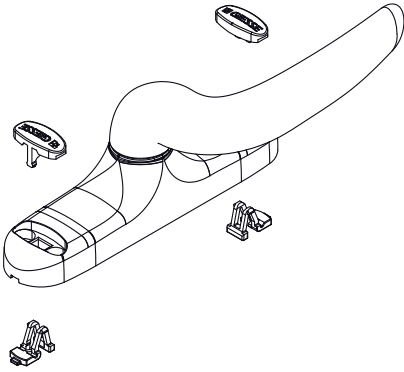

011692

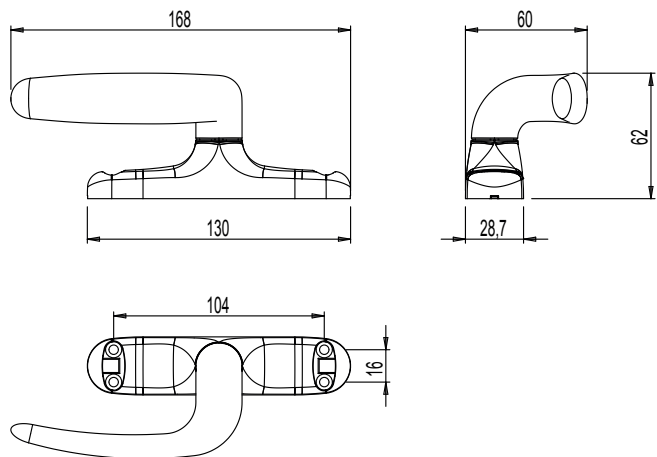
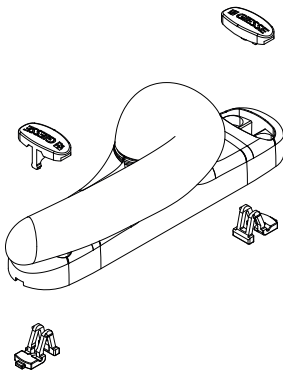

01063

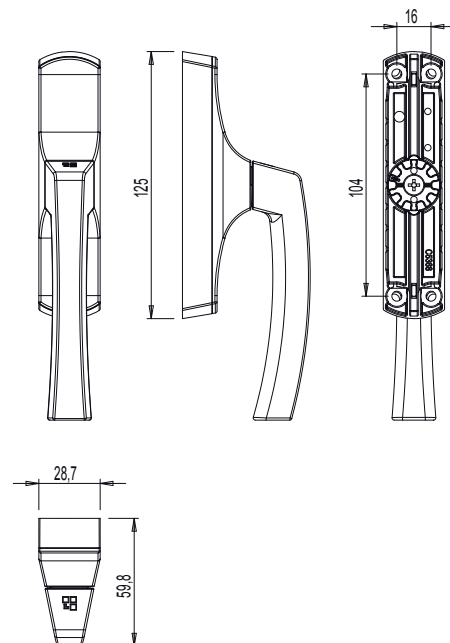
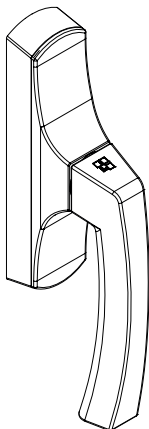

Codice	Descrizione	NODO	Mano	Interassi	Base Grezzo	Anodizzato Elox	Verniciato	Trend/Oro Ottone	Pezzi per confezione
01063	CREMONESE ASIA OUTWARD 0-180°	C001-C007-P002		104 mm	X		X		10
01125001	CREMONESE SIST.UNICA MANICO L=172	C001-C002-C003-C004-C005-C006-C007-C008-C009-C010-C012-C013-C014-C015-C016-C017-P001-P002-P004-P005-P006-P007-P008-P009-P010		104 mm			X		10
01126	CREMONESE UNICA AWAY	C001-C002-C003-C004-C005-C006-C007-C008-C009-C010-C012-C013-C014-C015-C016-C017-P001-P002-P004-P005-P006-P007-P008-P009-P010		104 mm			X		10
01129	MANICO PER UNICA - AWAY	C001-C002-C003-C004-C005-C006-C007-C008-C009-C010-C012-C013-C014-C015-C016-C017-P001-P002-P004-P005-P006-P007-P008-P009-P010		-			X		10
01150001	CREMONESE SISTEMA UNICA	C001-C002-C003-C004-C005-C006-C007-C008-C009-C010-C012-C013-C014-C015-C016-C017-P001-P002-P004-P005-P006-P007-P008-P009-P010		104 mm	X		X	X	10
01151001	CREMONESE UNICA KEY	C001-C002-C003-C004-C005-C006-C007-C008-C009-C010-C012-C013-C014-C015-C016-C017-P001-P002-P004-P005-P006-P007-P008-P009-P010		104 mm	X		X	X	10
011691	CREMONESE UNICA MANICO DISASSATO CW2	-	Destra	104 mm	X		X		5
011692	CREMONESE UNICA MANICO DISASSATO CW2	-	Sinistra	104 mm	X		X		5
01230	CREMONESE UNICA RIBAS-SATA	C001-C002-C003-C004-C005-C006-C007-C008-C009-C010-C012-C013-C014-C015-C016-C017-P001-P002-P004-P005-P006-P007-P008-P009-P010		104 mm	X		X	X	5