

# Dampseal:

High quality, long lasting dampseal to protect against draught and damp.

Schlegel have designed push-in and slide-in flashing used as a barrier to prevent moisture and currents of air damaging the reveal. It allows quick and easy installation by incorporating rigid extruded profiles for insertion into the standard timber kerf and aluminium t-slot typically used for seals. The application method prevents the potentially hazardous practice of holding flashing in place while stapling it to the product.

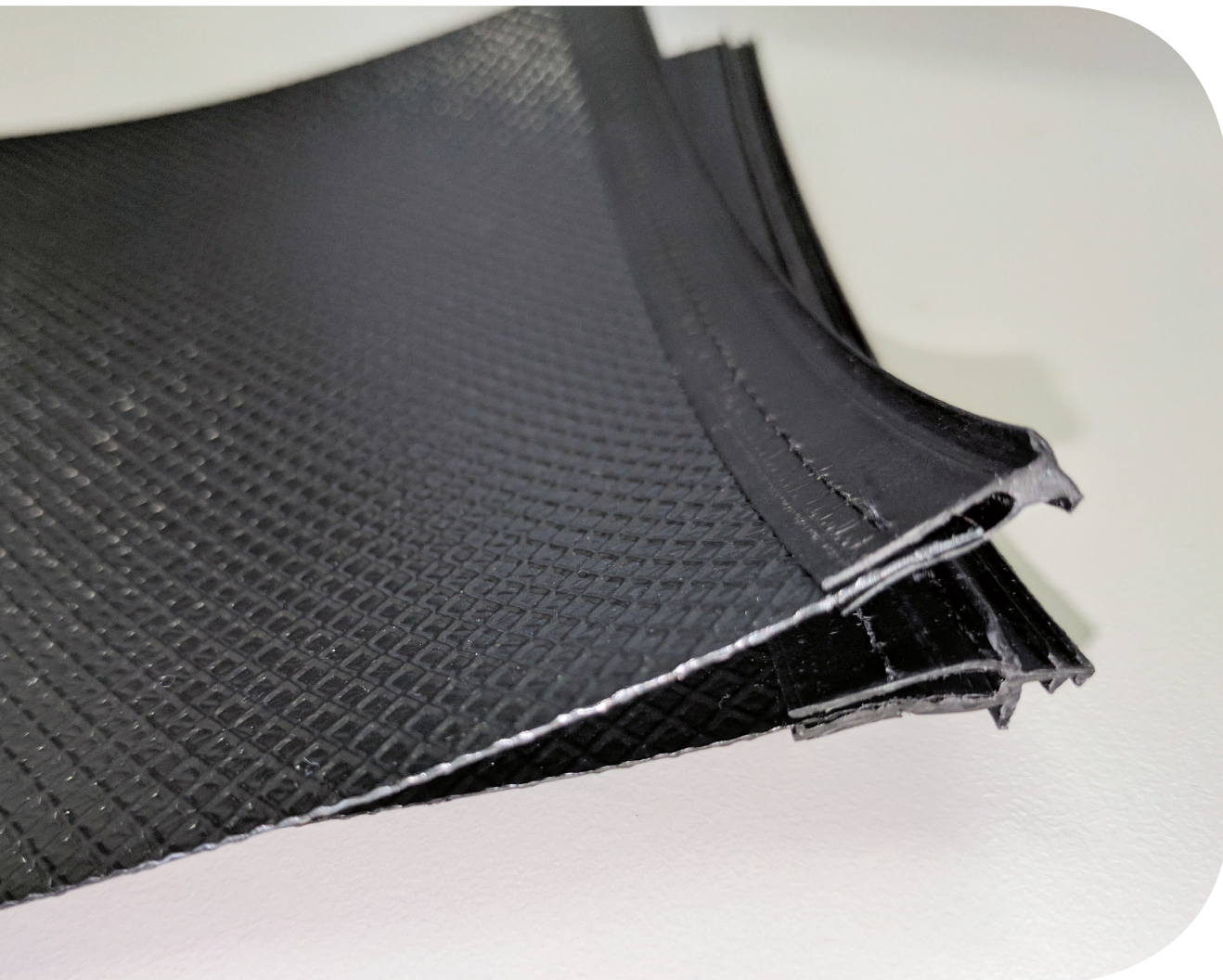

## Product Code

DAMPSEALSEW	T-slot for Alum	Black	30 metre roll
DAMPSEALSEW P7	Kerf for Timber	Black	30 metre roll

\* See technical drawings next page

Product Code  
 DAMPSEALSEW T-slot for Aluminium Black 30 metre roll

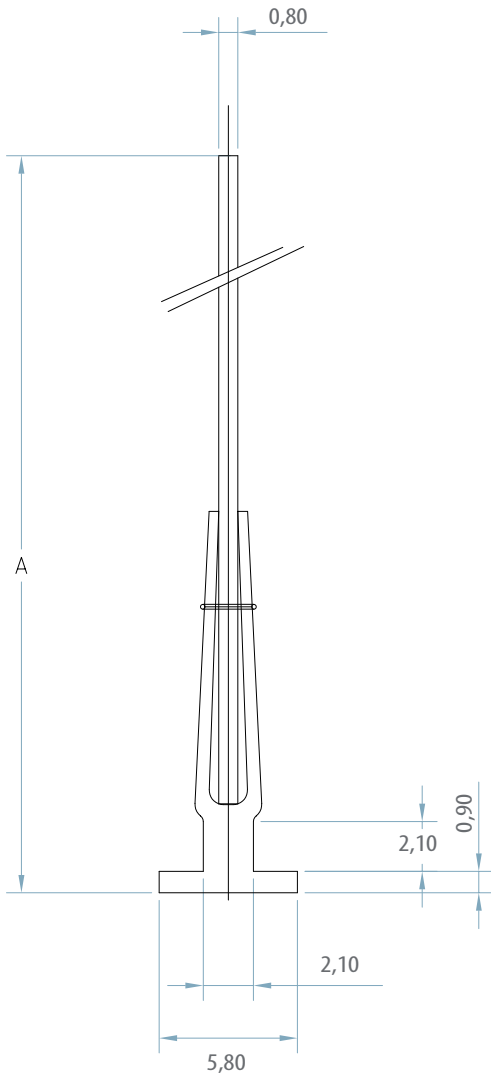

Product Code  
 DAMPSEALSEW P7 Kerf for Timber Black 30 metre roll

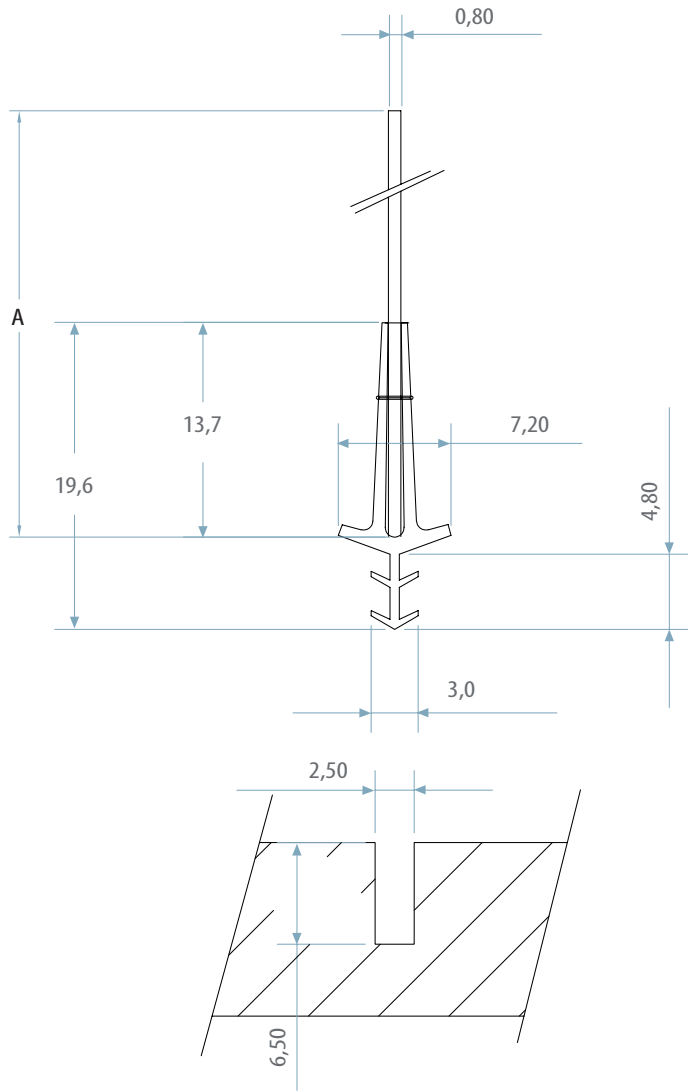

Recommended sawcut dimensions

**Head Office:**

44 Riverside Road Chipping Norton NSW 2170  
 Ph: +61 2 8707 2000 Fax: +61 2 8707 2070  
 Email: info.au@schlegel.com

**Victoria:**

44 Riverside Road Chipping Norton NSW 2170  
 Ph: +61 2 8707 2000 Fax: +61 2 8707 2070  
 Email: info.au@schlegel.com

**Queensland:**

44 Riverside Road Chipping Norton NSW 2170  
 Ph: +61 2 8707 2000 Fax: +61 2 8707 2070  
 Email: info.au@schlegel.com

**New Zealand:**

Burrett Business Park, 10d Burrett Ave  
 Penrose, Auckland 1061  
 Ph: +64 9 478 4001 Fax: +64 9 478 4002  
 Email: salesnz@schlegel.com

**Western Australia:**

3 / 45 Truganina Road Malaga WA 6090  
 Ph: +61 8 9224 9624 Fax: +61 8 9248 4855  
 Email: saleswa@schlegel.com

**ASEAN:**

1 Commonwealth Lane  
 #06-18, One Commonwealth  
 Singapore 149544  
 Ph: +65 6344 9288  
 Email: info.sg@schlegel.com

Care has been taken to ensure that the contents of this publication are accurate, but Schlegel and its subsidiary companies do not accept responsibility for errors or for information that is found to be misleading. Suggestions for, or description of, the end use or application of products or methods of working are for information only. All dimensions are in mm and are nominal. Schlegel reserve the right to change specification without prior notice.

Schlegel's names and logos and all related trademarks (including 'SCHLEGEL', 'SCHLEGEL Red Square Logo', 'Red Square Logo', trade names, and other intellectual property are the property of Schlegel Acquisition Holdings Limited trading as Schlegel International and cannot be used without its express prior written permission. All rights reserved.

© Schlegel Acquisition Holdings Limited trading as Schlegel International 2017.