

EXTRUDED SEALS: FOR TIMBER APPLICATIONS

LF 1105 (23010)

TECHNICAL SPECIFICATION

A Groove width: 1,5 mm minimum to 2,2 mm maximum

B Minimum groove depth: 11,5 mm

PACKAGING

400 m x 2

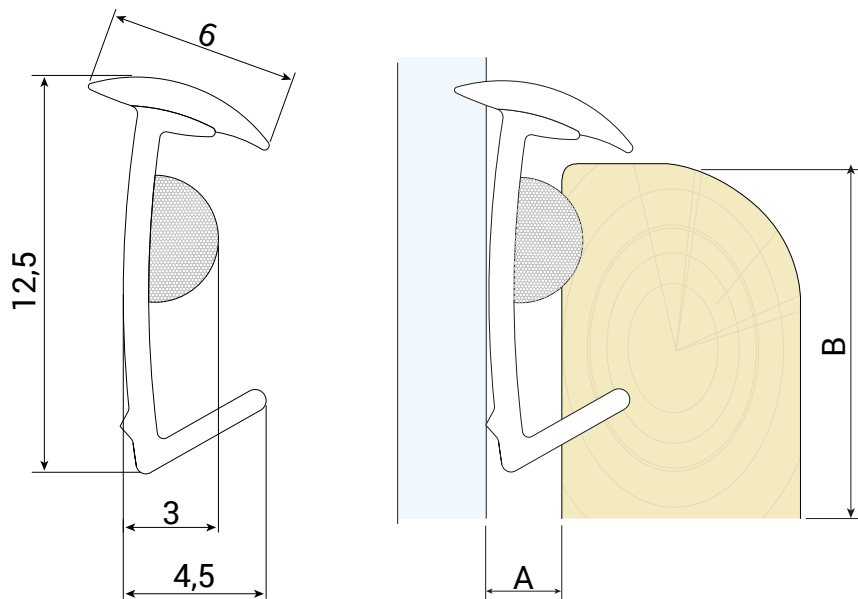

Coil direction

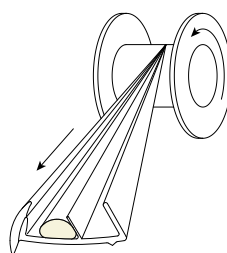

Colours (\approx RAL)

9005



Black

Other colours upon request